

Annual OR Special Warrant Articles - Spring 2024 Town Meeting							
#		Amt (if \$)	Sponsor	Form	Backup Info	On Warrant?	Select Board
(DRAFT)	Article	DRAFT		Received?	Received?	(SB 2/6/24)	Sponsor?
1	To give votes to the election of the public offices	n/a	n/a	n/a	n/a	Y	n/a
2	Reports of Town Officers and Committees	n/a	n/a	n/a	n/a	Y	n/a
3	School Stabilization Fund transfer	\$ 200,000	Town Manager	Y			
4	FY25 Town Operating Budget	TBD	FinCom	n/a		Y	n/a
5	Transfer Free Cash to reduce FY25 tax rate	TBD	Town Manager	Y	Y		
6	Instructions, Rules and Regulations for Board of Water Commissioners	n/a	???	Y		Y	
7	FY25 Water operating budget	TBD	BOWC	Y		Y	n/a
8	Establish Water Pension Liability Stabilization Fund	n/a	Town Manager	Y			
9	Appropriation from Septic Loan Revolving Fund	\$ 10,364	Town Manager	Y	Y	Y	
10	Transfer funds to Pension Liability Stabilization Fund	\$ 99,507	Town Manager	Y	Y		
11	Transfer funds to Other Post-Employment Benefits (OPEB) Stabilization Fund	\$ 21,586	Town Manager	Y	Y		
12	Appropriation of PEG Reserved Revenues under MGL c.44 s.53F3/4	TBD	CAC	Y		Y	n/a
13	Revolving funds (reauthorize and establish max amounts for FY25)	n/a	Town Manager	Y		Y	
14	CPA Article: Allocate and/or reserve Community Preservation Fund annual revenues	TBD	CPC	Y		Y	
15	CPA Article: Transfer CPA Housing Reserve funds to Affordable Housing Trust - <i>pending favorable review/recommendation by CPC</i>	TBD	AHT / SB	Y	Y		
16	CPA Article: Funding for Pickleball feasibility study - <i>pending favorable review/recommendation by CPC</i>	\$ 22,000	Select Board	Y	Y		
17	CPA Article: Sawmill Brook trails, design and permitting - <i>pending favorable review/recommendation by CPC</i>	TBD	Select Board	Y	Y		
18	CPA Article: Fund maintenance/clean-up of Town-owned cemeteries - <i>pending favorable review/recommendation by CPC</i>	\$ 4,000	Historical Comm	Y	Y		
19	Extend Sunset Dates for Previous Town Meeting Articles	n/a	Town Manager	Y	Y		
20	Authorize Select Board to enter Intermunicipal Agreement with City of Newburyport, re Middle Street Bridge, for term of up to 25 years	n/a	Town Manager				
21	CAPITAL (DPW-034): Appropriation and/or Debt Authorization for Middle Street Bridge	TBD	Town Manager				
22	CAPITAL (FD-003): Replace Fire Pumper Tanker	\$ 560,000	BOFE	Y	Y		
23	CAPITAL (DPW-043): Rocks Village Bridge warning signals	TBD	Town Manager	Y	Y		
24	CAPITAL (DPW-041): Annex flooring replacement	\$ 49,200	DPW/Facilities	Y			
25	CAPITAL (COA-002): Replace A/C Unit in Council on Aging / SAGE Center	\$ 38,000	DPW/Facilities	Y	Y		
26	CAPITAL (DPW-038): Replace Generator for Town Offices/Annex	\$ 90,000	DPW/Facilities	N	Y		
27	CAPITAL (PGE-002): Page School flooring repairs	\$ 50,000	Pentucket/DPW	Y	Y		
28	CAPITAL (PGE-005): Page School Interior Improvements/Repairs	\$ 75,000	Pentucket/DPW	N	Y		
29	CAPITAL (DPW-010): DPW Plow Truck	\$ 350,000	DPW/Highway	Y	Y		
30	CAPITAL (DPW-004): Zero-Turn Mower for DPW	\$ 33,500	DPW/Highway	Y	Y		
31	CAPITAL (DPW-042): Add'l Accessories for DPW Trackless Vehicle	\$ 41,540	DPW/Highway	Y	Y		
32	CAPITAL (DPW-037): Supplemental funding for telecom upgrades at Town Offices, Public Safety Complex and Library	TBD	Town Manager	Y	Y		
33	CAPITAL (DPW-035): Town Offices Electronic Keying System	\$ 35,000	DPW/Facilities	Y	Y		

Annual OR Special Warrant Articles - Spring 2024 Town Meeting						
# (DRAFT) Article	Amt (if \$) DRAFT	Sponsor	Form Received?	Backup Info Received?	On Warrant? (SB 2/6/24)	Select Board Sponsor?
34	CAPITAL (PD-003): Roof replacement, Public Safety Complex	\$ 120,000	DPW/Facilities	Y	Y	
35	CAPITAL (DPW-024): Public Safety Complex, interior/exterior improvements	\$ 75,000	DPW/Facilities	Y	Y	
36	Funds for required testing at Steele Landfill	\$ 22,915	BOH	N	Y	
37	Replace Water Pump at Wellfield	\$ 19,000	BOWC	N	Y	
38	Engineering funds for Coffin Street culvert replacement (CAPITAL DPW-040)?	\$ 48,213	Town Manager	Y	Y	
39	Page School standpipe installation (engineering/design) (CAPITAL PGE-012)?	\$ 30,000	Pentucket/DPW	N	Y	
40	Page School: study design/cost to bring elevator into ADA compliance (CAPITAL PGE-009)?	TBD	Pentucket/DPW	N	Y	
41	Page School: engineering/design re internal site circulation, lighting (CAPITAL PGE-020)?	TBD	Town Manager	N	Y	
42	Funds for removal of dead ash trees along public rights-of-way	\$ 50,000	DPW/Highway	Y		
43	Funds to replace retaining wall at 1910 Building (Town Offices)	\$ 12,000	DPW/Facilities	Y		
44	Unbudgeted Personnel Costs, FY24-25	TBD	Town Manager	Y		
45	Snow & Ice deficit (amount TBD)	TBD	DPW/Highway	Y		
46	Unpaid FY24 Bills	TBD	Town Manager	Y	Y	
47	Proposed Zoning Amendment: Adopt MBTA Communities overlay district	n/a	Planning Board	Y	Y	
48	Proposed adoption of Wetlands Bylaw	n/a	ConCom	Y	Y	
49	Proposed amendments to Capital Improvements Committee Bylaw	n/a	Town Manager	Y	Y	
50	Proposed amendments to General Harbor Regulations Bylaw	n/a	???	N		
51	Proposed amendments to Hunting Bylaw	n/a	???	N		
52	Proposed amendments to Animal Bylaw	n/a	???	N		
53	Proposed amendment to allow Town Moderator to determine 2/3 vote	n/a	Town Clerk	Y		
54	Proposed amendments to Zoning Bylaws: Definitions	n/a	Bldg. Inspector	Y	Y	
55	Establish Police Detail Reserve Fund per MGL Ch. 44 Sec. 53C	n/a	Bldg. Inspector	Y		
56	Dissolve Opioid Settlement Stabilization Account	n/a	Town Acct.	Y	Y	
57	Proposed establishment of Capital Stabilization Fund	n/a	Town Manager	Y		
58	Acceptance of MGL 59 Sec. 5N re Property Tax Relief for Veterans' who volunteer	no appropriation	Town Clerk	N	Y	
59	Citizen Petition: Mullen and Soldiers & Sailors properties, 40R study/zoning and MBTA Communities zoning	\$ 100,000	Citizen Petition	n/a	Y	Y n/a
60	Citizen Petition: File Home Rule Petition for Commonwealth to reduce voting age to 16	n/a	Citizen Petition	n/a	Y	Y n/a

Notes:

Numbering does **not** correspond to order or numbering that will appear on Town Meeting warrants.

Cells shaded in orange indicate areas where Town Manager will provide add'l information prior to warrant closing.

Cells shaded in green indicate that the materials have been added to PDF info packet.

Cells shaded in blue are recommended/requested for STM, not ATM.

ARTICLE REQUEST FORM

ARTICLE: To see if the Town will vote to appropriate the sum of \$200,000 from the special purpose municipal stabilization fund established pursuant to Massachusetts General Laws c. 40 §5B in order to offset West Newbury's FY25 capital assessment from the Pentucket Regional School District for the Middle/High School building project.

AMOUNT REQUESTED: \$200,000.00

CONTACT PERSON: Angus Jennings, Town Manager

PHONE NUMBER: 978-363-1100 ext. 115

Why should the Town make this purchase? What needs will be met? Who will benefit?

The purpose of the Special Purpose Education Stabilization Fund is to offset the debt resulting from the new PRSD Middle/High School to minimize the impact on tax rates. Note: proposed amount is a placeholder only, and will rely on review/recommendation from Select Board as proposed article sponsor.

NOTE: If the Whittier School Committee budget proposes significant capital expenditures in FY25, and/or forecasts major capital expenses in FY26+, this information will need to be taken into account in determining whether and in what amount to propose to transfer from School Stabilization. Depending on the scale of proposed/anticipated capital costs at Whittier Tech, it may warrant considering a transfer of funds into School Stabilization in FY25.

What factors affect the timing of this purchase?

If approved by voters at Town Meeting, the amount authorized from School Stabilization would be reduced from the proposed FY25 operating budget for Pentucket capital assessments.

When should this Article be sunsetted - how long will the project take?

FY25

What ancillary costs do you anticipate? (Maintenance, Insurance, Training, etc.)

none

Does this Article involve improvement, preservation or creation of tangible Town-owned assets and projects which 1) have useful life of at least five years; 2) cost over \$20,000 and or 3) for which the Town is authorized to borrow funds? If so, please confirm that this item is on the Capital Improvements Committee Schedule for future capital investments.

n/a

Please attach additional pages or other supporting documentation.

ARTICLE REQUEST FORM

ARTICLE: To see if the Town will transfer Free Cash to offset the FY25 tax rate

AMOUNT REQUESTED: TBD

CONTACT PERSON: Town Manager

PHONE NUMBER: 978-363-1100 x115

Why should the Town make this purchase? What needs will be met? Who will benefit?

Over the past several years, other than in the current FY24, the Town has approved a funding transfer at the Fall STM in order to offset the year's tax rate. (In 6 of those years, the source was Free Cash; in FY21, the Town instead approved an allocation of Overlay Surplus). Over the course of the FY25 budgeting process, the Finance Department will work to prepare an estimate of the FY25 tax rate, taking into account the proposed Town budget (once the SB/FinCom review process is complete), projections of FY25 Assessed Values, projections of potential FY25 New Growth, and projections of FY25 non-property tax revenues (i.e. excise, fees, etc.). It is recommended that the Select Board include a placeholder article on the ATM warrant in order to preserve the Board's option - if it wishes to do so - to transfer Free Cash in order to offset next year's tax rate.

What factors affect the timing of this purchase?

If an article is not taken up at the Annual Town Meeting, and the Board wishes to see such transfer take place, a Fall STM would be needed in order to affect the FY25 tax rate.

When should this Article be sunsetted - how long will the project take?

FY25

What ancillary costs do you anticipate? (Maintenance, Insurance, Training, etc.)

N/A

Does this Article involve improvement, preservation or creation of tangible Town-owned assets and projects which 1) have useful life of at least five years; 2) cost over \$20,000 and or 3) for which the Town is authorized to borrow funds? If so, please confirm that this item is on the Capital Improvements Committee Schedule for future capital investments.

No

Please attach additional pages or other supporting documentation.



Town of West Newbury

381 Main Street

West Newbury, Massachusetts 01985

Angus Jennings, Town Manager

978-363-1100, Ext. 111 Fax 978-363-1826

townmanager@wnewbury.org

TO: Select Board
FROM: Angus Jennings, Town Manager
DATE: September 25, 2023
RE: Estimated FY24 tax rate and potential Free Cash transfer

Taking into account preliminary estimates of FY24 Assessed Values, New Growth and projected non-tax revenues, the approved FY24 operating budget and all approved (spring 2023) and proposed (fall 2023) Town Meeting articles would result in an estimated FY24 tax rate of \$10.95, a decrease from the current year tax rate of \$11.03.¹

Taking into account an estimated average increase in assessed values of 5.0% from FY23 to FY24, this would result in an estimated property tax increase of \$352.21 (4.24%) for a property valued at \$753,400 (the 50th percentile) in FY23. (Estimated tax bill changes, for properties at different values, are attached).

In recent years, Town Meeting voters have appropriated Free Cash at the fall STM to reduce the tax rate, with an average transfer of \$221,186 from FY17-23.²

If the Board were to propose – and Town Meeting were to approve – a fall STM Free Cash transfer of \$250,000, this would result in an estimated annual tax increase, for a home valued at \$753,400 in FY23, of \$225.64 (2.72%).

At Wednesday night's meeting, the Board can review various scenarios to inform your consideration of whether to propose a STM transfer from Free Cash, and if so in what amount, to arrive at an updated estimated FY24 tax rate.

It should be understood that all estimates are preliminary, and will change as new information becomes available, including regarding New Growth, Assessed Values, and non-tax revenues.

cc: *Finance Committee*
Town Accountant
Chief Assessor

¹ This estimate was prepared using the MassDOR Tax Rate Recap Model and rests (as these estimates always do) on reasonable projections of unknowable inputs such as New Growth, Assessed Values and non-tax revenues. (Methodology for both projections are consistent with prior years' methodologies).

² This includes the Fall 2020 transfer of Overlay Surplus balance, in the amount of \$220,000, in order to reduce that year's (FY21) tax rate. If this transfer is omitted, the average amount of Free Cash transfer over this period of time would be \$189,757.

SINGLE-FAMILY PROPERTY TAX BILL COMPARISON TOOL									
PROPERTY DECILES (BASED ON FY23 VALUES)	2023 PROPERTY VALUE	FY 2023 CERTIFIED TAX RATE	EST FY 2023 TAX BILL	2024 ESTIMATED PROPERTY VALUE	FY 2024 ESTIMATED TAX RATE	EST FY 2024 TAX BILL	EST \$ INCREASE IN BILL	EST % INCREASE IN BILL	
10TH PERCENTILE	543,200	11.03	5,991.50	570,360	10.95	6,245.44	253.95	4.24%	
20TH PERCENTILE	597,100	11.03	6,586.01	626,955	10.95	6,865.16	279.14	4.24%	
30TH PERCENTILE	646,300	11.03	7,128.69	678,615	10.95	7,430.83	302.15	4.24%	
40TH PERCENTILE	698,400	11.03	7,703.35	733,320	10.95	8,029.85	326.50	4.24%	
50TH PERCENTILE	753,400	11.03	8,310.00	791,070	10.95	8,662.22	352.21	4.24%	
60TH PERCENTILE	810,000	11.03	8,934.30	850,500	10.95	9,312.98	378.68	4.24%	
70TH PERCENTILE	888,900	11.03	9,804.57	933,345	10.95	10,220.13	415.56	4.24%	
80TH PERCENTILE	984,400	11.03	10,857.93	1,033,620	10.95	11,318.14	460.21	4.24%	
90TH PERCENTILE	1,144,900	11.03	12,628.25	1,202,145	10.95	13,163.49	535.24	4.24%	
EST. TYPICAL INCREASE:							4.24%		
\$500k house	500,000	11.03	5,515.00	525,000	10.95	5,748.75	233.75	4.24%	

Source: Angus Jennings, Town Manager, 9/25/23

SINGLE-FAMILY PROPERTY TAX BILL COMPARISON TOOL - WITH FREE CASH TRANSFER IN AMOUNT OF \$250,000								
PROPERTY DECILES (BASED ON FY23 VALUES)	2023 PROPERTY VALUE	FY 2023 CERTIFIED TAX RATE	EST FY 2023 TAX BILL	2024 ESTIMATED PROPERTY VALUE	FY 2024 ESTIMATED TAX RATE	EST FY 2024 TAX BILL	EST \$ INCREASE IN BILL	EST % INCREASE IN BILL
10TH PERCENTILE	543,200	11.03	5,991.50	570,360	10.79	6,154.18	162.69	2.72%
20TH PERCENTILE	597,100	11.03	6,586.01	626,955	10.79	6,764.84	178.83	2.72%
30TH PERCENTILE	646,300	11.03	7,128.69	678,615	10.79	7,322.26	193.57	2.72%
40TH PERCENTILE	698,400	11.03	7,703.35	733,320	10.79	7,912.52	209.17	2.72%
50TH PERCENTILE	753,400	11.03	8,310.00	791,070	10.79	8,535.65	225.64	2.72%
60TH PERCENTILE	810,000	11.03	8,934.30	850,500	10.79	9,176.90	242.60	2.72%
70TH PERCENTILE	888,900	11.03	9,804.57	933,345	10.79	10,070.79	266.23	2.72%
80TH PERCENTILE	984,400	11.03	10,857.93	1,033,620	10.79	11,152.76	294.83	2.72%
90TH PERCENTILE	1,144,900	11.03	12,628.25	1,202,145	10.79	12,971.14	342.90	2.72%
EST. TYPICAL INCREASE:							2.72%	
\$500k house	500,000	11.03	5,515.00	525,000	10.79	5,664.75	149.75	2.72%

Source: Angus Jennings, Town Manager, 9/25/23



Town of West Newbury

381 Main Street

West Newbury, Massachusetts 01985

Angus Jennings, Town Manager

978-363-1100, Ext. 111 Fax 978-363-1826

townmanager@wnewbury.org

TO: Select Board
 FROM: Angus Jennings, Town Manager
 DATE: September 30, 2023
 RE: Recommendation to retain Tax Relief article on STM Warrant

This is to document my and the Town Accountant's recommendation regarding the potential transfer of Free Cash to offset the FY24 tax rate. In conversations with individual Board members since the meeting on Wednesday, I have become aware that my recommendation regarding the draft article may not have come through clearly at the meeting; my memo of Sept. 25 ("RE: Estimated FY24 tax rate and potential Free Cash transfer") provided context but not a clear recommendation.

This memo is to clarify that the Finance Department and my office recommend inclusion of an article on the Fall STM warrant to transfer free cash to offset the FY24 tax rate.

The following includes new information, not available at the Sept. 27 meeting, and also summarizes the basis of our recommendation to retain an article on the STM warrant:

- The operating budget increased 3.2% in FY24 (relative to FY23). Ideally, the average tax bill would not exceed by a greater percentage than the increase in operating budget.
- If all draft STM articles are combined, the aggregate cost to Free Cash will be approx. \$240,844.

(This number may decrease or increase somewhat depending on the final form of warrant, incl. resolving a couple of draft amounts re water study/testing and Police equipment). This amount is considerably lower than I had verbally estimated at Wednesday's meeting; I had been looking quickly at a working file Excel workbook, and this workbook has since been proofed/updated.

- Although not codified in written policy, Free Cash transfers have been a consistent practice dating back to FY2017, in an average annual amount of \$221k. (See Table to right). We believe that taxpayers should be given the opportunity to decide whether to continue this practice or not.

Free Cash Trends, FY16-FY23

Fiscal Year	Year-End Certified Free Cash ¹	Free Cash transfer to reduce Tax Rate ²
FY24	TBD	\$ -
FY23	\$ 2,386,317	\$ 250,000
FY22	\$ 2,128,806	\$ 200,000
FY21	\$ 1,749,980	\$ -
FY20	\$ 1,954,878	\$ 400,000
FY19	\$ 2,102,586	\$ 220,000
FY18	\$ 1,718,985	\$ 114,000
FY17	\$ 1,824,005	\$ 144,300
FY16	\$ 1,892,315	\$ -

Avg (FY17-23)	\$ 189,757
---------------	------------

¹ Source: MA DOR Form B-1, FY15-FY23

² Source: MA DOR Tax Rate Recaps, Item IIIId, FY16-FY23

* Note: In FY21 the Town did allocate \$220,000 of Overlay Surplus in order to reduce the FY21 Tax Rate. If that amount were to be included in the table above, the FY17-23 average would be \$221,186.

Source: Angus Jennings, Town Manager

- As we have discussed with the Board and Finance Committee on many occasions, the Finance Department’s annual projections of non-tax revenues – a key ingredient in the Tax Rate Recap – include significant conservatism. This is mandated by MassDOR policy and guidelines. Over the past four fiscal years, actual non-tax revenues have exceeded projected revenues by an average of \$194k/year. (See attached table, Local Receipts FY20-23). A similar overage is reasonable to project for FY24.
- Due to a combination of conservative budgeting and underspending, the operating budget has turned back an average aggregate amount of \$498k over the past four fiscal years. (See attached table, Omnibus Budget FY20-23). Although trending downward, the Town can reasonably project substantial turnbacks for FY24.
- The following trend lines – prepared and circulated to the Board, Finance Committee and Capital Improvements Committee, among others, during the FY24 budget cycle – show healthy and improving balances in Free Cash and Stabilization accounts:

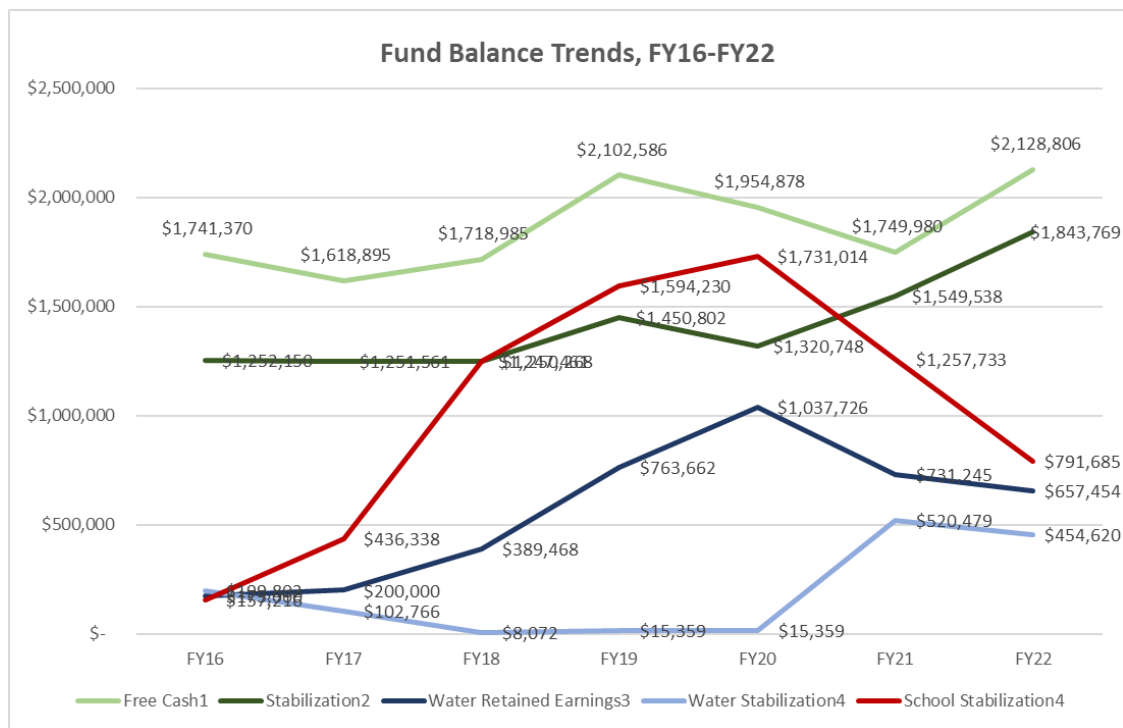

Although not yet updated to reflect FY23 year-end closeout (which will coincide with closeout of FY23 Audit), the FY23 Free Cash certification illustrates one area of known, further improvement since the data shown here. Notwithstanding that there are still – as always – some “moving parts” with regard to future capital project costs (incl. the potential for significant changes to Town capital liabilities, depending on the outcome of future policy decisions regarding, especially, water and school), the Town is in excellent financial condition.

Through Town Meeting, taxpayers are entitled and required to approve, amend and approve, or may reject, the Town budget and sections thereof. The impact of this decision on taxpayers’ wallets – measured purely in dollars – is analogous to a budgetary line item of comparable amount to prior years’ average transfers. Just as taxpayers approve the allocation of the budget, it seems appropriate that they would also have a role in such a consequential decision regarding the use of Free Cash.

cc: Town Accountant, Finance Committee

Local Receipts: FY20-FY23								
	<u>6/30/2020</u>		<u>6/30/2021</u>		<u>6/30/2022</u>		<u>6/30/2023</u>	
	<u>Estimated</u>	<u>Actual</u>	<u>Estimated</u>	<u>Actual</u>	<u>Estimated</u>	<u>Actual</u>	<u>Estimated</u>	<u>Actual</u>
Motor Vehicle	\$ 810,000	\$ 784,124	\$ 743,580	\$ 814,348	\$ 775,000	\$ 858,791	\$ 870,000	\$ 839,490
Other Excise	\$ 1,600	\$ 1,750	\$ 1,600	\$ 1,617	\$ 1,600	\$ 2,076	\$ 1,800	\$ 881
Pen & Int Taxes & Excise	\$ 39,185	\$ 55,885	\$ 45,000	\$ 59,004	\$ 45,000	\$ 70,988	\$ 55,000	\$ 43,730
PILOT	\$ 14,000	\$ 19,494	\$ 15,000	\$ 53,368	\$ 42,443	\$ 89,829	\$ 20,000	\$ 52,497
Rentals	\$ 145,000	\$ 122,144	\$ 122,309	\$ 138,273	\$ 160,625	\$ 161,014	\$ 161,014	\$ 168,185
Other Dept Rev	\$ 17,000	\$ 17,585	\$ 17,000	\$ 24,977	\$ 20,000	\$ 25,231	\$ 27,000	\$ 18,210
Lic & Permits	\$ 220,000	\$ 267,024	\$ 249,859	\$ 227,541	\$ 200,000	\$ 192,043	\$ 197,162	\$ 257,161
Fines & Forfeits	\$ 15,000	\$ 12,096	\$ 12,000	\$ 9,070	\$ 10,000	\$ 13,604	\$ 12,000	\$ 9,738
Invest Income	\$ 70,000	\$ 60,478	\$ 34,430	\$ 21,373	\$ 20,000	\$ 7,765	\$ 14,000	\$ 112,495
Misc Recurring	\$ 26,000	\$ 26,000	\$ 30,000	\$ 30,000	\$ 30,750	\$ 30,750	\$ 31,518	\$ 38,606
Misc Non-recurring		\$ 1,072		\$ 72,948		\$ 48,717		\$ 53,154
Total	\$ 1,357,785	\$ 1,367,652	\$ 1,270,778	\$ 1,452,519	\$ 1,305,418	\$ 1,500,809	\$ 1,389,494	\$ 1,594,147
	\$9,867		\$181,741		\$195,390		\$204,654	

\$193,928
Average

Omnibus Budget: FY20-FY23								
	<u>6/30/2020</u>		<u>6/30/2021</u>		<u>6/30/2022</u>		<u>6/30/2023</u>	
	<u>Budget</u>	<u>Actual</u>	<u>Budget</u>	<u>Actual</u>	<u>Budget</u>	<u>Actual</u>	<u>Budget</u>	<u>Actual</u>
Total	\$ 16,587,263	\$ 16,012,637	\$ 17,318,830	\$ 16,736,939	\$ 18,262,839	\$ 17,805,088	\$ 18,276,431	\$ 17,822,917
	\$574,626		\$581,891		\$457,750		\$453,514	

\$497,718
Average

Source: Jennifer Walsh, Town Accountant

ARTICLE REQUEST FORM

ARTICLE: In accordance with the provisions of Chapter 38 of the Acts of 1936, to see what instructions, rules, and regulations the Town may wish to impose on the Board of Water Commissioners, or take any other action relative thereto.

AMOUNT REQUESTED: N/A

CONTACT PERSON:

PHONE NUMBER:

Why should the Town make this purchase? What needs will be met? Who will benefit?

What factors affect the timing of this purchase?

When should this Article be sunsetted - how long will the project take?

What ancillary costs do you anticipate? (Maintenance, Insurance, Training, etc.)

Does this Article involve improvement, preservation or creation of tangible Town-owned assets and projects which 1) have useful life of at least five years; 2) cost over \$20,000 and or 3) for which the Town is authorized to borrow funds? If so, please confirm that this item is on the Capital Improvements Committee Schedule for future capital investments.

Please attach additional pages or other supporting documentation.

ARTICLE REQUEST FORM

ARTICLE: To see if the Town will vote to appropriate, in anticipation of Water Department revenue, the sum of \$0,000,000.00 of which \$000,000.00 for Salaries & Wages, \$00,000.00 for Insurances, \$000,000.00 Expenses, \$000,000.00 for Debt Service, \$00,000.00 for Extraordinary and Unforeseen, and \$00,000.00 for Indirect Cost.

AMOUNT REQUESTED: \$0,000,000.00

CONTACT PERSON: Mark Marlowe

PHONE NUMBER: 978-363-1100 x128

Why should the Town make this purchase? What needs will be met? Who will benefit?

This will approve the Water Department operating budget for Fiscal Year 2025

What factors affect the timing of this purchase?

N/A

When should this Article be sunsetted - how long will the project take?

FY25

What ancillary costs do you anticipate? (Maintenance, Insurance, Training, etc.)

N/A

Does this Article involve improvement, preservation or creation of tangible Town-owned assets and projects which 1) have useful life of at least five years; 2) cost over \$20,000 and or 3) for which the Town is authorized to borrow funds? If so, please confirm that this item is on the Capital Improvements Committee Schedule for future capital investments.

Please attach additional pages or other supporting documentation.

ARTICLE REQUEST FORM

ARTICLE: To see if the town will vote to accept the provisions of Massachusetts General Laws, Chapter 40 Section 5B to create a special purpose Municipal Stabilization Fund to be known as the Water Pension Liability Stabilization Fund in order to fund future pension liabilities.

AMOUNT REQUESTED: N/A

CONTACT PERSON: Angus Jennings, Town Manager

PHONE NUMBER: 978-363-1100 x115

Why should the Town make this purchase? What needs will be met? Who will benefit?

With this Article, the Town would accept state Stabilization Fund provisions for the purpose of creating a new and distinct Water Pension Stabilization Fund intended to set aside money to pay for the Water Department's unfunded pension obligations. Establishing a Water Pension Stabilization Fund will allow the Water Department to plan and save ahead to meet its obligation by putting away funds when Water finances so permit, avoiding the need for abrupt rate increases.

What factors affect the timing of this purchase?

The Town established a Pension Liability Stabilization Fund by vote of Town Meeting in April, 2016. Since that time, Town Meeting has routinely appropriated funds (generally, Free Cash) into the fund in order to fully fund its long-term pension obligations. The funding into this account has been entirely from General Fund revenues, not the Water Enterprise Fund. It is recommended that a separate such fund be established for Water Department retirees, to be funded (by votes to be proposed at future Town Meetings) by Water Enterprise revenues. This is similar to the existing Town and Water separate OPEB Stabilization Funds.

When should this Article be sunsetted - how long will the project take?

N/A

What ancillary costs do you anticipate? (Maintenance, Insurance, Training, etc.)

N/A

Does this Article involve improvement, preservation or creation of tangible Town-owned assets and projects which 1) have useful life of at least five years; 2) cost over \$20,000 and or 3) for which the Town is authorized to borrow funds? If so, please confirm that this item is on the Capital Improvements Committee Schedule for future capital investments.

No

Please attach additional pages or other supporting documentation.

ARTICLE REQUEST FORM

ARTICLE: To see if the Town will vote to transfer the sum of \$10,364 from the Septic Loan Revolving Account for the repayment of debt service.

AMOUNT REQUESTED: \$10,364.00

CONTACT PERSON: Angus Jennings, Town Manager

PHONE NUMBER: 978-363-1100 x115

Why should the Town make this purchase? What needs will be met? Who will benefit?

In 2001 the Town enrolled in a twenty-year state-financed program to loan residents money to help them rebuild septic systems that do not conform to Title V. This State program offers 0% loans to communities, which in turn provide low-interest betterment loans to eligible homeowners with failed septic systems through the local Board of Health. The Town loaned money at a rate of 3% (to cover the cost of administration). The homeowners repay the loan money to the Town, which in turn reimburses the State. Neither the Town nor the State profits from this transaction. The Town has been making these payments since 2001 with the amount based on the number of borrowers. This program is no longer open to new participants. This will be the final payment for this program.

What factors affect the timing of this purchase?

For FY25 the loan amount due is \$10,364.

When should this Article be sunsetted - how long will the project take?

FY25

What ancillary costs do you anticipate? (Maintenance, Insurance, Training, etc.)

None

Does this Article involve improvement, preservation or creation of tangible Town-owned assets and projects which 1) have useful life of at least five years; 2) cost over \$20,000 and or 3) for which the Town is authorized to borrow funds? If so, please confirm that this item is on the Capital Improvements Committee Schedule for future capital investments.

No

Please attach additional pages or other supporting documentation.

Town of West Newbury, Massachusetts

\$196,900 MA Water Pollution Abatement Loan

Dated : October 31, 2005

Pool 11 Title V, series 7 00-1001-1

Debt Service Schedule

Date	Principal	Coupon	Total P+I	Fiscal Total
10/31/2005	-	-	-	-
07/15/2006	10,363.00	-	10,363.00	-
06/30/2007	-	-	-	10,363.00
07/15/2007	10,363.00	-	10,363.00	-
06/30/2008	-	-	-	10,363.00
07/15/2008	10,363.00	-	10,363.00	-
06/30/2009	-	-	-	10,363.00
07/15/2009	10,363.00	-	10,363.00	-
06/30/2010	-	-	-	10,363.00
07/15/2010	10,363.00	-	10,363.00	-
06/30/2011	-	-	-	10,363.00
07/15/2011	10,363.00	-	10,363.00	-
06/30/2012	-	-	-	10,363.00
07/15/2012	10,363.00	-	10,363.00	-
06/30/2013	-	-	-	10,363.00
07/15/2013	10,363.00	-	10,363.00	-
06/30/2014	-	-	-	10,363.00
07/15/2014	10,363.00	-	10,363.00	-
06/30/2015	-	-	-	10,363.00
07/15/2015	10,363.00	-	10,363.00	-
06/30/2016	-	-	-	10,363.00
07/15/2016	10,363.00	-	10,363.00	-
06/30/2017	-	-	-	10,363.00
07/15/2017	10,363.00	-	10,363.00	-
06/30/2018	-	-	-	10,363.00
07/15/2018	10,363.00	-	10,363.00	-
06/30/2019	-	-	-	10,363.00
07/15/2019	10,363.00	-	10,363.00	-
06/30/2020	-	-	-	10,363.00
07/15/2020	10,363.00	-	10,363.00	-
06/30/2021	-	-	-	10,363.00
07/15/2021	10,363.00	-	10,363.00	-
06/30/2022	-	-	-	10,363.00
07/15/2022	10,364.00	-	10,364.00	-
06/30/2023	-	-	-	10,364.00
07/15/2023	10,364.00	-	10,364.00	-
06/30/2024	-	-	-	10,364.00
07/15/2024	10,364.00	-	10,364.00	-
06/30/2025	-	-	-	10,364.00
Total	\$196,900.00	-	\$196,900.00	-

Yield Statistics

Bond Year Dollars.....	\$1,911.59
Average Life.....	9.708 Years
Average Coupon.....	-
Net Interest Cost (NIC).....	-
True Interest Cost (TIC).....	-1.20E-11
Bond Yield for Arbitrage Purposes.....	-1.20E-11
All Inclusive Cost (AIC).....	-1.20E-11

IRS Form 8038

Net Interest Cost.....	-
Weighted Average Maturity.....	9.708 Years

ARTICLE REQUEST FORM

ARTICLE: To see if the Town will vote to raise and appropriate and/or transfer from available funds the sum of \$99,507 for the Pension Liability stabilization fund, or take any other action related thereto.

AMOUNT REQUESTED: \$99,507.00

CONTACT PERSON: Angus Jennings, Town Manager

PHONE NUMBER: 978-363-1100 x111

Why should the Town make this purchase? What needs will be met? Who will benefit?

This Article proposes transfer funds from Free Cash into the Pension Liability Stabilization Fund. This fund is intended to set aside money to pay for the Town's unfunded pension obligations. The Town's Financial Reserves policy recommends annual appropriation of 10% of the following year's Pension Assessment toward this Stabilization Fund, and the Town has made these recommended appropriations annually for the past several years.

What factors affect the timing of this purchase?

This will allow the Town to plan and save ahead to meet this obligation when the Town finances permit, thereby avoiding the need for abrupt tax increases.

When should this Article be sunsetted - how long will the project take?

FY25

What ancillary costs do you anticipate? (Maintenance, Insurance, Training, etc.)

None

Does this Article involve improvement, preservation or creation of tangible Town-owned assets and projects which 1) have useful life of at least five years; 2) cost over \$20,000 and or 3) for which the Town is authorized to borrow funds? If so, please confirm that this item is on the Capital Improvements Committee Schedule for future capital investments.

No

Please attach additional pages or other supporting documentation.

PERAC

COMMONWEALTH OF MASSACHUSETTS | PUBLIC EMPLOYEE RETIREMENT ADMINISTRATION COMMISSION

PHILIP Y. BROWN, ESQ., *Chair*

JOHN W. PARSONS, ESQ., *Executive Director*

Auditor DIANA DIZOGLIO | KATHLEEN M. FALLON | KATE FITZPATRICK | JAMES J. GUIDO | RICHARD MACKINNON, JR. | JENNIFER F. SULLIVAN, ESQ.

DEC 12 '23 PM 1:40

MEMORANDUM

TO: Essex Regional Retirement Board
FROM: John W. Parsons, Esq., Executive Director
RE: Appropriation for Fiscal Year 2025
DATE: December 7, 2023

Required Fiscal Year 2025 Appropriation: **\$50,487,468**

This Commission is hereby furnishing you with the amount to be appropriated for your retirement system for Fiscal Year 2025 which commences July 1, 2024.

Attached please find the portion of the Fiscal Year 2025 appropriation to be paid by each of the governmental units within your system.

The amount above assumes appropriations will be made July 1. Some units make the appropriation in equal installments on July 1 and January 1. The allocation shows the figures for each unit on both bases. The amount above includes the additional special appropriation for the Manchester-Essex Regional School District and the Rowley Housing Authority. We have included these additional amounts in the Additional Appropriation for CRAB column on Pages 2 and 3.

The current schedule is due to be updated by Fiscal Year 2025.

If you have any questions, please contact PERAC's Actuary, John Boorack, at (617) 666-4446 Extension 935.

JWP/jfb
Attachment

p:\actuarial\approp\approp25\fy25 for web\essex county approp 25.docx



Essex Regional Retirement System FY25 Appropriation by Governmental Unit

Aggregate amount for appropriation for the Pension Fund: \$50,431,846
 Aggregate amount for appropriation for the Pension Reserve Fund: \$0
 Aggregate additional appropriation for the E.R.I.: \$55,622

<u>UNIT</u>	<u>PEN.FND. APP %</u>	<u>PENSION FUND APPROP.</u>	<u>PENSION RES. FUND APPROP.</u>	<u>ADD'L. APP. FOR E.R.I.</u>	<u>ADD'L. APP. FOR CRAB</u>	<u>TOTAL PAID JULY 1</u>	<u>APPROP SEMI-ANNUAL</u>
Agricultural School	0.00%	0	0			0	0
Retirement Board	0.00%	0	0			0	0
Town of Boxford	3.30%	1,664,251	0			1,664,251	1,692,641
Town of Essex	1.50%	756,478	0			756,478	769,382
Town of Georgetown	5.13%	2,587,154	0			2,587,154	2,631,287
Town of Groveland	2.56%	1,291,055	0	10,191		1,301,246	1,323,443
Town of Hamilton	2.90%	1,462,523	0			1,462,523	1,487,471
Town of Ipswich	10.22%	5,154,135	0			5,154,135	5,242,057
Town of Lynnfield	7.45%	3,757,172	0			3,757,172	3,821,264
Town of Manchester	3.41%	1,719,726	0			1,719,726	1,749,062
Town of Merrimac	2.55%	1,286,012	0			1,286,012	1,307,949
Town of Middleton	6.38%	3,217,552	0			3,217,552	3,272,439
Town of Nahant	2.11%	1,064,112	0			1,064,112	1,082,264
Town of Newbury	2.14%	1,079,241	0			1,079,241	1,097,651
Town of North Andover	15.46%	7,796,763	0			7,796,763	7,929,764
Town of Rockport	5.04%	2,541,765	0			2,541,765	2,585,124
Town of Rowley	3.17%	1,598,689	0			1,598,689	1,625,960
Town of Salisbury	4.69%	2,365,254	0			2,365,254	2,405,602
Town of Topsfield	3.42%	1,724,769	0			1,724,769	1,754,191
Town of Wenham	2.02%	1,018,723	0			1,018,723	1,036,101
Town of West Newbury	1.94%	978,378	0			978,378	995,068
East. Essex Vet. Dist.	0.04%	20,173	0			20,173	20,517
No. And.-Box. Vet. Dist.	0.00%	0	0			0	0
North Essex Vet. Dist.	0.00%	0	0			0	0
Byfield Water Dist.	0.09%	45,389	0			45,389	46,163
Lynnfld. Ctr. Wat. Dist.	0.54%	272,332	0			272,332	276,978
Lynnfield Water Dist.	0.26%	131,123	0			131,123	133,360
NE Mass Mosq. Cont.	0.43%	216,857	0			216,857	220,556
Ham.-Wen. Reg. School	2.35%	1,185,148	0			1,185,148	1,205,365
Man-Essex Reg. School	1.36%	685,873	0		18,613	704,486	716,503
Masconomet Reg. School	1.75%	882,557	0			882,557	897,612
Pentucket Reg. School	2.66%	1,341,487	0			1,341,487	1,364,371
Triton Reg. School	3.42%	1,724,769	0			1,724,769	1,754,191
Essex Housing Authority	0.04%	20,173	0			20,173	20,517
Georgetown Hous. Auth.	0.15%	75,648	0			75,648	76,938
Groveland Hous. Auth.	0.06%	30,259	0			30,259	30,775
Hamilton Hous. Auth.	0.04%	20,173	0			20,173	20,517
Ipswich Housing Auth.	0.41%	206,771	0			206,771	210,298
Lynnfield Hous. Auth.	0.04%	20,173	0			20,173	20,517
Manchester Hous. Auth.	0.08%	40,345	0			40,345	41,033
Merrimac Hous. Auth.	0.04%	20,173	0			20,173	20,517
Middleton Hous. Auth.	0.05%	25,216	0			25,216	25,646
Nahant Housing Auth.	0.03%	15,129	0	10,974		26,103	26,548
No. Andover Hous. Auth.	0.41%	206,771	0			206,771	210,298

In accordance with your funding schedule, appropriations are due July 1 and January 1. Whenever payments are made at a date one month or more before the scheduled date or whenever payments are made one month or more after the scheduled date, PERAC's actuary should be contacted so that a revised amount can be calculated. Payments will be adjusted with interest at the rate assumed in the actuarial valuation used as the basis for your schedule. In no case may payments be made at a date beyond this fiscal year.

Essex Regional Retirement System FY25 Appropriation by Governmental Unit

Aggregate amount for appropriation for the Pension Fund: \$50,431,846
 Aggregate amount for appropriation for the Pension Reserve Fund: \$0
 Aggregate additional appropriation for the E.R.I.: \$55,622

<u>UNIT</u>	<u>PEN.FND. APP %</u>	<u>PENSION FUND APPROP.</u>	<u>PENSION RES. FUND APPROP.</u>	<u>ADD'L. APP. FOR E.R.I.</u>	<u>ADD'L. APP. FOR CRAB</u>	<u>TOTAL PAID JULY 1</u>	<u>APPROP SEMI-ANNUAL</u>
Rockport Hous.Auth.	0.15%	75,648	0			75,648	76,938
Rowley Hous. Auth.	0.04%	20,173	0		15,844	36,017	36,631
Salisbury Hous. Auth.	0.05%	25,216	0			25,216	25,646
Topsfield Hous.Auth.	0.04%	20,173	0			20,173	20,517
Wenham Housing Auth.	0.08%	40,345	0			40,345	41,033
W. Newbury Hous. Auth.	0.00%	0	0			0	0
TOTAL	100.00%	\$50,431,846	\$0	\$21,165	\$34,457	\$50,487,468	\$51,348,705

In accordance with your funding schedule, appropriations are due July 1 and January 1. Whenever payments are made at a date one month or more before the scheduled date or whenever payments are made one month or more after the scheduled date, PERAC's actuary should be contacted so that a revised amount can be calculated. Payments will be adjusted with interest at the rate assumed in the actuarial valuation used as the basis for your schedule. In no case may payments be made at a date beyond this fiscal year.

ARTICLE REQUEST FORM

ARTICLE: To see if the Town will vote to transfer from available funds an amount for contribution to the Other Post-Employment Benefits (OPEB) Stabilization Fund, or take any other action related

AMOUNT REQUESTED: \$21,586

CONTACT PERSON: Angus Jennings, Town Manager

PHONE NUMBER: 978-363-1100 x115

Why should the Town make this purchase? What needs will be met? Who will benefit?

Established at April 2010 Town Meeting, West Newbury's Other Postemployment Benefits (OPEB) Stabilization Fund is designed to provide benefits to the Town's eligible current and future retirees. This year's transfer to the fund is recommended at 10% of the June 30, 2023 OPEB liability as calculated by the Town's OPEB Actuary. An annual financial commitment to OPEB to ensure resources are available to meet the Town's future obligations is considered a "best financial practice" by the Massachusetts Department of Revenue and is recommended in the Town's Financial Policies.

What factors affect the timing of this purchase?

This will allow the Town to plan and save ahead to meet this obligation when the Town finances permit, thereby avoiding the need for abrupt tax increases.

When should this Article be sunsetted - how long will the project take?

FY25

What ancillary costs do you anticipate? (Maintenance, Insurance, Training, etc.)

None

Does this Article involve improvement, preservation or creation of tangible Town-owned assets and projects which 1) have useful life of at least five years; 2) cost over \$20,000 and or 3) for which the Town is authorized to borrow funds? If so, please confirm that this item is on the Capital Improvements Committee Schedule for future capital investments.

No

Please attach additional pages or other supporting documentation.



TOWN OF WEST NEWBURY, MASSACHUSETTS

OTHER POSTEMPLOYMENT BENEFITS PROGRAM

FINANCIAL REPORTING AND DISCLOSURES
Governmental Accounting Standards Board
Statements 74 and 75

Disclosures as of
June 30, 2023

KMS Actuarial, LLC
52 Hunt Road
Kingston, NH 03848

September, 2023

TABLE OF CONTENTS

EXECUTIVE SUMMARY	1
SECTION 1 PRINCIPAL VALUATION RESULTS	5
Exhibit 1.1 - OPEB Trust Assets	
Exhibit 1.2 - Total OPEB Liability	
Exhibit 1.3 - Development of Actuarially Determined Employer Contributions	
SECTION 2 NOTES TO THE FINANCIAL STATEMENTS	8
Exhibit 2.1 - Plan Description	
Exhibit 2.2 - Net OPEB Liability	
SECTION 3 SCHEDULES OF REQUIRED SUPPLEMENTARY INFORMATION	12
Exhibit 3.1 - Changes in Net OPEB Liability and Related Ratios	
Exhibit 3.2 - Investment Returns	
Exhibit 3.3 - Schedule of Employer Contributions	
SECTION 4 EMPLOYER REPORTING AMOUNTS UNDER GASB 75	19
Exhibit 4.1 - Deferred Outflows and Deferred Inflows of Resources	
Exhibit 4.2 - OPEB Expense	
SECTION 5 SUMMARY OF PLAN PROVISIONS	22
SECTION 6 ACTUARIAL ASSUMPTIONS AND METHODS	23
SECTION 7 PLAN MEMBER INFORMATION	29
Exhibit 7.1 - Active Members by Age and Years of Service	
Exhibit 7.2 - Retired Members, Covered Spouses and Survivors	
SECTION 8 GLOSSARY OF TERMS	31
SECTION 9 BREAKOUT OF RESULTS BY DEPARTMENT	34
Appendix A CALCULATION OF SINGLE DISCOUNT RATE	
Appendix B SCHEDULE OF DEFERRED OUTFLOWS OF RESOURCES and DEFERRED INFLOWS OF RESOURCES	

EXECUTIVE SUMMARY

Purpose of Report

This report presents the results of the actuarial valuation of the Town of West Newbury's retiree health care benefits as of July 1, 2022. The valuation was prepared in accordance with and for the purpose of financial reporting and disclosures as of June 30, 2023 under the following Governmental Accounting Standards Board (GASB) Statements:

- ◆ GASB Statement No. 74, Financial Reporting for Postemployment Benefit Plans Other Than Pension Plans (GASB 74)
- ◆ GASB Statement No. 75, Accounting and Financial Reporting for Postemployment Benefits Other Than Pensions (GASB 75)

The results as of the measurement date are based on a roll forward of the liabilities developed in the most recent actuarial valuation.

GASB Accounting Standards

In June 2015, the GASB approved two related Statements that significantly changed the way other postemployment benefits (OPEB) plans and governments account and report OPEB liabilities. GASB Statement No. 74 (GASB 74), *Financial Reporting for Postemployment Benefit Plans Other Than Pension Plans*, replaced the requirements of Statement No. 43 and GASB Statement No. 75 (GASB 75), *Accounting and Financial Reporting for Postemployment Benefits Other Than Pensions*, replaced the requirements of Statement No. 45.

The effective date for GASB 74 is for plan years beginning after June 15, 2016, which is the plan year ending June 30, 2017 for the Town of West Newbury. The effective date for GASB 75 is for fiscal years beginning after June 15, 2017, which is the fiscal year ending June 30, 2018 for the Town of West Newbury.

GASB 74 requires OPEB plans to present a statement of fiduciary net position (OPEB plan assets) and a statement of changes in fiduciary net position. Further, the statement requires that notes to financial statements include descriptive information such as the types of benefits provided, the classes of plan members covered and the authority under which benefit terms are established or may be amended. Finally, GASB 74 requires OPEB plans to present in required supplementary information the sources of the changes in the net OPEB liability and information about the actuarially determined contributions compared with the actual contributions made to the plan and related ratios.

GASB 74 and GASB 75 require projected benefit payments be discounted to their actuarial present value using the single rate that reflects (1) a long-term expected rate of return on OPEB plan investments to the extent that the OPEB plan's assets are sufficient to pay benefits and OPEB plan assets are expected to be invested using a strategy to achieve that return and (2) a tax-exempt, high-quality municipal bond rate to the extent that the conditions for use of the long-term expected rate of return are not met.

GASB 75 establishes standards for measuring and recognizing liabilities, deferred outflows of resources, deferred inflows of resources and OPEB expense by state and local governments.

EXECUTIVE SUMMARY

Town of West Newbury Other Postemployment Benefits Program

The Town of West Newbury administers the retiree health care benefits program - a single-employer defined benefit plan that is used to provide postemployment benefits other than pensions (OPEB) for all permanent full-time employees. The Town provides health care benefits for retirees and their dependents. Benefits are provided through the Massachusetts Interlocal Insurance Association, and the full cost of benefits is shared between the Town and retirees.

Summary of Principal Results

A summary of principal results from the current and prior measurement dates follows:

Disclosure Date	June 30, 2023	June 30, 2022	% Change
Valuation Date	July 1, 2022	July 1, 2020	
Membership Data			
Active Plan Members	49	44	11.4%
Inactive Plan Members (excludes covered spouses)	18	18	0.0%
Total Plan Members	67	62	8.1%
Covered Spouses	6	6	0.0%
Covered Payroll	\$3,062,556	\$3,029,899	1.1%
Net OPEB Liability			
Discount Rate	5.80%	6.00%	
Total OPEB Liability (TOL)	\$3,002,186	\$2,907,896	3.2%
Fiduciary Net Position (FNP)	\$2,786,326	\$2,564,519	8.6%
Net OPEB Liability	\$215,860	\$343,377	(37.1%)
FNP as % of TOL	92.8%	88.2%	
OPEB Expense			
OPEB Expense	\$213,112	\$192,144	10.9%
Deferred Outflows	\$449,987	\$490,787	
Deferred Inflows	\$414,396	\$201,704	
Recognition Period	8.28	7.47	

EXECUTIVE SUMMARY

Experience Gain and Loss

In developing the Total OPEB Liability, various assumptions are made regarding future premium rates, mortality, retirement, disability and turnover rates. A comparison of the results of the current and prior measurements is made to determine how closely actual experience relates to expected. For the current measurement period, the difference between expected and actual experience resulted in an actuarial gain of approximately \$284,000. This gain is primarily attributable to the following:

- ◆ a gain due to a lower than expected increase in medical premiums
- ◆ a gain due to high active employee turnover replaced by lower service employees
- ◆ a gain due to more retiree deaths than expected
- ◆ a loss due to a high-service employee who was not included in the prior valuation because they became a full-time employee in FY2023

Changes of Assumptions

The discount rate changed from 6% as of June 30, 2022 to 5.8% as of June 30, 2023. In addition, many other assumptions were updated in this valuation, including the inflation rate, healthcare trend rates, and mortality tables and mortality improvement rates. A summary of the impact on the Total OPEB Liability (TOL) of each assumption change is provided below:

◆ Decrease due to change in Inflation Assumption	(6,000)
◆ Increase due to change in Trend Assumption	119,000
◆ Decrease due to change in Mortality Tables and Mortality Improvement Rates	(28,000)
◆ Increase due to change in Discount Rate	76,000
Total	\$ 161,000

All of the assumptions used in this valuation are shown in Section 6, Actuarial Assumptions and Methods.

Changes of Benefit Terms

All benefit terms are the same as those used in the prior measurement. A Summary of the Principal Plan Provisions is provided in Section 5.

Total OPEB Liability

The Total OPEB Liability as of the current measurement date, June 30, 2023, is \$3,002,186. The Total OPEB Liability as of the prior measurement date, June 30, 2022, was \$2,907,896. During the current measurement period ending June 30, 2023, the Total OPEB Liability increased by \$94,290, or 3.2%. The development of the Total OPEB Liability for the current measurement period is shown in Section 1, Exhibit 1.2.

Fiduciary Net Position

The Fiduciary Net Position is equal to the market value of assets and as of the current measurement date, June 30, 2023, is \$2,786,326. The Fiduciary Net Position as of the prior measurement date, June 30, 2022, was \$2,564,519. During the plan years ended June 30, 2023 and June 30, 2022, the actual rates of return were 8.65% and -10.66%, respectively. The expected long-term rate of return is 5.80%. The Fiduciary Net Position is shown in Section 1, Exhibit 1.1.

EXECUTIVE SUMMARY

Employer Future Period Contributions

The Town will analyze a variety of funding strategies and subsequently implement them as appropriate with the intention of fully funding the obligation. Currently, the Town expects to contribute \$25,500 from FY2025 through FY2061 in order to fully fund benefit payments for current plan members.

Discount Rate

As of the June 30, 2023 measurement date, the OPEB plan's fiduciary net position was projected to be available to make all projected future benefit payments of current plan members. Therefore, the long-term expected rate of return on OPEB plan investments was applied to all periods of projected benefit payments to determine the total OPEB liability. Projected benefit payments are discounted to their actuarial present value using a single discount rate of 5.8%.

OPEB Expense

The OPEB Expense for the current measurement period ending June 30, 2023, is \$213,112. Benefit changes are recognized immediately and experience gains and losses and assumption changes developed in this valuation are recognized over 8.28 years. Investment gains and losses are recognized over 5 years. The OPEB Expense for the prior measurement period was \$192,144. The development of the OPEB expense for the current measurement period is shown in Section 4, Exhibit 4.2.

COVID-19 Pandemic

The assumptions in this report, other than medical trend rates in the short term, do not reflect the potential impact of the COVID-19 pandemic on the OPEB program. Especially in the short range, it is very likely that the pandemic materially affected the economic, demographic and healthcare-specific experience in a way not anticipated by the assumptions on which the projections are based.

ARTICLE REQUEST FORM

ARTICLE: To see if the Town will vote to appropriate a sum of money from the PEG Access and Cable Related Fund for the purposes of funding its FY25 cable-related expenses; or take any other action relative thereto.

AMOUNT REQUESTED: TBD

CONTACT PERSON: Kelly Scott, Cable Advisory Committee Chair

PHONE NUMBER: kscott72@verizon.net

Why should the Town make this purchase? What needs will be met? Who will benefit?

ARTICLE __: PEG Access Receipt Reserved for Appropriation

Summary: A vote taken at the 2015 Annual Town Meeting established a Receipt Reserved for Appropriation fund for the cable access agreement pertaining to the Verizon and Comcast licensing agreements. This account was created in accordance with DOR guidelines. Monies accrued in this account are proposed to be appropriated to fund cable operations. The Town receives quarterly franchise fees from Verizon and Comcast for eligible Public/Educational/Governmental (PEG) costs. A majority vote is required for the passage of this article.

What factors affect the timing of this purchase?

Annual article to appropriate PEG funds.

When should this Article be sunsetted - how long will the project take?

N/A

What ancillary costs do you anticipate? (Maintenance, Insurance, Training, etc.)

Cable operations and related costs would continue to be funded entirely from PEG revenues.

Does this Article involve improvement, preservation or creation of tangible Town-owned assets and projects which 1) have useful life of at least five years; 2) cost over \$20,000 and or 3) for which the Town is authorized to borrow funds? If so, please confirm that this item is on the Capital Improvements Committee Schedule for future capital investments.

No

Please attach additional pages or other supporting documentation.

ARTICLE REQUEST FORM

ARTICLE: Set maximum receipts and expenditures from Revolving Funds in FY25
AMOUNT REQUESTED: N/A. (Costs are expended from non-tax receipts into the Revolving Funds)
CONTACT PERSON: Angus Jennings, Town Manager
PHONE NUMBER: 978-363-1100 x115

Why should the Town make this purchase? What needs will be met? Who will benefit?

This is a required annual vote. Revolving Funds are established by vote of Town Meeting, and are set forth in the Town Bylaws Sec. XL Departmental Revolving Funds (see Town Website / Bylaws and Policies link / Town Bylaws). The Town Accountant prepared an analysis of revenues into, and costs out of, each revolving fund, and this is enclosed for review. The enclosed IGR from MassDOR also details procedures and requirements regarding Revolving Funds. The proposed article, with proposed amounts, follows:

To see if the Town, in accordance with Massachusetts General Laws Chapter 44, Sec. 53E1/2, and Section XL of the Bylaws of the Town of West Newbury, will fix the maximum amounts that may be spent during the fiscal year beginning on July 1, 2024 for the revolving funds established in town bylaws, as set forth below for certain departments, boards, committees, agencies or officers, with such expenditure limits to be applicable for each fiscal year until such time as Town Meeting votes, prior to July 1 for the ensuing fiscal year, to revise the same; or take any other action relative thereto:

- Section 5.1 Summer Recreation Revolving Fund \$ 75,000 (unchanged)
- Section 5.2 GAR Library Fines and Penalties Revolving Fund \$ 10,000 (unchanged)
- Section 5.3 Police Vehicle Revolving Fund \$ 20,000 (unchanged)
- Section 5.4 Pipestave/Mill Pond Care and Maintenance Revolving Fund \$ 5,000 (unchanged)
- Section 5.5 Electric Vehicle Charging Stations Revolving Fund \$ 10,000 (unchanged)
- Section 5.6 Curbside Collection of Trash, Recycling and Food Waste Revolving Fund \$ 50,000 (unchanged)
- Section 5.7 Council on Aging Revolving Fund \$ 30,000 (created at STM 10.23.23 amount unchanged)

What factors affect the timing of this purchase?

This is a required annual Town Meeting vote.

When should this Article be sunsetted - how long will the project take?

N/A. Per MGL, this vote would apply to FY25.

What ancillary costs do you anticipate? (Maintenance, Insurance, Training, etc.)

In some cases, expenses paid from Revolving Funds offset costs that may otherwise be paid from the Operating Budget. Examples include the Police Cruiser Revolving Fund, which has been drawn on annually to offset the expense to maintain the Police Cruiser fleet (and directly reduces the proposed Operating Budget). Please note: unlike the Revolving Funds included in the proposed Article, the Park & Rec Revolving Fund does not require Town Meeting appropriation. This Revolving Fund was adopted by Town Meeting on 4/26/99 and, per MGL Ch. 44 Sec. 53D, these funds may be expended at the direction of the Parks & Rec Commission, with Town Manager approval, but without further appropriation (i.e. no Town Meeting vote).

Does this Article involve improvement, preservation or creation of tangible Town-owned assets and projects which 1) have useful life of at least five years; 2) cost over \$20,000 and or 3) for which the Town is authorized to borrow funds? If so, please confirm that this item is on the Capital Improvements Committee Schedule for future capital investments.

No.

Please attach additional pages or other supporting documentation.

ARTICLE REQUEST FORM

ARTICLE: Community Preservation Act, Annual Budget Article for CPA Funding for Fiscal Year 2024, Annual Town Meeting Warrant

AMOUNT REQUESTED: \$XXX,XXX

CONTACT PERSON: Wendy Reed, Chair

PHONE NUMBER: cpc@wnewbury.org

Why should the Town make this purchase? What needs will be met? Who will benefit?

ARTICLE: To see if the Town will vote to appropriate or reserve from the Community Preservation Fund annual revenues in the amounts recommended by the Community Preservation Committee (CPC) for committee administrative expenses, community preservation projects and other expenses in Fiscal Year 2024, with each item to be considered a separate appropriation.

Appropriations:

From FY 2024 estimated revenues for Committee Administrative Expenses: \$XX,XXX

Reserves:

From FY 2024 estimated revenues for Community Housing Reserve \$XX,XXX

From FY 2024 estimated revenues for Historic Resources Reserve \$XX,XXX

From FY 2024 estimated revenues for Open Space & Recreation Reserve \$XX,XXX

From FY 2024 estimated revenues for Budgeted Reserve \$XXX,XXX

Sponsored by the Community Preservation Committee

The Community Preservation Committee voted X-Y on February XX, 2024 to approve this Article and to submit it to the Town Manager for inclusion on the Annual Town Meeting Warrant.

Please note that if the Department of Revenue releases estimates of a state match prior to the posting of the Warrant, or a date specified by the Town Manager, the CPC may submit updated estimates for the Warrant article.

What factors affect the timing of this purchase?

N/A

When should this Article be sunsetted - how long will the project take?

N/A

What ancillary costs do you anticipate? (Maintenance, Insurance, Training, etc.)

N/A

Does this Article involve improvement, preservation or creation of tangible Town-owned assets and projects which 1) have useful life of at least five years; 2) cost over \$20,000 and or 3) for which the Town is authorized to borrow funds? If so, please confirm that this item is on the Capital Improvements Committee Schedule for future capital investments.

N/A

Please attach additional pages or other supporting documentation.

ARTICLE REQUEST FORM

ARTICLE: Annual transfer of CPA Community Housing funds to the Affordable Housing Trust

AMOUNT REQUESTED: \$xx,xxx - TBD

CONTACT PERSON: Wendy Reed, CPC and AHT Chair

PHONE NUMBER: 978-363-1100 x115

Why should the Town make this purchase? What needs will be met? Who will benefit?

The Affordable Housing Trust was established for the purpose of supporting and creating low and moderate income housing in West Newbury. As this is their sole focus, they are in a better position to evaluate the resources, needs and priorities for this use. The AHT and CPC entered into a grant agreement in 2023 that defines the uses and responsibilities associated with these funds. This will be reviewed annually, along with the request to transfer the previous year's Community Housing allocation.

What factors affect the timing of this purchase?

The amount of each fiscal year's allocation is not known until November of the following fiscal year. As a result, the annual transfer request will be for the prior fiscal year's balance of the Community Housing portion of the CPA.

When should this Article be sunsetted - how long will the project take?

Once approved, the transfer may happen immediately

What ancillary costs do you anticipate? (Maintenance, Insurance, Training, etc.)

None

Does this Article involve improvement, preservation or creation of tangible Town-owned assets and projects which 1) have useful life of at least five years; 2) cost over \$20,000 and or 3) for which the Town is authorized to borrow funds? If so, please confirm that this item is on the Capital Improvements Committee Schedule for future capital investments.

No

Please attach additional pages or other supporting documentation.



Town of West Newbury Select Board

381 Main Street, West Newbury, MA 01985 | 978-363-1100, Ext. 115
selectboard@wnewbury.org

COMMUNITY PRESERVATION ACT GRANT AGREEMENT

AFFORDABLE HOUSING TRUST

This GRANT AGREEMENT made this 7th day of August, 2023 by and between the Town of West Newbury, a municipal corporation duly organized under the laws of Massachusetts and having an address of 381 Main Street, West Newbury, MA 01985, (the “TOWN”) acting by and through its Select Board, and the Trustees (the “TRUSTEES”) of the West Newbury Municipal Affordable Housing Trust, established pursuant to G.L. c. 44 Section 55C, having its principal place of business at 381 Main Street, West Newbury, MA 01985 (the “GRANTEE” or the “TRUST”).

WITNESSETH

WHEREAS, Town Meeting voted under Article 12 of the Special Town Meeting held October 23, 2021 to establish a municipal affordable housing trust under M.G. L. c. 44 Section 55C as, among other things, a mechanism to utilize annual revenues for community housing consistent with the Community Preservation Act, G.L. c. 44B (the “CPA” or the “Act”); and

WHEREAS, upon recommendation of the Community Preservation Committee “CPC” or “COMMITTEE”), Town Meeting voted under Article 29 of the Annual Town Meeting held May 14, 2022 to adopt the Municipal Affordable Housing Trust Bylaw (“Bylaw”), which describes the membership, operation and limitations on the TRUST; and

WHEREAS, A Declaration of Trust is recorded at So. Essex #197 Bk 41431 Pg: 1; and

WHEREAS, Town Meeting voted under Article 15 of the Annual Town Meeting held April 24, 2023 to appropriate \$172,178.00 (“Grant Funds”) from CPA Community Housing Funds to the TRUST for uses consistent with the purposes of the TRUST as defined in the bylaw and Declaration of Trust; and

WHEREAS, Town Meeting may vote to appropriate additional money from CPA Community Housing Funds to the TRUST annually or for specific Community Housing projects in the future; and

WHEREAS, General Laws c.30B, §2 defines a grant agreement as “an agreement between a governmental body and an individual or nonprofit entity the purpose of which is to carry out a public purpose of support or stimulation instead of procuring supplies or services for the benefit or use of the governmental body”; and

WHEREAS, the expenditure of public funds must be for public purposes and not unfairly or primarily benefit any one group or organization to the detriment of the public.

WHEREAS, the purpose of the Grant Agreement is to ensure that the CPA Community Housing Funds are used for the acquisition, creation, preservation and support of community housing, as defined by the CPA (Massachusetts General Laws c. 44B).

NOW, THEREFORE, the TOWN and the GRANTEE wish to set forth in this Grant Agreement the terms and conditions of the Grant, and hereby agree as follows:

1. Recitals. The recitals above are true and accurate and are incorporated herein by reference.
2. Payment. Within thirty (30) days from the execution of this Grant Agreement, the TOWN shall transfer the sum of \$172,178.00 from CPA Community Housing Funds to GRANTEE, in accordance with Town Meeting vote.
3. Conditions.
 - a) GRANTEE agrees that any dwelling units created or acquired with the use of the Grant funds, whether in part or in full, shall be used for community housing purposes, as that term is defined in Section (2) of the Act, in perpetuity. Sale or transfer of the dwelling shall be subject to an affordable housing deed rider requiring occupancy by or rented to low- or moderate-income households, and no other sale or transfer shall be permitted. GRANTEE acknowledges that Section 12(a) of the Act states that “a real property interest that is acquired with monies from the Community Preservation Fund shall be bound by a permanent restriction, recorded as a separate instrument, that meets the requirements of sections 31 to 33, inclusive, of chapter 184 limiting the use of the interest to the purpose for which it was acquired. The permanent restriction shall run with the land and shall be enforceable by the TOWN, the Commonwealth, and/or a nonprofit or charitable organization. The deed restrictions must be approved and accepted by the TOWN.
 - b) Notwithstanding GRANTEE’S bylaws, all Grant Funds expended pursuant to this Agreement shall be limited to the allowable community housing spending purposes as set forth in Sections 2 and 5(c) of the CPA.

- c) Until all the Grant Funds have been expended, GRANTEE shall prepare and submit to the CPC quarterly reports concerning the use of such monies, which report shall outline the purposes for which the Grant Funds have been used and any problems encountered. GRANTEE shall submit these reports in writing and may be requested to make oral presentations at CPC or Select Board meetings. GRANTEE shall provide a final report immediately following its final expenditure of all the Grant Funds.
 - d) Any publicity involving the use of the Grant Funds by the GRANTEE shall include explicit reference to the CPC.
4. Reports; Inspections; Record-Keeping. GRANTEE agrees to keep such records with respect to the use of the Grant Funds as are kept in the normal course of business and such additional records as may be reasonably required by the TOWN. During normal business hours and as often as the TOWN may reasonably deem necessary, the TOWN shall have full and free access to such records and may examine and copy such records. As specified in Section 3(f), above, the GRANTEE shall report quarterly to the TOWN concerning its use of the Grant Funds.
 5. Liability of the Town. The TOWN's liability hereunder shall be to make the payment specified in Paragraph 1 of this Grant Agreement and the TOWN shall be under no further obligation or liability. Nothing in this Grant Agreement shall be construed to render the TOWN or any elected or appointed official or employee of the TOWN, or their successors in office, personally liable for any obligation under this Grant Agreement.
 6. Indemnification. GRANTEE shall indemnify, defend, and hold the TOWN and its departments, officers, employees, representatives and agents harmless from and against any and all claims, demands, liabilities, actions, causes of actions, costs and expenses, including attorneys' fees, of any nature whatsoever arising as a result of (a) any injury to person or property resulting from expenditure of the Grant Funds, (b) the quality of any work required or undertaken with use of the Grant Funds, (c) GRANTEE's performance or the negligence or misconduct of GRANTEE or GRANTEE's agents, employees, contractors and invitees, (d) the failure of any contractor hired by GRANTEE to perform work thereunder or any other act or omission of any such contractor, and (e) any and all claims for the payment by the TOWN of any amount in excess of the Grant Amount.
 7. Termination. This Agreement shall terminate upon GRANTEE'S final expenditure of all the Grant Funds and the delivery of copies of the restrictions recorded pursuant to Section 3(A) hereof, if any. In the event that GRANTEE fails to fulfill its obligations under the terms of this Agreement as determined by the Town, the Town shall have the right, in its sole discretion, to terminate this Agreement upon written notice to GRANTEE. Upon receipt of such

notice, GRANTEE shall refund all undisbursed Grant Funds to the TOWN, and such Grant Funds shall be returned to the CPA account from which the funds were appropriated.



8. Return of Funds. If GRANTEE fails to fulfill its obligations under the terms of this Agreement as a result of negligent or intentional acts or omissions of GRANTEE, its agents, employees, contractors or invitees, GRANTEE shall be liable to repay to the TOWN the entire Grant Amount, or any lesser amount it received pursuant to this Agreement, provided under this Agreement, and the TOWN may take such steps as are necessary, including legal action, to recover such funds. Any funds so returned or recovered shall be placed in the TOWN'S Community Preservation Fund. In the event that the TOWN takes legal action under this Agreement, GRANTEE shall pay any and all costs, including reasonable attorneys' fees, expended by the TOWN for the enforcement of this Agreement.
9. Successors and Assigns. This Agreement is binding upon the parties hereto, their successors, assigns and legal representatives. GRANTEE shall not assign, subcontract or otherwise transfer this Agreement, in whole or in part, without the prior written consent of the TOWN.
10. Compliance with Laws. GRANTEE shall comply with all Federal, State and local laws, rules, regulations and orders applicable to the use of the Grant Funds, such provisions being incorporated herein by reference, and shall be responsible for obtaining all necessary licenses, permits, and approvals as may be required in connection with the use of such funds. No local permit or license is waived by the award of this Grant or by this Agreement.
11. Notice. Any and all notices, or other communications required or permitted under this Agreement shall be in writing and delivered by hand or mailed postage prepaid, return receipt requested, by registered or certified mail or by other reputable delivery service, to the parties at the addresses set forth on Page 1 or furnished from time to time in writing hereafter by one party to the other party. Any such notice or correspondence shall be deemed given when so delivered by hand, if mailed, when deposited with the U.S. Postal Service or, if sent by private overnight or other delivery service, when deposited with such delivery service.
12. Survival. Notwithstanding anything to the contrary herein contained, the obligations imposed on the GRANTEE under Sections 3-11, 13 and 16 shall survive the termination or expiration of this Agreement.
13. Entire Agreement. This Agreement, and all documents incorporated herein by reference, constitutes the entire integrated agreement between the parties with respect to the matters described. This Agreement supersedes all prior agreements, negotiations and representations, either written or oral, and it shall

not be modified or amended except by a written document executed by the parties hereto.

14. Renewal. This Grant Agreement shall be renewed annually, coincident with the application for and Town Meeting approval of annual transfer of CPA Community Housing Funds to the GRANTEE. A separate Grant Agreement shall be created for any other CPA Fund disbursements to the GRANTEE.
15. Severability. If any term or condition of this Grant Agreement or any application thereof shall to any extent be held invalid, illegal or unenforceable by a court of competent jurisdiction, the validity, legality, and enforceability of the remaining terms and conditions of this Grant Agreement shall not be deemed affected thereby unless one or both parties would be substantially or materially prejudiced.
16. Governing Law. This Grant Agreement shall be governed by, construed and enforced in accordance with the laws of the Commonwealth of Massachusetts and the GRANTEE submits to the jurisdiction of any of its appropriate courts in Essex County, MA for the adjudication of disputes arising out of this Grant Agreement.
17. Counterparts. This Agreement may be executed in several counterparts, each of which shall be an original and which shall constitute the same instrument. The exchange of counterparts by electronic or facsimile transmission (including telecopier and scanned "PDF" transmitted by email) shall constitute effective execution and delivery of this Agreement by the parties hereto. Signatures of Town and GRANTEE delivered by electronic or facsimile transmission (including telecopier and scanned "PDF" transmitted by email) shall be deemed to be their original signatures for all purposes.

The remaining part of the page is left blank.

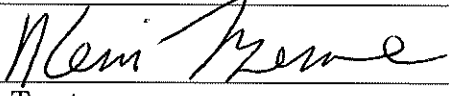
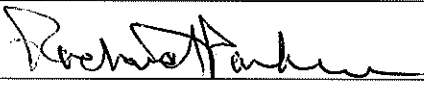
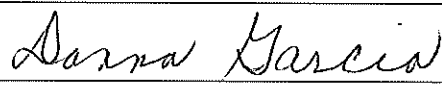
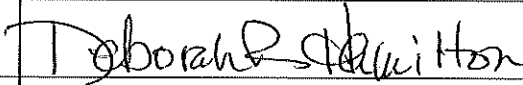
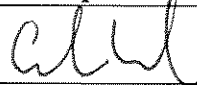
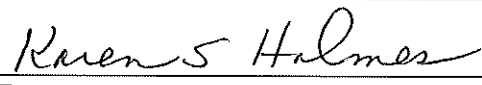
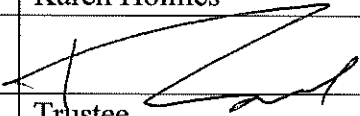
IN WITNESS WHEREOF, the parties hereto have executed this Grant Agreement on the day and year first written above.

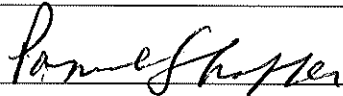
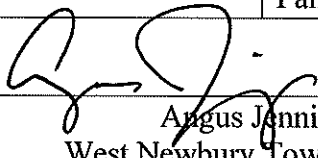
Town of West Newbury SELECT BOARD	Town of West Newbury AFFORDABLE HOUSING TRUST
	
Chair Wendy Reed	Trustee Kevin Bowe
	
Vice Chair Richard Parker	Trustee Donna Garcia
	
Clerk Christopher Wile	Trustee Deborah Hamilton
	
	Trustee Karen Holmes
	
	Trustee Derek Mitchell
	
	Trustee Wendy Reed
	Trustee Pamela Shaffer 
	
Angus Jennings West Newbury Town Manager	

ARTICLE REQUEST FORM

ARTICLE:

AMOUNT REQUESTED:

CONTACT PERSON:

PHONE NUMBER:

Why should the Town make this purchase? What needs will be met? Who will benefit?

What factors affect the timing of this purchase?

When should this Article be sunsetted--how long will the project take?

What ancillary costs do you anticipate? (Maintenance, Insurance, Training, etc.)

Does this Article involve improvement, preservation or creation of tangible Town-owned assets and projects which 1) have useful life of at least five years; 2) cost over \$20,000 and or 3) for which the Town is authorized to borrow funds? If so, please confirm that this item is on the Capital Improvements Committee Schedule for future capital investments.

Please attach additional pages or other supporting documentation.

**TOWN OF WEST NEWBURY
COMMUNITY PRESERVATION COMMITTEE**

APPLICATION FOR PROJECT ELIGIBILITY

This application may be completed electronically and emailed to cpc@wnewbury.org or printed and completed by hand and submitted to the CPC Administrator. All applications must be received by the CPC Office at least 2 weeks prior to a scheduled meeting in order to be considered by the Committee. For more information contact 978-363-1100 X131.

APPLICANT INFORMATION:

Project Name:	Pickleball Site Feasibility Study
Project Address:	To be determined
Map/Lot:	To be determined
Applicant Name: (Group or Committee Affiliation)	West Newbury Select Board
Contact Person:	Angus Jennings
Telephone:	(978) 363-1100 x111
Address:	381 Main Street West Newbury, MA 01985
Email:	townmanager@wnewbury.org
Date of Application:	January 2, 2024

COMMUNITY PRESERVATION CATEGORY: *(Consult guidelines on following page and check all that apply)*

<input type="checkbox"/>	Open Space
<input checked="" type="checkbox"/>	Recreation
<input type="checkbox"/>	Historic Preservation
<input type="checkbox"/>	<ul style="list-style-type: none"> • Eligible/On State Registry
<input type="checkbox"/>	<ul style="list-style-type: none"> • Designated by Historic Commission
<input type="checkbox"/>	Community Housing

**TOWN OF WEST NEWBURY
COMMUNITY PRESERVATION COMMITTEE**

APPLICATION FOR PROJECT ELIGIBILITY

CPA ELIGIBILITY REQUIREMENTS				
	Open Space	Recreation	Historic	Housing
Acquire	Yes	Yes	Yes	Yes
Create	Yes	Yes	No	Yes
Preserve	Yes	Yes	Yes	Yes
Support	No	No	No	Yes
Rehabilitate and/or Restore	Yes, if acquired or created with CPA funds	Yes (New 7/8/2012)	Yes	Yes If acquired or created with CPA funds
Adapted from "Recent Developments in Municipal Law", Massachusetts Department of Revenue, October 2012				

General Criteria

The Community Preservation Committee will give preference to proposals which address as many of the following general criteria as possible:

- Are consistent with the planning documents that have received wide scrutiny, public input and have been adopted by the Town such as the Open Space and Recreation Plan, Capital Improvement Plan and Master Plan;
- Preserve and enhance the character of the town;
- Save resources that would otherwise be threatened;
- Serves a currently under-served population;
- Either serve more than one CPA purpose (especially in linking open space, recreation and community housing) or demonstrate why serving multiple needs is not feasible;
- Demonstrate practicality and feasibility; demonstrate that the project can be implemented expeditiously and within budget;
- Produce an advantageous cost/benefit value;
- Leverage additional public and/or private funds;
- Preserve or utilize current town-owned assets; and
- Receive endorsement by other municipal boards or departments as well as community groups.

**TOWN OF WEST NEWBURY
COMMUNITY PRESERVATION COMMITTEE**

APPLICATION FOR PROJECT ELIGIBILITY

PROJECT DESCRIPTION:

<p>Provide a description of the project:</p> <p>Pickleball courts are a popular commodity in many areas of the country and especially in this region. West Newbury does not currently have courts for its residents to play on and residents have expressed an interest in the possibility of constructing outdoor courts in West Newbury. This feasibility study will look at Town owned parcels that could be developed to accommodate outdoor pickleball play, including courts, parking, fencing and other amenities. The study will provide preparation of GIS base plans, site evaluation including utility constraints and permitting requirements, schematic designs and an estimate of probable cost for design, site work and construction.</p>
<p>How is this project consistent with the goals of the CPA?</p> <p>This project is the first step in the process of siting and constructing pickleball courts in West Newbury. This long-term effort will expand the types of recreational opportunities offered in West Newbury to residents of all ages. Most organized recreational activities in Town are for youth, while pickleball is played by people of all ages, most notably senior citizens. It will utilize property that is currently Town owned, thus maximizing the use of Town resources. Many other towns have used CPA funds to complete Pickleball Court Feasibility Studies, Design and Construction, so this use has been established as appropriate.</p>
<p>What is the intended timeline of the project?</p> <p>The project will be completed over a eight-month period beginning in July 2024.</p>

FUNDING:

Estimated funding needed for this project:	\$ 22,000 (to be refined in Funding Application)
CP funding requested:	\$ 22,000

OTHER:

<p>Please attach any other information which you think would be useful for the CPC to consider when evaluating this project's eligibility for funding.</p>
--

ARTICLE REQUEST FORM

ARTICLE: Sawmill Brook Conservation Area Trail Design and Permitting

AMOUNT REQUESTED: TBD during CPA Funding Application preparation and review by the CPC on February 24, 2024

CONTACT PERSON: Angus Jennings

PHONE NUMBER: 978-363-1100 x111

Why should the Town make this purchase? What needs will be met? Who will benefit?

This project is for the design, engineering and permitting of a trail system connecting recorded easements on the site of the recently-constructed Deer Run Subdivision (located off Main Street, generally across the street from Long Hill Orchard), across the Town's newly-acquired Sawmill Brook Conservation Area (purchase of land closed on Dec. 15, 2024), and connecting to an existing trail located on the Mill Pond conservation area. The intent of the new trail system will be to expand the existing passive recreational opportunities offered at the Town's Mill Pond/Pipestave Hill Conservation Area. It will improve public access for residents of all ages to walking, cycling, wildlife observation and equestrian use.

What factors affect the timing of this purchase?

This phase of the project must be completed in order to estimate the cost of the trail network project and solicit funding from a subsequent CPA application or grant funding.

When should this Article be sunsetted—how long will the project take?

This phase of the project will take 6 months to a year or more, depending on permitting requirements. A sunset date of June 30, 2026 is recommended.

What ancillary costs do you anticipate? (Maintenance, Insurance, Training, etc.)

N/A

Does this Article involve improvement, preservation or creation of tangible Town-owned assets and projects which 1) have useful life of at least five years; 2) cost over \$20,000 and or 3) for which the Town is authorized to borrow funds? If so, please confirm that this item is on the Capital Improvements Committee Schedule for future capital investments.

N/A

Please attach additional pages or other supporting documentation.

**TOWN OF WEST NEWBURY
COMMUNITY PRESERVATION COMMITTEE**

APPLICATION FOR PROJECT ELIGIBILITY

This application may be completed electronically and emailed to cpc@wnewbury.org or printed and completed by hand and submitted to the CPC Administrator. All applications must be received by the CPC Office at least 2 weeks prior to a scheduled meeting in order to be considered by the Committee. For more information contact 978-363-1100 X131.

APPLICANT INFORMATION:

Project Name:	Sawmill Brook Conservation Area Trail
Project Address:	Archelaus Place and Poor House Lane
Map/Lot:	Map R14, Lots 30 and 30F; and Poor House Lane right-of-way (no Assessors' Map/Lot)
Applicant Name: (Group or Committee Affiliation)	West Newbury Select Board
Contact Person:	Angus Jennings, Town Manager
Telephone:	978-363-1100 x111
Address:	381 Main Street, West Newbury, MA 01985
Email:	Townmanager@wnewbury.org
Date of Application:	01/19/24

COMMUNITY PRESERVATION CATEGORY: *(Consult guidelines on following page and check all that apply)*

- | | |
|--------------------------|---|
| X | Open Space |
| <input type="checkbox"/> | Recreation |
| <input type="checkbox"/> | Historic Preservation |
| <input type="checkbox"/> | <ul style="list-style-type: none"> • Eligible/On State Registry |
| <input type="checkbox"/> | <ul style="list-style-type: none"> • Designated by Historic Commission |
| <input type="checkbox"/> | Community Housing |

**TOWN OF WEST NEWBURY
COMMUNITY PRESERVATION COMMITTEE**

APPLICATION FOR PROJECT ELIGIBILITY

CPA ELIGIBILITY REQUIREMENTS				
	Open Space	Recreation	Historic	Housing
Acquire	Yes	Yes	Yes	Yes
Create	Yes	Yes	No	Yes
Preserve	Yes	Yes	Yes	Yes
Support	No	No	No	Yes
Rehabilitate and/or Restore	Yes, if acquired or created with CPA funds	Yes (New 7/8/2012)	Yes	Yes If acquired or created with CPA funds
Adapted from "Recent Developments in Municipal Law", Massachusetts Department of Revenue, October 2012				

General Criteria

The Community Preservation Committee will give preference to proposals which address as many of the following general criteria as possible:

- Are consistent with the planning documents that have received wide scrutiny, public input and have been adopted by the Town such as the Open Space and Recreation Plan, Capital Improvement Plan and Master Plan;
- Preserve and enhance the character of the town;
- Save resources that would otherwise be threatened;
- Serves a currently under-served population;
- Either serve more than one CPA purpose (especially in linking open space, recreation and community housing) or demonstrate why serving multiple needs is not feasible;
- Demonstrate practicality and feasibility; demonstrate that the project can be implemented expeditiously and within budget;
- Produce an advantageous cost/benefit value;
- Leverage additional public and/or private funds;
- Preserve or utilize current town-owned assets; and
- Receive endorsement by other municipal boards or departments as well as community groups.

**TOWN OF WEST NEWBURY
COMMUNITY PRESERVATION COMMITTEE**

APPLICATION FOR PROJECT ELIGIBILITY

PROJECT DESCRIPTION:

Provide a description of the project:

This project is for the design, engineering and permitting of a trail connecting recorded easements on the site of the recently-constructed Deer Run Subdivision (located off Main Street, generally across the street from Long Hill Orchard), across the Town’s newly-acquired Sawmill Brook Conservation Area (purchase of land closed on Dec. 15, 2024), and connecting to an existing trail located on the Mill Pond conservation area. Due to the presence of a wetlands system which includes a perennial stream, a portion of the trail is expected to require a boardwalk. The intent of the new trail will be to expand upon the existing passive recreational opportunities offered at the Town’s Mill Pond / Pipestave Hill Conservation Area, allowing for an expanded trail network and improved public access.

The geographic scope of the project will also include design, engineering and permitting to improve an existing location where a trail crosses wetlands. This location, located within the Poor House Lane right-of-way, north of where the constructed roadway ends, would benefit from design attention. Now that Sawmill Brook is publicly owned, it is anticipated that this access point (via the Poor House Lane ROW) will get more use, so it may need some type of boardwalk. This would be determined within the design phase of the work proposed for CPA funding.

The location of the work is generally illustrated on the attached map:

- The primary focus of the design/engineering/permitting work will be the proposed connection from Deer Run to Mill Pond, via Sawmill Brook (basically, to connect “Point A” to “Point B” on the map)
- The secondary focus of the design/engineering/permitting work will be the existing trail/wetlands crossing within the Poor House Lane ROW (generally, “Point C” on the map)

How is this project consistent with the goals of the CPA?

The acquisition of the Sawmill Brook property was partially funded with CPA funds (along with State LAND Grant funds, and contributions from Essex County Greenbelt). This proposed project will advance design/engineering/permitting in order to expand the trail network and improve public access. The trail will connect the popular Pipestave Hill / Mill Pond recreational area to recorded trail easement in the Deer Run development. The boardwalk design over Sawmill Brook and wetlands would ensure minimal impacts to the resource areas and provide for public viewing of wildlife and natural areas.

**TOWN OF WEST NEWBURY
COMMUNITY PRESERVATION COMMITTEE**

APPLICATION FOR PROJECT ELIGIBILITY

What is the intended timeline of the project?

- Initial Planning and Coordination with Town staff, boards, commissions, and committees – Winter 2024 (ongoing)
- Submit CPC Eligibility Application – January 2024
- Submit CPC Funding Application – February 2024
- Seek CPC Funding at Town Meeting – April 2024
- Finalize Scope and Seek Proposals for Design / Engineering / Permitting – Spring 2024
- Contract with Consulting Firm – Early summer 2024
- Preliminary Design and Permitting – Summer/Fall 2024 (Note: there are many variables in the design and, especially, permitting process, so this estimated timeline could change as the project moves forward)
- Seek funding for project construction (may include CPA funding proposal, State grant application, coordination of in-kind support, or some combination thereof) – Once project is fully permitted.

Subsequent to the work proposed here (and NOT part of the present CPA funding proposal), the Town would proceed with:

- Construction Documents out to Bid
- Construction Contract Signed
- Construction

FUNDING:

Estimated funding needed for this project:	\$ Unknown. (The Town is working to secure estimated costs for purposes of submitting a CPA funding application in February 2024).
CP funding requested:	\$ Full amount of design / engineering / permitting costs. (Note: Town staff do expect to invest significant time/effort toward this project as a non-financial in-kind match).

OTHER:

Please attach any other information which you think would be useful for the CPC to consider when evaluating this project’s eligibility for funding.

See attached maps (3) from the Sawmill Brook Conservation Area Acquisition Project, and one map generally illustrating the proposed locations where the design work would focus.

TOWN OF WEST NEWBURY
 COMMUNITY PRESERVATION COMMITTEE

APPLICATION FOR PROJECT ELIGIBILITY

Sawmill Brook Conservation Project
 32 acres +/-

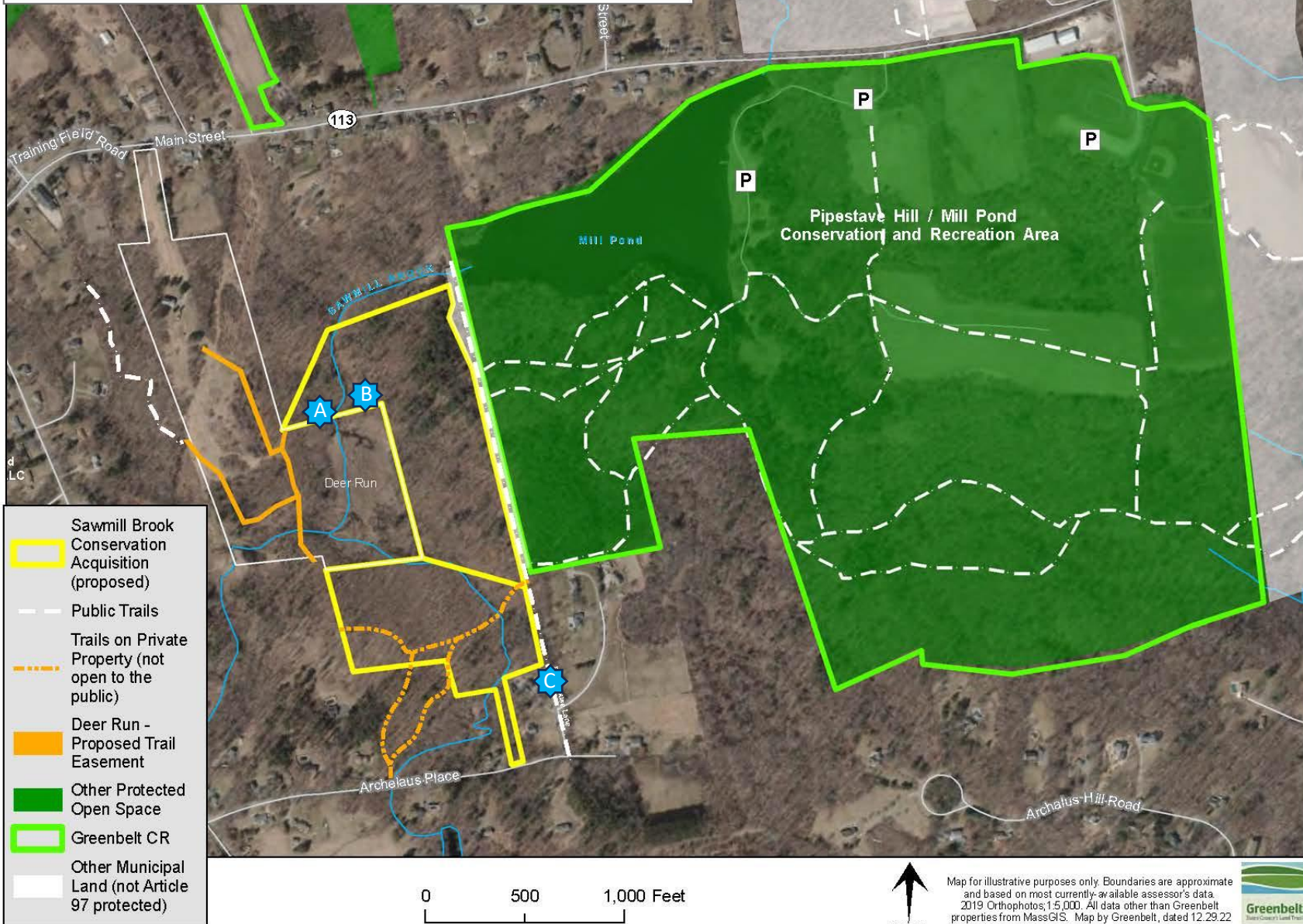

ARTICLE REQUEST FORM

ARTICLE: Quaker Cemetery Clean Up

AMOUNT REQUESTED: \$ 4,000

CONTACT PERSON: Bob Janes

PHONE NUMBER: 978-518-6391

Why should the Town make this purchase? What needs will be met? Who will benefit?

Removal of the tree is necessary to protect the integrity of the headstones as a historic resource.

What factors affect the timing of this purchase?

The tree is damaged and in danger of falling. Removal as soon as funding is approved is proposed.

When should this Article be sunsetted—how long will the project take?

Sunset date of June 30, 2025

What ancillary costs do you anticipate? (Maintenance, Insurance, Training, etc.)

Once the tree is removed using funding from this project, ongoing maintenance will be provided by the DPW.

Does this Article involve improvement, preservation or creation of tangible Town-owned assets and projects which 1) have useful life of at least five years; 2) cost over \$20,000 and or 3) for which the Town is authorized to borrow funds? If so, please confirm that this item is on the Capital Improvements Committee Schedule for future capital investments.

No

Please attach additional pages or other supporting documentation.

**TOWN OF WEST NEWBURY
COMMUNITY PRESERVATION COMMITTEE**

APPLICATION FOR PROJECT FUNDING

This application may be completed electronically and emailed to cpc@wnewbury.org or printed and completed by hand and submitted to the CPC Administrator. All applications must be received by the CPC Office at least 2 weeks prior to a scheduled meeting in order to be considered by the Committee. For more information contact 978-363-1100 X131.

APPLICANT INFORMATION

Project Name:	Quaker Cemetery Clean Up
Project Address:	Turkey Hill Road
Map/Lot:	R- 20
Applicant Name: (Group or Committee Affiliation)	Historic Commission
Contact Person:	Robert Janes
Telephone:	978-518-6391
Address:	P.O. Box 214 West Newbury, Mass. 01985
Email:	Icepick185@gmail.com
Date of Application:	16 January 2024

PROJECT ELIGIBILITY

Community Preservation Category(ies)	
Date Approved by CPC	

**TOWN OF WEST NEWBURY
COMMUNITY PRESERVATION COMMITTEE**

APPLICATION FOR PROJECT FUNDING

PROJECT NARRATIVE

Provide information for the following project components, providing attachments where necessary which clearly reference the heading. All project components listed must be addressed in order for the project to be considered by the CPC.

PROJECT SUMMARY - Provide a description of the Project, including the property involved and its proposed use.

The Historic Commission used CPA funds last year (2023) to remove brush, poison ivy, and fallen branches in the Quaker Cemetery. That project has been completed. There is one large maple tree that should be removed and dead branches in other trees that should be removed to prevent more damage to the head stones.

PUBLIC BENEFIT—Describe in detail the benefits West Newbury will receive from the Project and how the Project meets the Community Preservation Committee’s Project Evaluation Criteria.

It will demonstrate that West Newbury takes pride in maintaining abandoned burying grounds within town limits.

CONTROL OF SITE - Indicate whether the applicant owns or has a purchase agreement for the Project site. If the property is under agreement, include a description of the agreement and the timing and conditions of the purchase. If the applicant does not have site control, explain how the project will go forward.

This property is already owned by, or is under control of, the Town of West Newbury. The 2023 annual Town Meeting appropriated CPA funds to cleanup and maintain the site.

**TOWN OF WEST NEWBURY
COMMUNITY PRESERVATION COMMITTEE**

APPLICATION FOR PROJECT FUNDING

FEASIBILITY - List all steps that may be required for completion of the Project, such as environmental assessment, zoning or other approvals, agreement on terms of any required conservation, affordability or historic preservation restrictions, and any other known issues. For projects that may affect abutters or the neighborhood, describe methods used to notify abutters of the proposal, and support or objections from those affected.

N/A

SUPPORT—Seek input from relevant Town entities and members of the community. Provide documentation of their response.

The Conservation Commission has approved the work at the site.

SCOPE OF WORK —A scope of work is required to fully develop a time and cost plan for recommendation to Town Meeting. The scope is to be prepared by the Applicant and be detailed enough, in the opinion of the CPC, that a professional qualified to perform the work will be able to provide an estimate of the time and cost necessary to complete the proposed work. Attach the scope of work to this application.

The scope of work is to remove a tree and some limbs that may cause further damage to the grave stones.

**TOWN OF WEST NEWBURY
COMMUNITY PRESERVATION COMMITTEE**

APPLICATION FOR PROJECT FUNDING

PROJECT TIMELINE - Describe the anticipated steps or phases for completion of the Project. State whether the Project will be ready to proceed in the coming fiscal year. Will this be a multi-year project?

We anticipate the removal of one tree and some dead branches. No more than 5 days. After that it will be a yearly clean up.

FUNDING - Include a full budget, including itemization of major components and breakdown of construction costs. Describe The estimated annual cost of operating and maintaining the site/project after completion. Describe the basis for your budget and the sources of information you used.

As of November 2023

OTHER - Please provide any other information which you think would be useful for the CPC to consider when evaluating this project's eligibility for funding (attach additional pages if needed):

**TOWN OF WEST NEWBURY
COMMUNITY PRESERVATION COMMITTEE**

APPLICATION FOR PROJECT FUNDING

APPLICATION CHECKLIST:

To be completed by Applicant and approved by CPC Administrator prior to the application being reviewed by the CPC.

Y	N/A	Application Requirement
		Proof of ownership or control of the site, structure, or subject of Application.
	**	Proof of authorization by the public agency, board, committee, or any entity governed by a board, trustees, corporation etc., showing a vote by the entity to submit the applications and to take responsibility for the project.
X		If the project involves public property, verification that the applicable public agency or department supports the project as presented.
X		Assessor's map showing location of the Project.
X		Photographs, including aerial photographs if available.
X		Detailed scope of work for the project prepared by the Applicant.
X		Recent cost and time to complete estimates from professionals qualified to complete the project.
		Proposed oversight and management plan for the Project.
	N/A	If the project involves a historic resource, evidence (date of listing on the state register or a letter from the West Newbury Historical Commission confirming its determination of significance) with the application that it meets these criteria.
	N/A	Architectural plans and specifications, for new construction or rehabilitation.
x		Maps, renderings, site plans.
	N/A	Historic structures report, existing conditions report.
X		Names and addresses of project architects, contractors and consultants.
		Documentation of support from Town entities and Community.
X		Permission from the property owner to display a CPC funded project sign.

Reviewed by CPC Administrator:

Signature	
Date	

**** SEE PAGE #3 ITEM #2**

ARTICLE REQUEST FORM

ARTICLE: Extend sunset date for prior Town Meeting articles
AMOUNT REQUESTED: n/a
CONTACT PERSON: Angus Jennings, Town Manager
PHONE NUMBER: 978-363-1100 ext. 115

Why should the Town make this purchase? What needs will be met? Who will benefit?

The following is a list of articles that were approved at prior Town Meetings including sunset dates of June 30, 2024. The projects/initiatives that this funding supports are ongoing, and the funding either will not, or may not, be expended or obligated (i.e. under contract) by that date. This is a proposal to extend the sunset dates as detailed below, to preserve the availability of these previous allocations to support the projects as the move toward completion.

Article	Project	Current		Sunset date	Proposed sunset date	Rationale
		Beg. Balance (7/1/23)	balance (2/1/24)			
ATM 52221 A16	Middle St. Bridge	\$ 600,000	\$ 600,000	6/30/2024	6/30/2027	Extension to match eligible timing to utilize at least \$1.5M in awarded grants
STM 51422 A3	S&S Mem. Bldg.	\$ 26,688	\$ 26,688	6/30/2024	None	Preserve availability of funding to pursue disposition and historical preservation restriction
ATM 51422 A18	Telecom systems	\$ 65,000	\$ 65,000	6/30/2024	6/30/2025	Project underway. Likely under contract by 6/30/24 but proposed extra time if needed
STM 51422 A6	Facility Improvements	\$ 36,902	\$ 21,429	6/30/2024	6/30/2025	Several funded projects complete; others ongoing
ATM 51422 A14	Relocate Facilities/DPW workstation	\$ 35,900	\$ 35,900	6/30/2024	6/30/2025	Project at scoping phase to fully optimize Facilities & Highway DPW Divisions

What factors affect the timing of this purchase?

Unless extended by vote of Town Meeting, the funding for the listed projects may (and in some cases) will expire and be turned back to Free Cash after June 30, 2024. The listed projects/initiatives continue to be underway and important priorities of the Select Board and Town Manager. The proposed extension of sunset dates will preserve the availability of these previously-allocated funds to advance these projects to completion.

When should this Article be sunsetted - how long will the project take?

Proposed extension of sunset dates detailed above.

What ancillary costs do you anticipate? (Maintenance, Insurance, Training, etc.)

None

Does this Article involve improvement, preservation or creation of tangible Town-owned assets and projects which 1) have useful life of at least five years; 2) cost over \$20,000 and or 3) for which the Town is authorized to borrow funds? If so, please confirm that this item is on the Capital Improvements Committee Schedule for future capital investments.

Some articles proposed for sunset extension were considered and recommended as Capital articles at previous Town Meetings, but this article does not create any new capital articles or funding requests.

Please attach additional pages or other supporting documentation.

ATM 52221 A16 Middle Street Bridge

ARTICLE 16 The Finance Committee recommended approval of this Article.

Select Board Member Wendy Reed moved that the Town vote to transfer from the Capital Stabilization Fund the sum of \$600,000 for costs and expenses pertaining to the Town's share for the reconstruction of the Middle Street Bridge, Any remaining funds will be closed out to the Capital Stabilization Fund at the close of Fiscal Year 2024.

Since this was an expenditure from a Stabilization Account, the Moderator declared that a two thirds vote was necessary for passage.

The Moderator declared that the Tellers would take a hand count. The hand court was 125 in favor and 24 opposed. The Moderator declared that the Motion passed.

STM 51422 A3 Soldiers & Sailors Memorial Building

ARTICLE 3.

The Finance Committee made no recommendation.

Select Board member Richard Parker moved that the Town authorize the disposition, by sale or lease, of the Soldiers and Sailors Memorial Building, located on Assessors' parcel R10-34, located at 363 Main Street, subject to procurement requirements, subject to a Historic Preservation Restriction, and in anticipation of proposing a zoning amendment at a future Town Meeting to expand the allowable uses in this location, and to transfer from Free Cash the sum of \$28,000 to fund costs associated with the preparation of such Historic Preservation Restriction and costs associated with disposition, with any remaining funds to be closed out to the general account fund balance at the close of Fiscal Year 2024.

The motion was seconded by Select Board member David Archibald.

With there being no discussion, the Town Moderator called for a vote, and declared that the Motion carried.

ATM 51422 A18 Telecom systems

ARTICLE 18.

The Finance Committee recommended approval of this Article 4-1-0.

Select Board member Richard Parker moved that the Town vote to transfer from the Capital Stabilization Fund the sum of \$65,000 for all costs and expenses pertaining to the replacement of the Town Offices telecommunications system, with any remaining funds to be closed out to the Capital Stabilization Fund at the close of Fiscal Year 2024.

The motion was seconded by Select Board member David Archibald.

The Town Moderator stated that, because this was a request for authorization of stabilization funding, passage of the article requires a 2/3 vote. With there being no discussion, the Town Moderator called for a vote and declared that the Motion carried with a clear 2/3 majority with 1 person in opposition.

STM 51422 A6 Facility Improvements

ARTICLE 6.

The Finance Committee made no recommendation on the full article.

Select Board member Richard Parker moved that the Town transfer from Free Cash the sum of \$47,845 to fund several facility improvements throughout the town, with any remaining funds to be closed out to the general account fund balance at the close of Fiscal Year 2024.

The motion was seconded by Select Board member David Archibald.

With there being no discussion, the Town Moderator called for a vote, and declared that the Motion carried.

ATM 51422 A14 Relocate Facilities/DPW workstation

ARTICLE 14.

The Finance Committee recommended approval of this Article 5-0-0.

Select Board member Richard Parker moved that the Town vote to transfer from Free Cash the sum of \$25,000 to fund an evaluation/audit of the brick exterior/lintels of the Page School, with any remaining funds to be closed out to Free Cash at the close of Fiscal Year 2024.

The motion was seconded by Select Board member David Archibald.

With there being no discussion, the Town Moderator called for a vote and declared that the Motion carried unanimously.

ARTICLE REQUEST FORM

ARTICLE: Fire Department Tanker Replacement

AMOUNT REQUESTED: \$560,000

CONTACT PERSON: Board of Fire Engineers

PHONE NUMBER: 978-363-1111

Why should the Town make this purchase? What needs will be met? Who will benefit?

The Board of Engineers is requesting funding to replace and equip a 1984 Ford Tanker. The tanker is used to transport 3,000 gallons of water to support firefighting operations. Tankers are specialized vehicles that are common to rural fire departments. This vehicle is especially important when responding to emergencies in the areas of town that do not have municipal water. Firefighters will benefit from a new, safe and reliable vehicle to be used for emergency response.

What factors affect the timing of this purchase?

This vehicle was purchased new in 1984 and refurbished in the late 1990's to replace the water tank and body. Throughout its long life, the front mounted water pump has been rebuilt several times to replace seals, valves, and other costly repairs. Beginning in 2017 the board began researching grants to fund the replacement of this vehicle. We applied several times for the FEMA Assistance to Firefighter Grant - Apparatus Replacement Program and were denied. During this time the vehicle continued to pass NFPA compliant pump testing and remained in service. As a board, we agreed to delay capital replacement because it continued to be well maintained and remained operational. Over the last 2-years the tanker has no longer passed its required testing and annual preventative maintenance indicates it is due for replacement.

When should this Article be sunsetted - how long will the project take?

6/30/2024

What ancillary costs do you anticipate? (Maintenance, Insurance, Training, etc.)

Does this Article involve improvement, preservation or creation of tangible Town-owned assets and projects which 1) have useful life of at least five years; 2) cost over \$20,000 and or 3) for which the Town is authorized to borrow funds? If so, please confirm that this item is on the Capital Improvements Committee Schedule for future capital investments.

Please attach additional pages or other supporting documentation



1984 Ford 3,000 gallon tanker



Example of EOne 3,000 gallon tanker

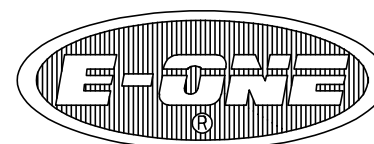
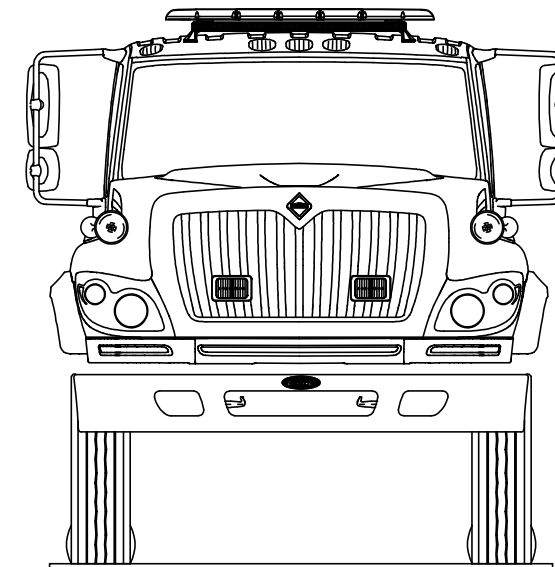
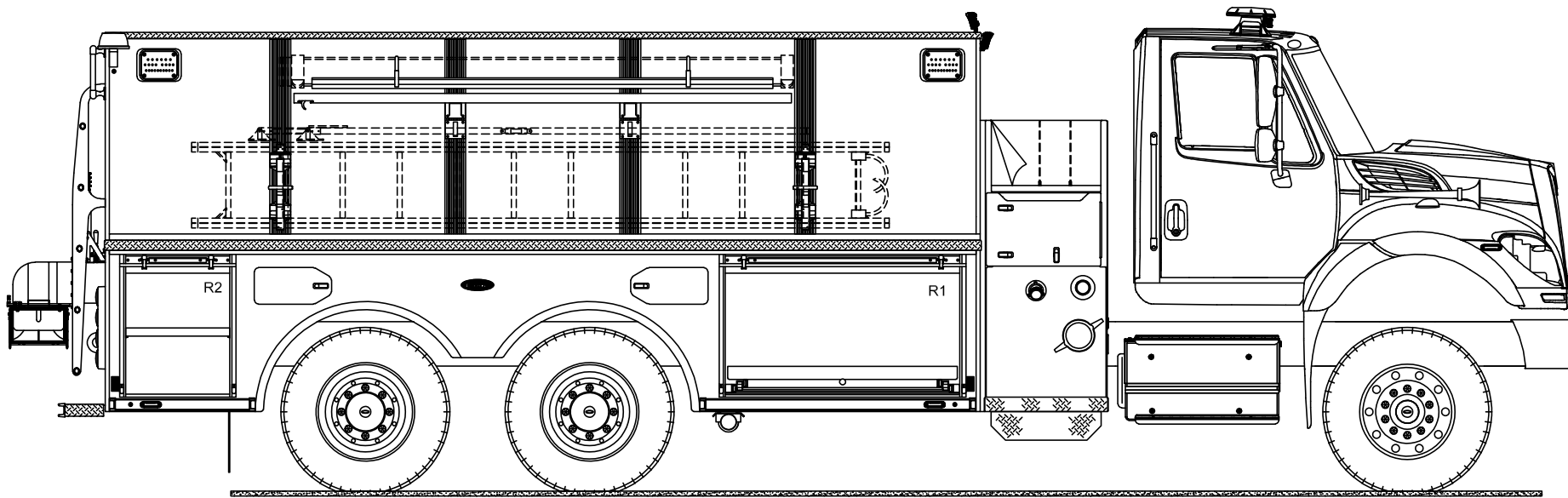

GREENWOOD EMERGENCY VEHICLES LLC

NORTH ATTLEBORO, MA
 SO.146628 / Q124099
 COMMERCIAL TANKER
 1250 GPM HALE DSD PUMP
 3000 GAL WATER

INTERNATIONAL HV607 2 DOOR CAB 6X4 CHASSIS

SIDE MOUNT TANKER					
COMPT.	OPENING		INTERIOR DIMENSION		
L1/R1	57.5W	30H	60W	37.75H	26D
L2/R2	26.5W	30H	28W	37.75H	26D

THIS DRAWING IS FOR REFERENCE PURPOSES. ALL DIMENSIONS ARE SUBJECT TO MINOR VARIATIONS DUE TO MANUFACTURING PROCESSES.

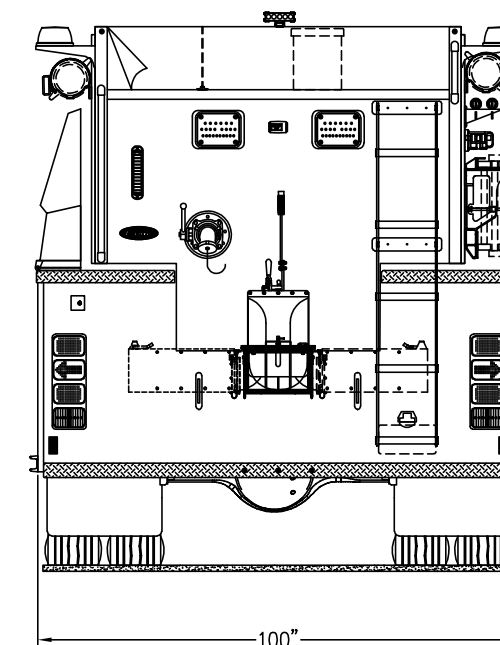
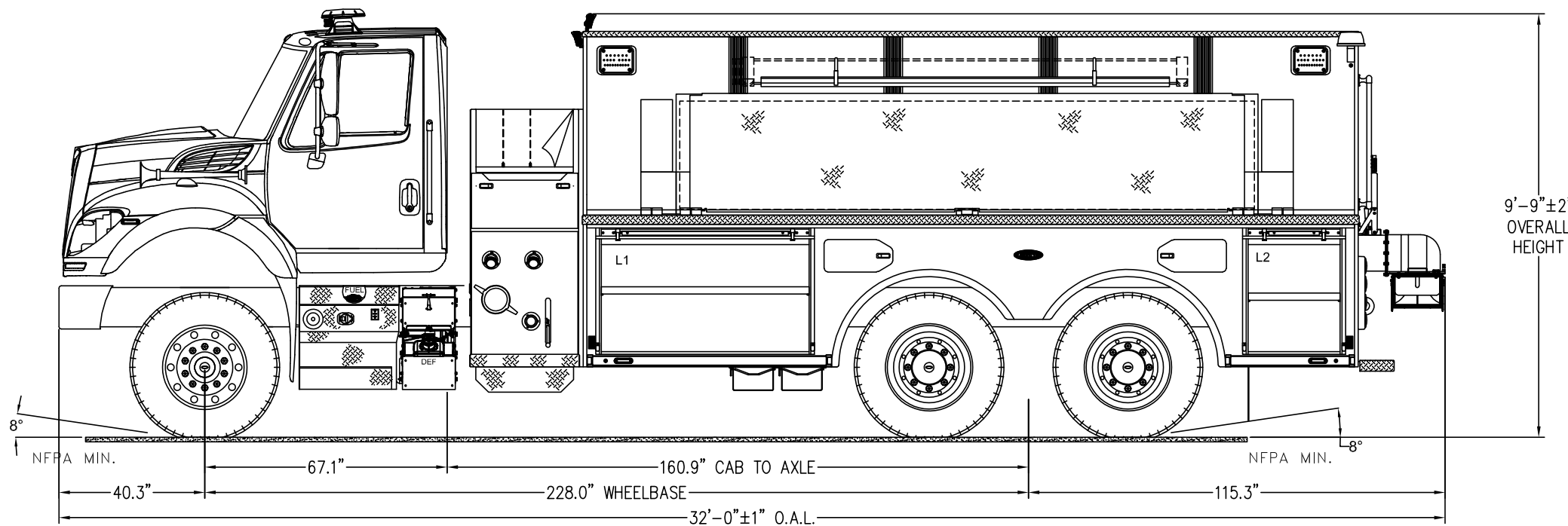

Tanker 25 Equipment Needs

Hose Adapters (for attaching different sizes and types)

- 4½” male to 6” female
- 5” male to 6” female
- 4” storz to 2½” male
- 4” storz to 2½” female
- 4” storz to 4½” female
- 4” storz to 4½” male
- 2 ½” double male
- 2 ½” double female
- 1 ½” male NPSH to 1 ½” female NH
- 1 ½” female NPSH to 1 ½” male NH
- 1 ½” double male
- 1 ½” double female
- 1” NH male to 1” NPSH female
- 1” NH female to 1” NPSH male
- 1” NPSH male to 1” NH female
- 1” NPSH female to 1” NH male
- 1 ½” NPSH female to 1” NH male
- 1” Mass Forestry female to 1” NH male
- 1” Mass Forestry male to 1” NH female
- 1 ½” NPSH to 1” Mass Forestry

Drafting Equipment (for using water from ponds/reservoir)

- (1) 6” Low profile strainers
- (1) 6” floating strainer

Hand Tools

- (1) 8’ pike pole
- (1) 8’ NY hook
- (1) Halligan
- (1) flathead axe

Handline Nozzles

- (1) 1¾” smoothbore nozzle
- (2) 1¾” combination nozzle
- (2) 2½” smoothbore nozzles

Fire Hose

- 200’ 2½” (preconnect)

- 600' 2½" hose (extra in hosebed)
- 1000' 4" (supply line in hosebed)
- (2) 25' 4" (short length for boosting pressure at a hydrant)

Appliances for Tanker Operations

- (1) 3,500 Gallon portable dump tank (used to store water on scene for fire operations)
- (1) 2 ½ -1¾" gated wye (allows use of two smaller handlines from one large line)
- (1) 4" clappered wye (used to create an uninterrupted water supply from tankers)
- (1) 1¾" jet siphon 6" (used to move water from one dump tank to another during extensive/extended water supply operations)
- (1) Hydrant Assist Valve (attached to hydrant to get water and boost pressure)
- (1) Jaffrey valve (for truck water intake valve)

Miscellaneous Equipment

- (2) Handheld flashlights with chargers
- (1) Dry chemical fire extinguisher
- (2) Truck radios VHF and UHF (fire and police radios)

Town of West Newbury Capital Improvement Program - Project Request summary

CIP CODE FD-003



Date: 12/27/2019, updated 10/3/23 Dept. Priority (1 of 3, etc.): 1
 Department: Fire Department Est. Funding Request: \$550,000
 Project Title: 3,000 Gallon Water Tanker Truck Replacement (E25) Est. Useful Life (Years): 20 - 25 YEARS
 Contact: Michael Dwyer, FIRE CHIEF
 Previously Presented? Yes No If Yes, when? (FY): _____

Project Type: Check All That Apply -

Scheduled Replacement	<input checked="" type="checkbox"/>	Expanded Service	<input type="checkbox"/>	Deemed Critical by Dept.	<input checked="" type="checkbox"/>
Present Equipment Obsolete	<input checked="" type="checkbox"/>	New Operation	<input type="checkbox"/>	Regulatory Requirement	<input type="checkbox"/>
Replace Worn-out Equipment	<input checked="" type="checkbox"/>	Improved Efficiency/Procedures	<input checked="" type="checkbox"/>	Other	<input type="checkbox"/>
Health and Life Safety	<input checked="" type="checkbox"/>	New Revenue	<input type="checkbox"/>		

Project Description:
 Request to replace a 1989 L8000 Ford custom 3,000 gallon water tanker/pumper with a new 3,000 gallon tanker/pumper. This vehicle will meet NFPA standards and ratings for fire apparatus design and safety. The current vehicle is beyond the NFPA standards for in-service use (25y) and does not meet current safety standards. We have applied several times for grants to replace this vehicle. These FEMA grants are highly competitive national grants that we have been denied as a result of financial need. We are considering applying for this grant in 2020. The project will include costs associated with engineering and construction visits, and training.



Project Financing:
 Total Project Cost: _____ \$550,000 Stabilization Funding: _____ \$0
 Amount & Type of Other Local Funding (ie. CPC, bond, op. budget): _____ \$0 Comments: _____
 Amount and Type of Non-Local Funding Sources (ie. Grant): _____ \$0 Comments: _____

Future Costs & Operating Expenses:
 Estimated Annual Cost of Operation & Maintenance _____ \$0 Comments: _____
 Estimated Net Effect on Operating Cost, Revenues, Staffing? _____ \$0 Comments: _____

Project Planning:
 Proposed Start Date of Project: unknown
 How was estimated cost determined? Estimated
 Is Funding Necessary for Further Plans/Estimating? _____
 Can the Project be Phased? If yes, expenditure by year _____

	FY21	FY22	FY23	FY24	FY25	FY26	FY27	FY28	FY29	FY30+	TOTAL
PROPOSED	\$	\$	\$	\$	\$550,000	\$	\$	\$	\$	\$	\$550,000
CIC RECC.	\$	\$	\$	\$	\$	\$	\$	\$	\$	\$	\$
APPROVED	\$	\$	\$	\$	\$	\$	\$	\$	\$	\$	\$

ARTICLE REQUEST FORM

ARTICLE: Advance warning detection and signage for streets approaching Rocks Village Bridge

AMOUNT REQUESTED: TBD (Awaiting estimate from prospective vendor, for budgeting purposes)

CONTACT PERSON: Angus Jennings, Town Manager

PHONE NUMBER: 978-363-1100 ext. 115

Why should the Town make this purchase? What needs will be met? Who will benefit?

The Rocks Village Bridge has been struck by overheight vehicles on several occasions in recent years. The resulting damage to the bridge has resulted in the bridge being out of service for extended periods of time. The Town has worked closely with MassDOT and the City of Haverhill toward completion (in the past year) of a significant increase in signage and roadway striping as part of a regional attempt to increase adherence to the height restriction.

Nevertheless, we fear that it is inevitable that the bridge will be struck again by an overheight vehicle. In 2022-23, MassDOT proposed installation of an overheight sign on Bridge Street, but the Select Board favored an alternative method of advance driver notice. The system envisioned would include dual-beam overheight sensors with associated advance warning alerts, installed on up to three streets approaching the RVB (Bridge Street, River Road, Church Street). Specific system design will be subject to review and approval of the Select Board as the Town's Roadway Commissioners.

What factors affect the timing of this purchase?

The sooner a system such as envisioned is installed, the greater preventative measure against potential future bridge strikes by overheight vehicles.

When should this Article be sunsetted - how long will the project take?

FY25

What ancillary costs do you anticipate? (Maintenance, Insurance, Training, etc.)

May result in modest incremental costs for maintenance, insurance and training.

Does this Article involve improvement, preservation or creation of tangible Town-owned assets and projects which 1) have useful life of at least five years; 2) cost over \$20,000 and or 3) for which the Town is authorized to borrow funds? If so, please confirm that this item is on the Capital Improvements Committee Schedule for future capital investments.

Yes

Please attach additional pages or other supporting documentation.

Town of West Newbury Capital Improvement Program - Project Request summary CIP CODE DPW-043



Date: 4-Feb-24 **Dept. Priority (1 of 3, etc.):** 1
Department: DPW **Est. Funding Request:** \$65,000
Project Title: Advance warning detection system and signals for Rocks Village Bridge **Est. Useful Life (Years):** years
Contact: Angus Jennings, Town Manager
Previously Presented? Yes No **If Yes, when? (FY):**

Project Type: Check All That Apply -

Scheduled Replacement	<input type="checkbox"/>	Expanded Service	<input checked="" type="checkbox"/>	Deemed Critical by Dept.	<input checked="" type="checkbox"/>
Present Equipment Obsolete	<input type="checkbox"/>	New Operation	<input checked="" type="checkbox"/>	Regulatory Requirement	<input type="checkbox"/>
Replace Worn-out Equipment	<input type="checkbox"/>	Improved Efficiency/Procedures	<input checked="" type="checkbox"/>	Other	<input type="checkbox"/>
Health and Life Safety	<input checked="" type="checkbox"/>	New Revenue	<input checked="" type="checkbox"/>		

Project Description:

The Rocks Village Bridge has been struck by overheight vehicles on several occasions in recent years. The resulting damage to the bridge has resulted in the bridge being out of service for extended periods of time. The Town has worked closely with MassDOT and the City of Haverhill toward completion (in the past year) of a significant increase in signage and roadway striping as part of a regional attempt to increase adherence to the height restriction.

Nevertheless, we fear that it is inevitable that the bridge will be struck again by an overheight vehicle. In 2022-23, MassDOT proposed installation of an overheight sign on Bridge Street, but the Select Board favored an alternative method of advance driver notice. The system envisioned would include dual-beam overheight sensors with associated advance warning alerts, installed on up to three streets approaching the RVB (Bridge Street, River Road, Church Street). Specific system design will be subject to review and approval of the Select Board as the Town's Roadway Commissioners.



Project Financing:

Total Project Cost:	\$65,000	Stabilization Funding:	\$0
Amount & Type of Other Local Funding (ie. CPC, bond, op. budget):	\$0	Comments:	
Amount and Type of Non-Local Funding Sources (ie. Grant):	\$0	Comments:	

Future Costs & Operating Expenses:

Estimated Annual Cost of Operation & Maintenance	\$0	Comments:	
Estimated Net Effect on Operating Cost, Revenues, Staffing?	\$0	Comments:	

Project Planning:

Proposed Start Date of Project: **Summer 2024**

How was estimated cost determined? **Estimated. Expect to have proposed budgetary cost in February 2024.**

Is Funding Necessary for Further Plans/Estimating?

Can the Project be Phased? If yes, expenditure by year

	FY21	FY22	FY23	FY24	FY25	FY26	FY27	FY28	FY29	FY30+	TOTAL
PROPOSED	\$	\$	\$	\$	\$65,000	\$	\$	\$	\$	\$0	\$65,000
CIC RECC.	\$	\$	\$	\$	\$	\$	\$	\$	\$	\$	\$
APPROVED	\$	\$	\$	\$	\$	\$	\$	\$	\$	\$	\$

Georgia County Significantly Reduces Overheight Trestle Bridge Collisions



CUSTOMER NAME

Athens-Clarke County, GA

PRODUCTS

[Overheight Warning System](#)

SUMMARY

The City of Athens-Clarke County knew it needed an overheight safety solution due to an increasing number of major strikes occurring at a low-clearance railroad trestle bridge, with one especially harmful collision causing a railroad derailment.

ORGANIZATION

Located roughly 70 miles northeast of Atlanta, Athens-Clarke County is a consolidated city-county in the state of Georgia. It is home to roughly 127,000 residents, many of which are students at the local University of Georgia.

SITUATION

A railroad trestle bridge on a two-lane road had been the site of major overheight strikes for many years in Athens-Clarke County, Georgia. The city suspected the problem was amplified by heavy commercial traffic coming from a major freeway north of town, with significant student traffic from the University of Georgia adding to the mix. The presence of a concrete plant just beyond the trestle bridge meant dump trucks were constantly passing through as well.

The damage from overheight collisions can be costly, often reaching \$200,000 to \$300,000 or more, according to a [Texas Department of Transportation Study](#). Constant repairs and collisions were taking their toll on the city, with loss of life becoming a serious concern as well.

“There’s been substantial damage to the trucks and vehicles that come under there,” remarked George Spearing, Athens-Clarke County Signal Systems Engineer. “They’re getting major strikes where they’re stuck under the bridge or ripping the top off their vehicle. I don’t recall that anyone was seriously injured but... somebody really hitting it hard and having a serious injury was not far out from happening.”

A dangerous train derailment caused by a collision at the trestle bridge pushed city officials to consider new solutions, realizing that their existing static signage about clearance heights was insufficient. In addition, the city needed a way to be alerted when bridge strikes did happen.

After all, had the city been notified of the overheight accident immediately when it happened, officials could have proactively warned the railroad company to stop the train from passing over the damaged bridge. This would reduce both risk of injury and use of resources.

***It costs
roughly
\$200,000
to
\$300,000
every time
a vehicle
collides
with a
bridge.***

According to a [Texas Department of Transportation Study](#)

Athens knew it needed an innovative solution that would provide this type of notification capability and reduce overheight collisions — and it couldn't wait another moment. An average of eight strikes were reported yearly, with many more going unreported due to drivers leaving the scene.

SOLUTION

Athens-Clarke County officials turned to TAPCO when they began investigating overheight warning systems, prompted by their satisfaction with the [TAPCO RRFB Pedestrian Crosswalk Systems](#) they had already installed.

“We’ve got a lot of TAPCO RRFBs, so we’ve had a pretty good relationship with TAPCO for a number of years,” explained George. “It’s the customer service and the history that we’ve got with them that made us go with TAPCO.”

The system uses infrared sensors mounted in advance of low structures, which detect overheight vehicles at a user-configurable height and determine their direction of travel. Flashing alerts – either LED-enhanced signs called BlinkerSigns or LED beacons called BlinkerBeacons – are triggered when an overheight vehicle is detected, notifying them of the height restriction and directing them to an alternate route.

Both types of alerts were installed for Athens-Clarke County, providing them with high-intensity, eye-catching signage. These alerts can be AC or solar powered, with Athens-Clarke County officials opting to install both. They placed AC-powered alerts near large oak trees casting significant shadows and solar-powered alerts in sunny spots.

A subscription to TAPCO's event management software, BlinkLink®, was also selected by Athens-Clarke County. With this software, Athens-Clarke County gained the ability to remotely program the system, generate high-priority alerts to pre-selected recipients, compile actionable data and get system diagnostics from any web-enabled device.

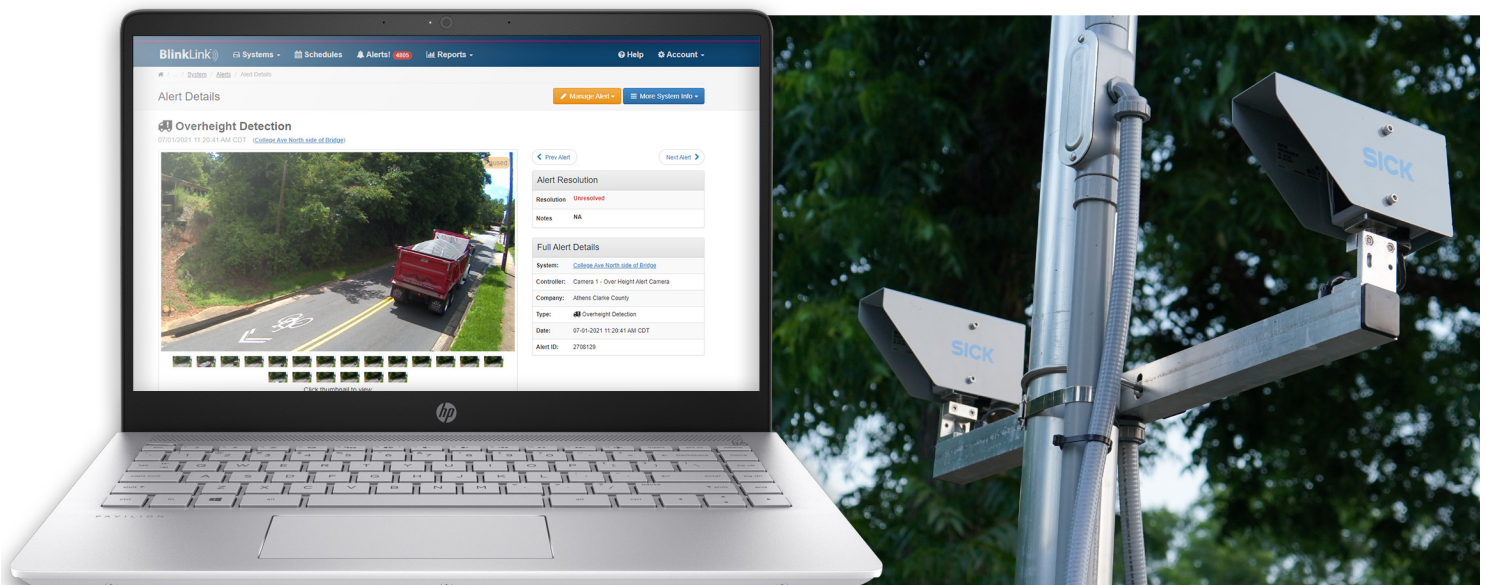

Most of the installation was done in-house by Athens-Clarke County, with a local crew constructing all the necessary foundations and bases before the wiring was installed. It was during installation that city workers saw the clear need for the system play out in front of them.

“We actually had two strikes happen in the same day while we were out there installing this system,” recalled Rodney Rogers, Athens-Clarke County Traffic Signal Supervisor. “We had a dump truck come through and have his top cover torn off, and then another box truck came under and he actually got stuck. He got completely wedged under there while we were there.”

It was a sobering reminder for city employees that the TAPCO Overheight Warning System they were installing was long overdue and couldn’t have come a moment too soon.

RESULTS

Since the installation of the TAPCO Overheight Warning System, Athens-Clarke County has not identified a single collision at the trestle bridge. The system continues to activate when it is triggered by an overheight vehicle, providing imagery and notifications to the city, as well as video of the event thanks to BlinkLink®.

“It’s pretty simple,” remarked George. “It’s easy to install...it seems to be reliable. We’ve been happy with it.”

**“It’s
easy to
install...
it seems
to be
reliable.
We’ve
been
happy
with it.”**

*George Spearing, Athens-Clarke
County Signal Systems Engineer*



This steep drop in major incidents is significant given the heavy traffic at the two-lane road due to the nearby concrete plant and university. The system continues to provide prompt alerts via flashing LEDs, checked often by Rodney.

"About once a week, I drive my truck on both sides and double check that it's actually coming on... So far, every day it's come on and done what it's supposed to do," he said.

The dramatic decrease in collisions means not only saved money and resources for Athens-Clarke County, but a lessened fear that a collision could one day take a life.

***"Every day,
[the system
has] come on
and done what
it's supposed
to do."***

*Rodney Rogers, Athens-Clarke
County Traffic Signal Supervisor*



**Learn more about the TAPCO
Overheight Warning System here.**

ABOUT TAPCO

As an industry-leading innovator, TAPCO manufactures, services and distributes a wide portfolio of traffic and parking safety solutions designed to increase safe travels for all. Since 1956, we have set the standard for delivering reliable, cutting-edge traffic safety enhancements. From our world-renowned line of LED-enhanced BlinkerSign® solutions to our pedestrian crossing products and early detection warning systems, safety is at the heart of all TAPCO innovations.

Working alongside traffic professionals for more than 60 years- gives our team an exclusive perspective on the past, present and future needs of the traffic and parking safety industry.



Town of West Newbury
2024 Spring Town Meeting (FY25)

24

ARTICLE REQUEST FORM

ARTICLE: *Funding to replace the Annex flooring.*

AMOUNT REQUESTED: \$49,200 (Capital Request)

CONTACT PERSON: Brian Richard, Facilities Manager

PHONE NUMBER: 978-914-2546

Why should the Town make this purchase? What needs will be met? Who will benefit?

The Department of Public Works is looking to remove and replace the existing flooring the Annex. This project includes fixing the existing sewerage pipe, asbestos removal and removal and installation of new carpet tiles.

What factors affect the timing of this purchase?

When should this Article be sunsetted - how long will the project take?

Recommended sunset date of June 30, 2026

What ancillary costs do you anticipate? (Maintenance, Insurance, Training, etc.)

No additional cost anticipated.

Does this Article involve improvement, preservation or creation of tangible Town-owned assets and projects which 1) have useful life of at least five years; 2) cost over \$20,000 and or 3) for which the Town is authorized to borrow funds? If so, please confirm that this item is on the Capital Improvements Committee Schedule for future capital investments.

This article is a free cash request and meets the criteria for a Capital project. (DPW-041)

Please attach additional pages or other supporting documentation.

Town of West Newbury
2024 Spring Town Meeting (FY25)

25

ARTICLE REQUEST FORM

ARTICLE: *Replacement of Council on Aging A/C Unit*

AMOUNT REQUESTED: \$38,000 (Capital Request)

CONTACT PERSON: Brian Richard, Facilities Manager

PHONE NUMBER: 978-914-2546

Why should the Town make this purchase? What needs will be met? Who will benefit?

The Council on Aging currently has an A/C unit that is 15 years old and ready for replacement. This project will include removing the existing 15 year old York 7.5ton unit and replacing with a New Carrier 10-ton unit. Existing electrical and duct work will be used.

What factors affect the timing of this purchase?

The lifespan of the current York unit is approximately 10-15 years. This unit is starting to exceed its useful life and replacement is needed to avoid costly repairs.

When should this Article be sunsetted - how long will the project take?

Recommended sunset date of June 30, 2026

What ancillary costs do you anticipate? (Maintenance, Insurance, Training, etc.)

\$500 - \$1,000 annual maintenance.

Does this Article involve improvement, preservation or creation of tangible Town-owned assets and projects which 1) have useful life of at least five years; 2) cost over \$20,000 and or 3) for which the Town is authorized to borrow funds? If so, please confirm that this item is on the Capital Improvements Committee Schedule for future capital investments.

This article is a free cash request and meets the criteria for a Capital project but is not on the Capital Improvement Program list.

Please attach additional pages or other supporting documentation.

Town of West Newbury Capital Improvement Program - Project Request summary

CIP CODE COA-002



Date: 2-Feb-24 **Dept. Priority (1 of 3, etc.):** 1
Department: Council on Aging **Est. Funding Request:** \$38,000
Project Title: Replace A/C Unit in Council on Aging / SAGE Center **Est. Useful Life (Years):** 15 years
Contact: Brian Richard, Facilities Manager

Previously Presented? Yes No **If Yes, when? (FY):**

Project Type: Check All That Apply -

Scheduled Replacement	<input type="checkbox"/>	Expanded Service	<input type="checkbox"/>	Deemed Critical by Dept.	<input checked="" type="checkbox"/>
Present Equipment Obsolete	<input checked="" type="checkbox"/>	New Operation	<input type="checkbox"/>	Regulatory Requirement	<input type="checkbox"/>
Replace Worn-out Equipment	<input checked="" type="checkbox"/>	Improved Efficiency/Procedures	<input type="checkbox"/>	Other	<input type="checkbox"/>
Health and Life Safety	<input checked="" type="checkbox"/>	New Revenue	<input type="checkbox"/>		

Project Description: **Photo (click image to insert):**

The Council on Aging currently has an A/C unit that is 15 years old and ready for replacement. This project will include removing the existing York 7.5 ton unit and replacing it with a new Carrier 10-ton unit. Existing electrical and duct work will be used.

Project Financing:

Total Project Cost:	\$38,000	Stabilization Funding:	\$0
Amount & Type of Other Local Funding (ie. CPC, bond, op. budget):	\$0	Comments:	
Amount and Type of Non-Local Funding Sources (ie. Grant):	\$0	Comments:	

Future Costs & Operating Expenses:

Estimated Annual Cost of Operation & Maintenance	\$0	Comments:	
Estimated Net Effect on Operating Cost, Revenues, Staffing?	\$0	Comments:	

Project Planning:

Proposed Start Date of Project: unknown

How was estimated cost determined? Estimated

Is Funding Necessary for Further Plans/Estimating? _____

Can the Project be Phased? If yes, expenditure by year _____

	FY21	FY22	FY23	FY24	FY25	FY26	FY27	FY28	FY29	FY30+	TOTAL
PROPOSED	\$	\$	\$	\$	\$38,000	\$	\$	\$	\$	\$	\$38,000
CIC RECC.	\$	\$	\$	\$	\$	\$	\$	\$	\$	\$	\$
APPROVED	\$	\$	\$	\$	\$	\$	\$	\$	\$	\$	\$

Town of West Newbury Capital Improvement Program - Project Request SL CIP CODE DPW-038



Date: 11/18/2020, reviewed/confirmed 10/3/23 Dept. Priority (1 of 3, etc.): 1
 Department: DEPARTMENT OF PUBLIC WORKS Est. Funding Request: \$90,000
 Project Title: Town Buildings - Replacement of backup generator Est. Useful Life (Years): 25 years
 Contact: Brian Richard, DPW/Facilities

Previously Presented? Yes No If Yes, when? (FY):

Project Type: Check All That Apply -

Scheduled Replacement	<input checked="" type="checkbox"/>	Expanded Service	<input type="checkbox"/>	Deemed Critical by Dept.	<input checked="" type="checkbox"/>
Present Equipment Obsolete	<input checked="" type="checkbox"/>	New Operation	<input type="checkbox"/>	Regulatory Requirement	<input type="checkbox"/>
Replace Worn-out Equipment	<input checked="" type="checkbox"/>	Improved Efficiency/Procedures	<input type="checkbox"/>	Other	<input type="checkbox"/>
Health and Life Safety	<input checked="" type="checkbox"/>	New Revenue	<input type="checkbox"/>		

Project Description:

The current back up generator to the Town Offices is over 30 years old. This generator is inadequate to fully support the needs of the building, costly to maintain and becoming more unreliable. The existing generator only supplies power to about 20% of the building, as a result, the building or the Annex can not be used as an emergency shelter in case of a town wide emergency. A new generator will be equipped to supply full power to the Town Offices and most importantly the Annex which would act as our emergency shelter when or if needed.

The estimated cost includes a new generator and the electrical equipment and labor.

Photo (click image to insert):



Project Financing:

Total Project Cost:	\$90,000	Stabilization Funding:	\$0
Amount & Type of Other Local Funding (ie. CPC, bond, op. budget):	\$0	Comments:	
Amount and Type of Non-Local Funding Sources (ie. Grant):	\$0	Comments:	

Future Costs & Operating Expenses:

Estimated Annual Cost of Operation & Maintenance	\$2,000	Comments:	
Estimated Net Effect on Operating Cost, Revenues, Staffing?	\$0	Comments:	

Project Planning:

Proposed Start Date of Project: unknown

How was estimated cost determined? Estimated

Is Funding Necessary for Further Plans/Estimating? _____

Can the Project be Phased? If yes, expenditure by year _____

	FY21	FY22	FY23	FY24	FY25	FY26	FY27	FY28	FY29	FY30+	TOTAL
PROPOSED	\$	\$	\$	\$	\$90,000	\$	\$	\$	\$	\$	\$90,000
CIC RECC.	\$	\$	\$	\$	\$	\$	\$	\$	\$	\$	\$
APPROVED	\$	\$	\$	\$	\$	\$	\$	\$	\$	\$	\$

ARTICLE REQUEST FORM - Capital Request

ARTICLE: *To replace failing sections of concrete flooring throughout the Page School.*

AMOUNT REQUESTED: \$50,000

CONTACT PERSON: Brian Richard, DPW Facilities Manager

PHONE NUMBER: (978) 363-1100 x129

Date: 02/4/2024

Why should the Town make this purchase? What needs will be met? Who will benefit?

Due to the age of the Page School Infrastructure and the construction method used to construct the floors in the school, sections of the concrete base floors at multiple locations in the hallways around the school require major repairs. These floor deficiencies are trip hazards to the general public and should be repaired to ensure public safety. Multiple sections have been repaired over the years and should be continued on an as-needed basis.

What factors affect the timing of this purchase?

The floors in the school continue to crack and fail. Allocating funds will allow them to be repaired on an as-needed basis, and will keep the limit of cracking to a minimum. If we don't address these smaller sections in a timely manner, these cracks will get larger and could greatly increase the repair costs.

When should this Article be sunsetted - how long will the project take?

Recommended sunset date of June 30, 2026

What ancillary costs do you anticipate? (Maintenance, Insurance, Training, etc.)

N/A

Does this Article involve improvement, preservation or creation of tangible Town-owned assets and projects which 1) have useful life of at least five years; 2) cost over \$20,000 and or 3) for which the Town is authorized to borrow funds? If so, please confirm that this item is on the Capital Improvements Committee Schedule for future capital investments.

Yes

Please attach additional pages or other supporting documentation.

Town of West Newbury Capital Improvement Program - Project Request summary

CIP CODE PGE-002



Date: 1/4/2020 with updates through 2/2/24
Dept. Priority (1 of 3, etc.): 1
Department: Department of Public Works
Est. Funding Request: \$240,000
Project Title: Page School Floor Repairs
Est. Useful Life (Years): 50 years
Contact: Brian Richard, Facilities Manager
Previously Presented? Yes No **If Yes, when? (FY):**

Scheduled Replacement	<input type="checkbox"/>	Expanded Service	<input type="checkbox"/>	Deemed Critical by Dept.	<input checked="" type="checkbox"/>
Present Equipment Obsolete	<input type="checkbox"/>	New Operation	<input type="checkbox"/>	Regulatory Requirement	<input type="checkbox"/>
Replace Worn-out Equipment	<input type="checkbox"/>	Improved Efficiency/Procedures	<input type="checkbox"/>	Other	<input type="checkbox"/>
Health and Life Safety	<input checked="" type="checkbox"/>	New Revenue	<input type="checkbox"/>		

Project Description:
 Due to the age of the Page School Infrastructure and the construction method used to construct the floors in the school, sections of the concrete base floors at multiple locations in the hallways around the school require major repairs. These floor deficiencies are trip hazards to the general public and should be repaired to ensure public safety. Multiple sections have been repaired over the years and should be continued on an as-needed basis.



Project Financing:
 Total Project Cost: \$240,000 Stabilization Funding: \$240,000
 Amount & Type of Other Local Funding (ie. CPC, bond, op. budget): \$0 Comments:
 Amount and Type of Non-Local Funding Sources (ie. Grant): \$0 Comments:
Future Costs & Operating Expenses:
 Estimated Annual Cost of Operation & Maintenance: \$0 Comments:
 Estimated Net Effect on Operating Cost, Revenues, Staffing?: \$0 Comments:

Project Planning:
 Proposed Start Date of Project: Ongoing (phased)
 How was estimated cost determined? Cost of previous projects
 Is Funding Necessary for Further Plans/Estimating?
 Can the Project be Phased? If yes, expenditure by year
Yes. Funding repairs/replacements at \$40-50k per phase.

	FY21	FY22	FY23	FY24	FY25	FY26	FY27	FY28	FY29	FY30+	TOTAL
PROPOSED	\$40,000	\$	\$	\$0	\$50,000	\$0	\$50,000	\$0	\$50,000	\$50,000	\$240,000
CIC RECC.	\$	\$	\$	\$	\$	\$	\$	\$	\$	\$	\$
APPROVED	\$	\$	\$	\$	\$	\$	\$	\$	\$	\$	\$

Town of West Newbury Capital Improvement Program - Project Request summary

CIP CODE PGE-005



Date: 1/4/2020 UPDATED 2/4/24 Dept. Priority (1 of 3, etc.): 1
 Department: Department of Public Works Est. Funding Request: \$150,000
 Project Title: Page School Interior Improvements Est. Useful Life (Years): 25 years
 Contact: Brian Richard, Facilities Manager
 Previously Presented? Yes No If Yes, when? (FY):

Project Type: Check All That Apply -

Scheduled Replacement	<input checked="" type="checkbox"/>	Expanded Service	<input type="checkbox"/>	Deemed Critical by Dept.	<input checked="" type="checkbox"/>
Present Equipment Obsolete	<input checked="" type="checkbox"/>	New Operation	<input type="checkbox"/>	Regulatory Requirement	<input checked="" type="checkbox"/>
Replace Worn-out Equipment	<input checked="" type="checkbox"/>	Improved Efficiency/Procedures	<input type="checkbox"/>	Other	<input type="checkbox"/>
Health and Life Safety	<input checked="" type="checkbox"/>	New Revenue	<input type="checkbox"/>		

Project Description:
 The Page School Interior finishings are in dire need of replacement and repairs. Ceiling tiles, plaster, doors and doorways and overall much of the woodwork needs replacement or repairs. This project can be done over a multiple year period.

Photo (click image to insert):



Project Financing:
 Total Project Cost: \$150,000 Stabilization Funding: \$
 Amount & Type of Other Local Funding (ie. CPC, bond, op. budget): \$0 Comments:
 Amount and Type of Non-Local Funding Sources (ie. Grant): \$0 Comments:

Future Costs & Operating Expenses:
 Estimated Annual Cost of Operation & Maintenance: \$0 Comments:
 Estimated Net Effect on Operating Cost, Revenues, Staffing? \$0 Comments:

Project Planning:
 Proposed Start Date of Project: Aug-23
 How was estimated cost determined? Estimated.
 Is Funding Necessary for Further Plans/Estimating?
 Can the Project be Phased? If yes, expenditure by year

	FY21	FY22	FY23	FY24	FY25	FY26	FY27	FY28	FY29	FY30+	TOTAL
PROPOSED	\$	\$	\$	\$	\$75,000	\$0	\$75,000	\$	\$	\$	\$0 \$150,000
CIP RECC.	\$	\$	\$	\$	\$	\$	\$	\$	\$	\$	\$
APPROVED	\$	\$	\$	\$	\$	\$	\$	\$	\$	\$	\$

Town of West Newbury
2024 Spring Town Meeting (FY25)

29

ARTICLE REQUEST FORM

ARTICLE: *Purchase Replacement Dump Truck with Plow*

AMOUNT REQUESTED: \$350,000 (Capital Request)

CONTACT PERSON: Butch Hills, Highway Superintendent

PHONE NUMBER: 978-363-1100 x120

Why should the Town make this purchase? What needs will be met? Who will benefit?

As scheduled for replacement in the Capital Improvement Plan of FY2025, the Department of Public Works would like to request funding to replace a 2011 International Dump Truck (Truck #6), which is currently equipped with a salter unit and plow. This heavily used vehicle has 36,376 miles and 2,950 hours of run time. The vehicle has major rust issues including body and frame rust, and the engine has been known to have longevity issues. With only three full size plow trucks for the whole town, this truck is utmost important in our snow and ice operations.

What factors affect the timing of this purchase?

When should this Article be sunsetted - how long will the project take?

Recommended sunset date of June 30, 2026

What ancillary costs do you anticipate? (Maintenance, Insurance, Training, etc.)

\$5,000-\$6,000/annually for maintenance.

Does this Article involve improvement, preservation or creation of tangible Town-owned assets and projects which 1) have useful life of at least five years; 2) cost over \$20,000 and or 3) for which the Town is authorized to borrow funds? If so, please confirm that this item is on the Capital Improvements Committee Schedule for future capital investments.

This article is a free cash request and meets the criteria for a Capital project. (DPW-010)

Please attach additional pages or other supporting documentation.

Town of West Newbury Capital Improvement Program - Project Request summary

CIP CODE DPW-010



Date: 12/27/2019, updated 12/11/23, updated 2/1/24 Dept. Priority (1 of 3, etc.): 1
 Department: DEPARTMENT OF PUBLIC WORKS Est. Funding Request: \$350,000
 Project Title: PURCHASE REPLACEMENT DUMP TRUCK W/PLOW Est. Useful Life (Years): 10 YEARS
 Contact: Butch Hills, Highway Superintendent
 Previously Presented? Yes No If Yes, when? (FY): _____

Project Type: Check All That Apply -

Scheduled Replacement	<input checked="" type="checkbox"/>	Expanded Service	<input type="checkbox"/>	Deemed Critical by Dept.	<input checked="" type="checkbox"/>
Present Equipment Obsolete	<input type="checkbox"/>	New Operation	<input type="checkbox"/>	Regulatory Requirement	<input type="checkbox"/>
Replace Worn-out Equipment	<input checked="" type="checkbox"/>	Improved Efficiency/Procedures	<input checked="" type="checkbox"/>	Other	<input type="checkbox"/>
Health and Life Safety	<input type="checkbox"/>	New Revenue	<input type="checkbox"/>		

Project Description:
 As scheduled for replacement in the Capital Improvement plan of FY2019, DPW would like to request the replacement of a 2011 International dump truck (Truck #2) which is currently equipped with a salter unit and plow. This heavily used vehicle has xx miles and xx hours of run time. The current truck has major rust issues. With only three full size plow trucks for the whole town, this truck is of utmost important in our snow and ice operations. (New truck will become Truck #6).



Project Financing:
 Total Project Cost: _____ \$350,000 Stabilization Funding: _____ \$0
 Amount & Type of Other Local Funding (ie. CPC, bond, op. budget): _____ \$0 Comments: _____
 Amount and Type of Non-Local Funding Sources (ie. Grant): _____ \$0 Comments: _____
Future Costs & Operating Expenses:
 Estimated Annual Cost of Operation & Maintenance: _____ \$4,000 Comments: _____
 Estimated Net Effect on Operating Cost, Revenues, Staffing? _____ \$0 Comments: _____

Project Planning:
 Proposed Start Date of Project: _____ Would order vehicle in Summer of 2024 with est delievery of winter 2025.
 How was estimated cost determined? _____ Received quote, Jan. 31, 2024.
 Is Funding Necessary for Further Plans/Estimating? _____
 Can the Project be Phased? If yes, expenditure by year _____

	FY21	FY22	FY23	FY24	FY25	FY26	FY27	FY28	FY29	FY30+	TOTAL
PROPOSED	\$	\$	\$	\$	\$350,000	\$	\$	\$	\$	\$	\$350,000
CIC RECC.	\$	\$	\$	\$	\$	\$	\$	\$	\$	\$	\$
APPROVED	\$	\$	\$	\$	\$	\$	\$	\$	\$	\$	\$



MINUTEMAN TRUCKS, INC.

2181 Providence Highway • Walpole, MA 02081
 P: 508.668.3112 TF: 800.225.4808
 International | Ford

Presented in accordance with Greater Boston Police Council Cooperative Procurement Program/MAPC.
 Contract# GBPC 2023 Trucks - Pricing valid through: 11/30/2024 Current contract available upon request.

Town of West Newbury	2025 HV607 Snow Fighter with Patrol Wing Dump Plow Sander
Butch	
381 Main Street	
West Newbury, Massachusetts 01985	
978-363-1100	

January 31, 2024

Based on our previous discussions, I have prepared the following proposal for your review.

Option ID	Description	Unit Price
BASE UNIT AND CHASSIS OPTIONS		
x	110-3000 2024	\$ 99,750.00
x	3105 120,000 PSI Severe Duty Frame 10.866"	\$ 697.00
x	3112 Corrosion Resistant Frame Coating for Single Frame	\$ 603.00
x	3114 Extra Fuel/Oil Capacity 10 to 25 gal	\$ 454.00
x	3130 Cummins L9 330 hp @ 1000 ft lbs Torque	\$ 1,580.00
x	3146 Horizontal Aftertreatment w/ Vertical Exhaust Outlet (choice of straight, curved, or	\$ 1,750.00
x	3147 Polished Aftertreatment Device Cover	\$ 549.00
x	3149 Engine Compression Brake	\$ 2,750.00
x	3155 Neutral At Stop	\$ 213.00
x	3160 Stainless Steel Cooler Lines	\$ 575.00
x	3165 Aluminum Air Tanks	\$ 579.00
x	3167 Electronic Traction Control (Air Brake)	\$ 212.00
x	3171 Electric Trailer Brake Prep	\$ 212.00
x	3174 18,000 lb. Capacity Front Axle	\$ 2,627.00
x	3192 30,000 lb. Capacity Rear Axle w/ Cast Brake Shoes	\$ 4,640.00
x	3196 Full Lock Rear Differential Single Axle	\$ 961.00
x	3205 31,000 lb. Rear Suspension ILO 23,500 lb. Suspension	\$ 330.00
x	3229 12R22.5 Tires Per Axle	\$ 816.00
x	3230 315R22.5 Tires w/ Wheels Per Axle	\$ 1,179.00
x	3234 Aluminum Wheels 4x2	\$ 1,537.00
x	3237 Spare Tire & Wheel Each 9.00" & Larger	\$ 1,179.00
x	3244 Premium Interior Package	\$ 510.00
x	3248 Dual Air Seat	\$ 1,738.00
x	3251 Safety Color Seatbelts (Red or Orange)	\$ 42.00
x	3252 Power Windows / Locks	\$ 312.00
x	3254 Safety & Convenience Package: Lamp Check; Lights on w/ Wiper; Wiper Save; Bra	\$ 574.00
x	3255 Plow Light Switch & Harness Prep	\$ 381.00
x	3257 Fixed Grill	\$ 453.00
x	3143 Stainless Steel Oil Pan - Cummins L9	\$ 3,250.00
x	3258 Bug/Ember Screen	\$ 336.00
x	3261 Bright Mirrors	\$ 211.00
x	3263 Stainless Tank Straps	\$ 211.00
x	3264 Single Side Frame Air Horn	\$ 275.00
x	3267 Air Conditioning	\$ 685.00
x	3268 Block Heater	\$ 273.00
x	3269 Hood Mounted Mirrors/Light Brackets	\$ 272.00
x	3272 Power Side Mirrors	\$ 277.00
x	3273 Heated Windshield	\$ 456.00
x	3275 Remote Power Module Each	\$ 825.00
x	3279 Snow Valve	\$ 340.00
x	9405 24 mos	\$ 800.00
x	9315 60-Month/100,000 Miles (160,000 km), Chassis EXCLUDING Engine & Transmis	\$ 3,494.00
x	9327 60-Month/100,000 Miles (160,000 km), Engine & Aftertreatment EXCLUDING CH	\$ 4,530.00
x	9337 Allison 3000/3500 Series 60-Month / Unlimited Miles - Each Addtl 2 Year Perio	\$ 750.00
BODY & EQUIPMENT OPTIONS		
x	5908 HYDRAULIC SYSTEM: TRANSMISSION MOUNTED PTO	\$ 11,395.00
x	5951 BIBEAU 11' DUMP BODY: 6 TO 8 CY HOIST: FRONT TELESCOPIC	\$ 26,500.00
x	5979 UPCHARGE FOR 10'/11' HARDOX STEEL DUMP BODY ILO CARBON STEEL	\$ 6,890.00
x	6251 AIR OPERATED TAILGATE	\$ 1,102.00
x	6256 STEEL TAILGATE CHUTE Qty 3	\$ 3,180.00
x	6264 AERO LOAD COVER: AUTO ELECTRIC	\$ 4,081.00
x	6280 3/4" REINFORCED PLATE W/ D RINGS AND LIGHT PLUG - PINTLE	\$ 1,590.00
x	6291 STEEL BODY STEPS/LADDER - EA	\$ 375.00
x	6299 SANDER SPILL SHIELD - STEEL EACH Qty 2	\$ 3,000.00
x	6704 EVEREST HEAVY DUTY PLOW FRAME - POWER TILT QUICK COUPLER WITH	\$ 12,720.00
x	6707 EVEREST JAW COUPLER ATTACHMENT FOR SNOW PLOW	\$ 451.00
x	6710 JCM HEAVY DUTY PLOW FRAME - LOW MOUNT - JCM PIN-ON WITH LIGHTS AND	\$ 10,600.00
x	6736 POWER REVERSE HYDRAULICS W/ CONTROLS	\$ 2,915.00
x	6751 EVEREST HEAVY DUTY 11' POWER REVERSING PLOW - TRIP EDGE	\$ 17,490.00
x	6760 EVEREST WING SYSTEM: PATROL - INCLUDES VALVES OR CONTROLS	\$ 31,800.00
x	6798 ADD FOR "VORTEX" MOLDBOARD IN LIEU OF STEEL	\$ 1,590.00
x	6849 HIWAY SPREADER - 10' - 304 STAINLESS STEEL	\$ 25,970.00
x	6856 EXTENDED GREASE LINES AND IDLERS - RECCOMENDED FOR DUMP	\$ 636.00
x	6906 CIRUS ELECTRIC SPREADER CONTROL VALVE: EZ-2 SPREAD SPINNER/AUGER	\$ 7,685.00
x	6922 MANUAL SPREADER CONTROL VALVE: 2FFL	\$ 5,141.00
x	8890 (1) STAINLESS STEEL LIGHT BAR - WITH S/T & FLASHERS - LED	\$ 2,694.00
x	8892 (2) 4" FLOOD LIGHT - LED Qty 2	\$ 1,438.00
x	8896 LED WARNING SYSTEM: FRONT GRILL AND TWO REAR MOUNTED FLASHERS	\$ 2,694.00
x	8899 LED WARNING SYSTEM: TWO REAR MOUNTED FLASHERS WITH S/T	\$ 1,796.00
x	8942 TEMPERATURE SENSOR: HIGH SERRIA	\$ 4,759.00
OPTIONS NOT INCLUDED IN CONTRACT		
		\$ 332,680.00
	TRADE VALUE(as a negative number)	none
Trade Description:		
Trade Vin:		
PO Total Required	NET DUE	\$ 332,680.00
ADDITIONAL OPTIONS TO SELECT		
	NEW PO TOTAL REQUIRED (hand write).....	\$ 332,680.00
	DEALER APPROVAL	
	TOWN APPROVAL	

From: [Dominick La Gambina](#)
To: [Highway](#)
Cc: [DPW Director](#)
Subject: RE: New 2025 Budget Contract Price
Date: Thursday, February 1, 2024 7:45:29 AM
Attachments: [Town of West Newbury 2025 HV607 Snow Fighter Patrol Wing Dump MAPC GBPC Contract 013124.pdf](#)
[Town of West Newbury 2025 HV607 Snow Fighter Dump MAPC GBPC Contract 013124.pdf](#)

Hi Butch,

Here is the options updated for the Dump and then the Dump with Patrol Wing.

You may want to (I recommend you do) add a \$ 10,000.00 charge from Cummins for Carb Emissions non-compliance penalty. Massachusetts is supposed to be one of 16 Carb States and if they do, any truck registered and built with 2025 Engine will have a Cummins Carb surcharge/penalty in Massachusetts.

Call me and Ill explain

Dominick

Disclaimer Confidentiality Notice: This e-mail, and any attachments and/or documents linked to this email, are intended for the addressee and may contain information that is privileged, confidential, proprietary, or otherwise protected by law. Any dissemination, distribution, or copying is prohibited. This notice serves as a confidentiality marking for the purpose of any confidentiality or nondisclosure agreement. If you have received this communication in error, please contact the original sender.

Town of West Newbury
2024 Spring Town Meeting (FY25)

30

ARTICLE REQUEST FORM

ARTICLE: *Zero -Turn Mower for the Highway Department*

AMOUNT REQUESTED: \$33,500 (Capital Request)

CONTACT PERSON: Butch Hills, Highway Superintendent

PHONE NUMBER: 978-363-1100 x120

Why should the Town make this purchase? What needs will be met? Who will benefit?

As scheduled for replacement in the Capital Improvement Plan of FY2025, the Department of Public Works would like to request funding to replace our current 2002 Zero Turn mower (Truck #27). This mower is currently used for the mowing of town properties. The DPW is hoping to purchase a Kubota ZD 1211-3-60 zero-turn mower with a climate controlled Curtis Cab. The Curtis Cab would protect the operator from extreme dust, heat and noise. Replacement parts for the 2002 Zero Turn mower are extremely difficult to locate. There have also been reliability issues, such as electrical issues and overheating, and the need to replace is becoming more apparent.

What factors affect the timing of this purchase?

When should this Article be sunsetted - how long will the project take?

Recommended sunset date of June 30, 2026

What ancillary costs do you anticipate? (Maintenance, Insurance, Training, etc.)

\$1,000-\$1,500/annually for maintenance.

Does this Article involve improvement, preservation or creation of tangible Town-owned assets and projects which 1) have useful life of at least five years; 2) cost over \$20,000 and or 3) for which the Town is authorized to borrow funds? If so, please confirm that this item is on the Capital Improvements Committee Schedule for future capital investments.

This article is a free cash request and meets the criteria for a Capital project. (DPW-004)

Please attach additional pages or other supporting documentation.



www.MBTRACTOR.com

MB TRACTOR & EQUIPMENT

Route 125, P.O. Box 487

Plaistow, NH 03865

TEL: (603) 382-5031

Fax: (603) 382-1084

WWW.MBTRACTOR.COM

THE BEST TRACTORS
& EQUIPMENT ON EARTH!

SOLD TO *** emailed ***
TOWN03 TOWN OF WEST NEWBURY DPW
TOWN HALL
381 MAIN STREET
WEST NEWBURY, MA 01985

SHIP TO

QUOTATION

Sold By: Z88 PO #: Date 1/26/24 QUOTE PO22788
Ship By: Tax #: 12:50:35 PRT: 1 Open

Tax	D	Qty	Description	Price	Amount
			Group: 01		
			EQUIPMENT QUOTE		
N		1	KUBOTA ZD1211-3-60	19990.00	19990.00
N		1	CURTIS AC CAB FOR ZD	11123.75	11123.75
N		1	INSTALL AND FRT	1800.00	1800.00
			** TOTAL EQUIPMENT QUOTE		32913.75

Quotes are valid for thirty days. Prices are subject to change at vendors discretion. All prices quoted FOB vendor shipping point unless specifically noted.
Special order parts are to be prepaid in full in advance, charged to a valid open account, or billed to a credit card.
There are no returns of special order parts.
TRUCKING IS NOT COVERED BY THE MANUFACTURERS WARRANTY. TRUCKING COSTS ARE THE RESPONSIBILITY OF THE CUSTOMER.
Price on this sales quote is an estimate and is subject to being increased. Final pricing and applicable programs will be established at Delivery.
Order cancellation and refund of earnest money deposits are available in the event of a price increase between the date of the quote and the date of delivery.

** SUBTOTAL 32913.75

X _____ Charge Sale

Phone: (978) 363-1106 PAY THIS AMOUNT \$32913.75

**Town of West Newbury
2024 Spring Town Meeting (FY25)**

31

ARTICLE REQUEST FORM

ARTICLE: *Additional Accessories for the Trackless MT7*

AMOUNT REQUESTED: \$41,540

CONTACT PERSON: Butch Hills, Highway Superintendent

PHONE NUMBER: 978-363-1100 x120

Why should the Town make this purchase? What needs will be met? Who will benefit?

The Department of Public Works is seeking to purchase additional accessories for the Trackless MT7 that was purchased in FY24. Additional accessories include a Boom Flail Mower and a set of Dual Tires for use with the Boom Flail Mower; 4 sets of 2 tires on rims. This will allow year-round use of the Trackless MT7.

What factors affect the timing of this purchase?

The sooner we are able to purchase these additional accessories, the sooner we are able to use the Trackless MT7 year-round.

When should this Article be sunsetted - how long will the project take?

Recommended sunset date of June 30, 2026

What ancillary costs do you anticipate? (Maintenance, Insurance, Training, etc.)

Annual of \$3,000 - \$4,000.

Does this Article involve improvement, preservation or creation of tangible Town-owned assets and projects which 1) have useful life of at least five years; 2) cost over \$20,000 and or 3) for which the Town is authorized to borrow funds? If so, please confirm that this item is on the Capital Improvements Committee Schedule for future capital investments.

This article is a free cash request and meets the criteria for a capital project but is not currently on the Capital Improvements Committee Schedule.

Please attach additional pages or other supporting documentation.



C.N. Wood Enviro LLC

an affiliate of C.N. Wood Co., Inc.

10/03/2023

ORDER DATE

WOBURN, MA

BRANCH

200 Merrimac Street
Woburn, MA 01801
(781) 935-1919

140 Wales Ave
Avon, MA 02322
(508) 584-8484

102 State Road
Whately, MA 01093
(413) 665-7009

60 Shun Pike
Johnston, RI 02919
(401) 942-9191

84B Warren Ave
Westbrook, ME 04092
(207) 854-0615

25A Bernhard Road
North Haven, CT 06473
(203) 848-6735

Sales Order

Customer P.O. #

F.O.B. SHIPPED VIA:

Sold To: West Newbury DPW

Ship To: Highway garage

Address: 381 Main Street

693 Main Street

West Newbury MA 01985

Phone: Fax:

Email:

Table with columns: QTY, ITEM #, S/N, DESCRIPTION, EACH, TOTAL. Contains 2 rows of item data.

Table with columns: TRADE #, YEAR, MAKE, MODEL, S/N, HRS, WORKING CONDITION, ALLOWANCE, PAYOFF. Contains 2 rows for TRADE #1 and TRADE #2.

Summary table with columns: Sale Price, Plus Tax, F.E.T., Total, Less Trade, Total Payoff, Less Deposit, Net Due.

Finance Details: (ALL FINANCE IS SUBJECT TO CREDIT APPROVAL)
pricing is per FAC 116

TERMS: [] NET CASH UPON INVOICE [] FINANCE:
CONDITION: [] AS IS [] NEW WARRANTY:

THIS DOCUMENT IS A CONTRACT INCLUDING IMPORTANT TERMS AND CONDITIONS. I HAVE REVIEWED AND ACCEPT ALL TERMS AND CONDITIONS, INCLUDING WITHOUT LIMITATION THOSE ON PAGES 2 - 4 OF THIS CONTRACT. I HAVE READ THIS CONTRACT AND AUTHORIZE THE ENTRY OF THE ABOVE ORDER SUBJECT TO THE TERMS AND CONDITIONS CONTAINED HEREIN

SELLER: C.N. WOOD ENVIRO, LLC PURCHASER:
BY: SALES REP PRINT NAME:
ACCEPTED: AUTHORIZED SIGNATURE SIGNATURE: BUYER (If Corporation, Signature and Title of Officer)

THIS ORDER NOT ACCEPTED OR BINDING UNTIL APPROVED BY AN OFFICER OF C.N. WOOD ENVIRO, LLC

From: [Highway](#)
To: [DPW Admin](#)
Subject: FW: MT7
Date: Thursday, January 25, 2024 12:17:58 PM

From: Katherine Boshar <katherine@cn-wood.com>
Sent: Thursday, January 25, 2024 12:10 PM
To: Highway <highway@wnewbury.org>
Subject: Re: MT7

I believe that date will still hold. Thanks for your patience with this. Equipment is just So slow lately.

The pricing should be exactly the same as it was. Prices have not gone up... Yet. I will let you know if it changes but I do expect them to go up every year so you might want to add another 4% or so just in case.

Katherine

Get [Outlook for iOS](#)

From: Highway <highway@wnewbury.org>
Sent: Thursday, January 25, 2024 12:01:52 PM
To: Katherine Boshar <katherine@cn-wood.com>
Subject: MT7

ARTICLE REQUEST FORM

ARTICLE: Supplemental funds for telecom replacement/upgrades at Town Offices (1910 Building), Public Safety Complex, and Library

AMOUNT REQUESTED: TBD. (Proposals expected on March 13, 2024, at which time cost will be proposed).

CONTACT PERSON: Christine Wallace, PE, Projects/Programs Manager

PHONE NUMBER: 978-363-1100 ext. 130

Why should the Town make this purchase? What needs will be met? Who will benefit?

Town Meeting previously appropriated \$65,000 to support this project (ATM Article 18, 5/14/22). (Prior project summary sheet attached). After more than a year of research including many Town departments, and the Town's IT consultant, the Town issued a RFP for this project in December 2023. Many prospective firms attended the mandatory pre-submission on January 17, 2024. Following the pre-submission meeting and walk-through, the Town departments involved have updated our recommendation, and recommend that the project scope (for the 1910 Building) be expanded to include replacement, rerouting and upgrade of all telecom and network cabling. The Town issued an Addendum to the RFP (Addendum #5) on January 29, 2024 in order to notify prospective vendors that the scope will be expanded, and to extend the response time to receive proposals until March 13, 2024. Subject to obtaining sufficient funding, it is expected that a contract to complete this work would be awarded on or after April 30, 2024.

What factors affect the timing of this purchase?

This project is long overdue, and causes daily operational challenges and customer inconveniences at the Town Offices.

When should this Article be sunsetted - how long will the project take?

End of FY26. (Expected to be complete by end of FY25)

What ancillary costs do you anticipate? (Maintenance, Insurance, Training, etc.)

None

Does this Article involve improvement, preservation or creation of tangible Town-owned assets and projects which 1) have useful life of at least five years; 2) cost over \$20,000 and or 3) for which the Town is authorized to borrow funds? If so, please confirm that this item is on the Capital Improvements Committee Schedule for future capital investments.

Yes

Please attach additional pages or other supporting documentation.

**Town of West Newbury
2022 Spring Town Meeting**

ARTICLE REQUEST FORM

ARTICLE: *Request to fund the replacement of Town Offices phone system including all hardware and software.*

AMOUNT REQUESTED: \$65,000

CONTACT PERSON: Wayne S. Amaral, DPW Director

PHONE NUMBER: (978) 363-1100 x120

Date: 1/25/2022

Why should the Town make this purchase? What needs will be met? Who will benefit?

The current phone system including the hardware and software was replaced over 10-years ago with a used system that was already outdated at the time. The system is declining due to the age of the equipment. The current system has very poor sound quality and the software is not supported any longer. To repair such an outdated system has been a challenge and we have been having an extremely difficult time locating replacement hardware and software. We also have major limitations with our voicemail options. With the services expected by our residents we should have the most adaptable communication system that allows town staff to communicate in the most efficient, reliable and user friendly ways possible.

What factors affect the timing of this purchase?

Scheduled for replacement in our FY2023 Capital Budget Plan. If the system has a major failure - there is a very good chance that we will not be able to find the software or hardware to repair it. This would result in no phone service in the Town Offices until a new system is installed which can take an estimated 4-6 months.

When should this Article be sunsetted - how long will the project take?

Recommended sunset date of June 30, 2024

What ancillary costs do you anticipate? (Maintenance, Insurance, Training, etc.)

The yearly cost is unknown at this time until a system is determined, so at this time we estimate the yearly operating cost at \$6,000 a year.

Does this Article involve improvement, preservation or creation of tangible Town-owned assets and projects which 1) have useful life of at least five years; 2) cost over \$20,000 and or 3) for which the Town is authorized to borrow funds? If so, please confirm that this item is on the Capital Improvements Committee Schedule for future capital investments.

The useful life of this type of system is 10-12 years.

Please attach additional pages or other supporting documentation.

See capital request form

TOWN OF WEST NEWBURY CAPITAL IMPROVEMENT PROGRAM - PROJECT REQUEST SUMMARY

CIP CODE (DPW-037)



Date: NOVEMBER 4, 2020 **Dept. Priority (1 of 3, etc.):** 1
Department: DEPARTMENT OF PUBLIC WORKS **Est. Funding Request:** \$65,000
Project Title: TOWN BUILDINGS - PHONE SYSTEM REPLACEMENT **Est. Useful Life (Years):** 20-25 YEARS
Contact: WAYNE S. AMARAL DPW DIRECTOR
Previously Presented? YES NO **If Yes, when? (FY):** _____

Project Type: Check All That Apply -

Scheduled Replacement	<input checked="" type="checkbox"/>	Expanded Service	<input type="checkbox"/>	Deemed Critical by Dept.	<input checked="" type="checkbox"/>
Present Equipment Obsolete	<input checked="" type="checkbox"/>	New Operation	<input type="checkbox"/>	Regulatory Requirement	<input type="checkbox"/>
Replace Worn-out Equipment	<input checked="" type="checkbox"/>	Improved Efficiency/Procedures	<input type="checkbox"/>	Other	<input type="checkbox"/>
Health and Life Safety	<input type="checkbox"/>	New Revenue	<input type="checkbox"/>		

Project Description:

The current phone system the town uses was updated in 2012 with a used system that at the time had limited options for expansion and upgrades. Now the system is starting to fail and parts and equipment are almost impossible to locate. Most important, the connection quality and versatility that is required to operate a town communication system is inadequate for our current and future needs.

Photo (click image to insert):



Project Financing:

Total Project Cost: \$65,000 **Stabilization Funding:** \$ 0
Amount & Type of Other Local Funding (ie. CPC, bond, op. budget): \$ 0 **Comments:** _____
Amount and Type of Non-Local Funding Sources (ie. Grant): \$ 0 **Comments:** _____

Future Costs & Operating Expenses:

Estimated Annual Cost of Operation & Maintenance \$ 6,000 **Comments:** _____
Estimated Net Effect on Operating Cost, Revenues, Staffing? \$ 0 **Comments:** _____

Project Planning:

Proposed Start Date of Project: UNKNOWN
How was estimated cost determined? Estimated
Is Funding Necessary for Further Plans/Estimating? _____
Can the Project be Phased? If yes, expenditure by year _____

	FY21	FY22	FY23	FY24	FY25 +	Total
PROPOSED	\$	\$	\$ 65,000	\$	\$	\$ 65,000
CIC RECC.	\$	\$	\$	\$	\$	\$
APPROVED	\$	\$	\$	\$	\$	\$

Town of West Newbury
2024 Spring Town Meeting (FY25)

33

ARTICLE REQUEST FORM

ARTICLE: *Town Office and Town Hall Electronic Keying System*

AMOUNT REQUESTED: \$35,000 (Capital Request)

CONTACT PERSON: Brian Richard, Facilities Manager

PHONE NUMBER: 978-914-2546

Why should the Town make this purchase? What needs will be met? Who will benefit?

The existing lock system in the Town Offices is outdated and finding parts to repair is becoming a challenge. Most importantly, we would like to have a system that can use a code, key card or fob system that would allow the DPW the ability to secure locks in town-wide facilities on a computer system. This system would allow entrance doors to this facility to be unlocked and locked at preprogrammed times and eliminate giving keys to staff, public committees and rental users.

What factors affect the timing of this purchase?

Town Offices is seeing heavier usage due to committee and community engagement meetings. Some staff are carrying 10+ keys to these buildings. We would like to have a higher level of security, which the electronic keying system offers, while also having a more convenient way of entering the buildings for staff, committees and rental users.

When should this Article be sunsetted - how long will the project take?

Recommended sunset date of June 30, 2026

What ancillary costs do you anticipate? (Maintenance, Insurance, Training, etc.)

\$1,000 annual maintenance.

Does this Article involve improvement, preservation or creation of tangible Town-owned assets and projects which 1) have useful life of at least five years; 2) cost over \$20,000 and or 3) for which the Town is authorized to borrow funds? If so, please confirm that this item is on the Capital Improvements Committee Schedule for future capital investments.

This article is a free cash request and meets the criteria for a Capital project. (DPW-035)

Please attach additional pages or other supporting documentation.

Town of West Newbury Capital Improvement Program - Project Request summary

CIP CODE DPW-035



Date: 1/9/2020 UPDATED 2/2/24
 Department: DEPARTMENT OF PUBLIC WORKS
 Project Title: Town Office and Town Hall – Electronic Keying System
 Contact: Brian Richard, Facilities Manager
 Dept. Priority (1 of 3, etc.): 1
 Est. Funding Request: \$35,000
 Est. Useful Life (Years): 15-20 YEARS

Previously Presented? Yes No If Yes, when? (FY):

Project Type: Check All That Apply -		
Scheduled Replacement	<input type="checkbox"/>	Expanded Service <input checked="" type="checkbox"/>
Present Equipment Obsolete	<input checked="" type="checkbox"/>	New Operation <input checked="" type="checkbox"/>
Replace Worn-out Equipment	<input type="checkbox"/>	Improved Efficiency/Procedures <input checked="" type="checkbox"/>
Health and Life Safety	<input type="checkbox"/>	New Revenue <input type="checkbox"/>
		Deemed Critical by Dept. <input type="checkbox"/>
		Regulatory Requirement <input type="checkbox"/>
		Other <input type="checkbox"/>

Project Description:
 The existing lock system in both the Town Office, Town Hall and Annex are outdated and finding parts to repair is becoming a challenge. Most important we would like to have a system that can use a code, key card or a fob system that would allow DPW the ability to key locks in town-wide facilities on a computer system. This system would allow entrance doors to these three facilities to be unlocked and locked at preprogrammed times and eliminate giving keys to staff, public committees and rental users.

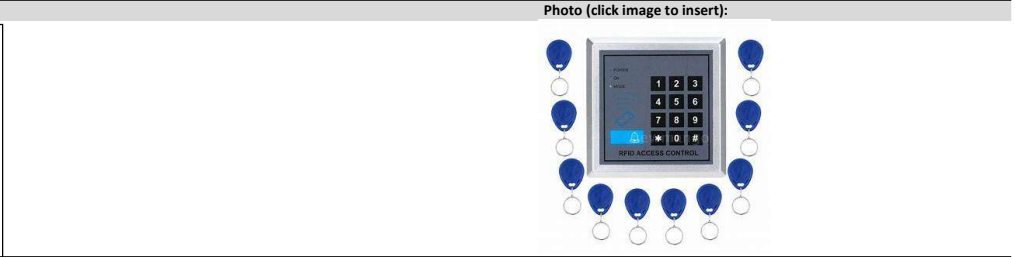

Project Financing:	
Total Project Cost:	\$35,000 Stabilization Funding: \$35,000
Amount & Type of Other Local Funding (ie. CPC, bond, op. budget):	\$0 Comments:
Amount and Type of Non-Local Funding Sources (ie. Grant):	\$0 Comments:
Future Costs & Operating Expenses:	
Estimated Annual Cost of Operation & Maintenance	\$1,000 Comments: Yearly software maintenance fee
Estimated Net Effect on Operating Cost, Revenues, Staffing?	\$0 Comments:

Project Planning:
 Proposed Start Date of Project: fall 2023
 How was estimated cost determined? Estimated
 Is Funding Necessary for Further Plans/Estimating?
 Can the Project be Phased? If yes, expenditure by year

	FY21	FY22	FY23	FY24	FY25	FY26	FY27	FY28	FY29	FY30+	TOTAL
PROPOSED	\$	\$	\$	\$	\$35,000	\$	\$	\$	\$	\$	\$35,000
CIP RECC.	\$	\$	\$	\$	\$	\$	\$	\$	\$	\$	\$
APPROVED	\$	\$	\$	\$	\$	\$	\$	\$	\$	\$	\$

Town of West Newbury
2024 Spring Town Meeting (FY25)

34

ARTICLE REQUEST FORM

ARTICLE: *Replace Pitched Section of Public Safety Complex Roof*

AMOUNT REQUESTED: \$120,000 (Capital Request)

CONTACT PERSON: Brian Richard, Facilities Manager

PHONE NUMBER: 978-914-2546

Why should the Town make this purchase? What needs will be met? Who will benefit?

The pitched section of the Public Safety Complex roof has been showing signs of wear in recent years. Several sections of shingles are lifting, indicating it is time for replacement. This project will include the removal and disposal of asphalt shingles, repair of any damaged roof sheathing, application of ice and water membrane and the installation of a standing seam metal roof. A standing seam metal roof has a lifespan that is 3x that of asphalt roofing.

What factors affect the timing of this purchase?

With the several sections of shingles currently lifting and the heavy rain that we have incurred in more recent years, the need to replace is becoming more and more evident. The risk of leaking is increasing during each rain event.

When should this Article be sunsetted - how long will the project take?

Recommended sunset date of June 30, 2026

What ancillary costs do you anticipate? (Maintenance, Insurance, Training, etc.)

No additional cost anticipated.

Does this Article involve improvement, preservation or creation of tangible Town-owned assets and projects which 1) have useful life of at least five years; 2) cost over \$20,000 and or 3) for which the Town is authorized to borrow funds? If so, please confirm that this item is on the Capital Improvements Committee Schedule for future capital investments.

This article is a free cash request and meets the criteria for a Capital project but is not on the Capital Improvement Program list.

Please attach additional pages or other supporting documentation.

Town of West Newbury Capital Improvement Program - Project Request summary

CIP CODE PD-003



Date: 4-Feb-24 **Dept. Priority (1 of 3, etc.):** 1
Department: Police Department **Est. Funding Request:** \$120,000
Project Title: Replace Pitched Section of Public Safety Complex Roof **Est. Useful Life (Years):** 60 years
Contact: Brian Richard, Facilities Manager
Previously Presented? Yes No **If Yes, when? (FY):**

Project Type: Check All That Apply -

Scheduled Replacement	<input checked="" type="checkbox"/>	Expanded Service	<input type="checkbox"/>	Deemed Critical by Dept.	<input checked="" type="checkbox"/>
Present Equipment Obsolete	<input checked="" type="checkbox"/>	New Operation	<input type="checkbox"/>	Regulatory Requirement	<input type="checkbox"/>
Replace Worn-out Equipment	<input checked="" type="checkbox"/>	Improved Efficiency/Procedures	<input type="checkbox"/>	Other	<input type="checkbox"/>
Health and Life Safety	<input type="checkbox"/>	New Revenue	<input type="checkbox"/>		

Project Description:

The pitched section of the Public Safety Complex roof has been showing signs of wear in recent years. Several sections of shingles are lifting, indicating it is time for replacement. This project will include the removal and disposal of asphalt shingles, repair of any damaged roof sheathing, application of ice and water membrane and the installation of a standing seam metal roof. A standing seam metal roof has a lifespan that is 3x that of asphalt roofing.

With the several sections of shingles currently lifting and the heavy rain that we have incurred in more recent years, the need to replace is becoming more and more evident. The risk of leaking is increasing during each rain event.

Photo (click image to insert):



Project Financing:

Total Project Cost:	\$120,000	Stabilization Funding:	\$0
Amount & Type of Other Local Funding (ie. CPC, bond, op. budget):	\$0	Comments:	
Amount and Type of Non-Local Funding Sources (ie. Grant):	\$0	Comments:	

Future Costs & Operating Expenses:

Estimated Annual Cost of Operation & Maintenance	\$0	Comments:	
Estimated Net Effect on Operating Cost, Revenues, Staffing?	\$0	Comments:	

Project Planning:

Proposed Start Date of Project:	unknown
How was estimated cost determined?	Estimated
Is Funding Necessary for Further Plans/Estimating?	
Can the Project be Phased? If yes, expenditure by year	

	FY21	FY22	FY23	FY24	FY25	FY26	FY27	FY28	FY29	FY30+	TOTAL
PROPOSED	\$	\$	\$	\$	\$120,000	\$	\$	\$	\$	\$0	\$120,000
CIC RECC.	\$	\$	\$	\$	\$	\$	\$	\$	\$	\$	\$
APPROVED	\$	\$	\$	\$	\$	\$	\$	\$	\$	\$	\$

Town of West Newbury
2024 Spring Town Meeting (FY25)

35

ARTICLE REQUEST FORM

ARTICLE: *Public Safety Complex Interior/Exterior Painting and Improvements*

AMOUNT REQUESTED: \$75,000 (Capital Request)

CONTACT PERSON: Brian Richard, Facilities Manager

PHONE NUMBER: 978-914-2546

Why should the Town make this purchase? What needs will be met? Who will benefit?

The Department of Public Works is looking to continue to maintain the Public Safety Complex's great appearance. In order to protect the exterior from environmental impacts, routine painting and spot replacement of the exterior trim is required. Additionally, interior painting is needing to be updated at high-traffic locations in order to keep the clean appearance of this investment. A Boom lift rental is required to reach the high areas.

What factors affect the timing of this purchase?

When should this Article be sunsetted - how long will the project take?

Recommended sunset date of June 30, 2026

What ancillary costs do you anticipate? (Maintenance, Insurance, Training, etc.)

No additional cost anticipated.

Does this Article involve improvement, preservation or creation of tangible Town-owned assets and projects which 1) have useful life of at least five years; 2) cost over \$20,000 and or 3) for which the Town is authorized to borrow funds? If so, please confirm that this item is on the Capital Improvements Committee Schedule for future capital investments.

This article is a free cash request and meets the criteria for a Capital project. (DPW-024)

Please attach additional pages or other supporting documentation.

Town of West Newbury Capital Improvement Program - Project Request summary

CIP CODE DPW-024



Date: 12/27/2019, reviewed/confirmed 10/3/23 Dept. Priority (1 of 3, etc.): 1
 Department: DEPARTMENT OF PUBLIC WORKS Est. Funding Request: \$75,000
 Project Title: Public Safety Complex - Interior & Exterior Painting & Improvements Est. Useful Life (Years): 15 Years
 Contact: Brian Richard, DPW/Facilities

Previously Presented? Yes No If Yes, when? (FY):

Project Type: Check All That Apply -			
Scheduled Replacement	<input checked="" type="checkbox"/>	Expanded Service	<input type="checkbox"/>
Present Equipment Obsolete	<input type="checkbox"/>	New Operation	<input type="checkbox"/>
Replace Worn-out Equipment	<input type="checkbox"/>	Improved Efficiency/Procedures	<input type="checkbox"/>
Health and Life Safety	<input type="checkbox"/>	New Revenue	<input type="checkbox"/>
		Deemed Critical by Dept.	<input type="checkbox"/>
		Regulatory Requirement	<input type="checkbox"/>
		Other	<input type="checkbox"/>

Project Description:
 To continue to maintain the Public Safety Complex's great appearance and protect from the environment, routine painting and spot replacement of the exterior trim is required. Additionally, interior painting may be required at high use locations around the complex and is also important to keep the clean appearance of this investment.



Project Financing:	
Total Project Cost:	\$75,000
Amount & Type of Other Local Funding (ie. CPC, bond, op. budget):	\$0
Amount and Type of Non-Local Funding Sources (ie. Grant):	\$0
Future Costs & Operating Expenses:	
Estimated Annual Cost of Operation & Maintenance	\$
Estimated Net Effect on Operating Cost, Revenues, Staffing?	\$0

Project Planning:
 Proposed Start Date of Project: Summer 2024
 How was estimated cost determined? Estimated
 Is Funding Necessary for Further Plans/Estimating?
 Can the Project be Phased? If yes, expenditure by year

	FY21	FY22	FY23	FY24	FY25	FY26	FY27	FY28	FY29	FY30+	TOTAL
PROPOSED	\$	\$	\$	\$	\$75,000	\$	\$	\$	\$	\$	\$75,000
CIC RECC.	\$	\$	\$	\$	\$	\$	\$	\$	\$	\$	\$
APPROVED	\$	\$	\$	\$	\$	\$	\$	\$	\$	\$	\$



Cat Class Code: 310-3001

30-39 ft. Articulating Boom Lift, Diesel or Gas/LP

Daily	Weekly	Monthly
\$524	\$1,137	\$2,770

[Quick View](#) ▾



Cat Class Code: 310-3050 ZERO EMISSIONS

30-33 ft. Articulating Boom Lift, Electric

Daily	Weekly	Monthly
\$476	\$1,000	\$2,706

[Quick View](#) ▾



Cat Class Code: 310-3450 ZERO EMISSIONS

34-39 ft. Articulating Boom Lift, Electric

Daily	Weekly	Monthly
\$476	\$1,000	\$2,706

[Quick View](#) ▾



Cat Class Code: 310-4001

40-50 ft. Articulating Boom Lift, Diesel or Gas/LP

Daily	Weekly	Monthly
\$659	\$1,414	\$3,023

[Quick View](#) ▾



Cat Class Code: 310-4050 ZERO EMISSIONS

40-46 ft. Articulating Boom Lift, Electric

Daily	Weekly	Monthly
\$487	\$1,127	\$2,749

[Quick View](#) ▾

Town Manager

From: Town Manager
Sent: Saturday, January 27, 2024 1:03 PM
To: Paul Sevigny
Cc: Town Clerk; Town Accountant; Executive Assistant; Rob Phillips (rob-phillips@verizon.net)
Subject: RE: West Newbury/Steele Landfill - updated monitoring requirements - PFAS

Paul, we have set up a folder with backup materials re known/potential warrant articles for April STM; and added your emails and the attachments you provided.

Please either you or BOH prepare an article request form. (The template is the top left link on the FinCom page [here](#)). This is not my requirement but is something both the FinCom and Select Board have directed for all proposed warrant articles. The form can be very brief; the materials you've already provided would be attached and those should give everyone a clear understanding of what's proposed.

Thanks -

Angus Jennings, Town Manager
Town of West Newbury
Town Office Building
381 Main Street
West Newbury, MA 01985
(978) 363-1100 x111
townmanager@wnewbury.org

From: Paul Sevigny <psevigny@wnewbury.org>
Sent: Thursday, January 25, 2024 2:45 PM
To: Town Manager <townmanager@wnewbury.org>; Town Accountant <townaccountant@wnewbury.org>; Executive Assistant <exec.assistant@wnewbury.org>; Rob Phillips (rob-phillips@verizon.net) <rob-phillips@verizon.net>
Subject: FW: West Newbury/Steele Landfill - updated monitoring requirements - PFAS

Hello to All,

Please see email below from MADEP. Based on there willingness to work with us, I will withdraw our Reserve Fund Transfer Request of \$22,915. I spoke with our consultant and we should be able to conduct all the necessary tests in the month of May. So we can either ask for lower amount from the reserve fund (\$7,500) or the full amount of \$22,915 at STM in April. Please let me know which way you would like us to proceed.

From: Fairbrother, Mark (DEP) <mark.fairbrother@mass.gov>
Sent: Thursday, January 25, 2024 1:59 PM
To: Paul Sevigny <psevigny@wnewbury.org>
Subject: RE: West Newbury/Steele Landfill - updated monitoring requirements - PFAS

Paul,

If the sampling can occur by June 30, 2024, this is acceptable to MassDEP. If you would like to discuss further, or have any other questions, please give me a call.

Thank you,
--Mark

*Mark Fairbrother, Solid Waste Section Chief | phone (617) 780-2356
MassDEP-NERO | 150 Presidential Way, Suite 300 | Woburn, MA 01801*

From: Paul Sevigny <psevigny@wnewbury.org>
Sent: Thursday, January 25, 2024 11:47 AM
To: Fairbrother, Mark (DEP) <mark.fairbrother@mass.gov>
Subject: RE: West Newbury/Steele Landfill - updated monitoring requirements - PFAS

CAUTION: This email originated from a sender outside of the Commonwealth of Massachusetts mail system. Do not click on links or open attachments unless you recognize the sender and know the content is safe.

Hi Mark,

The cost for the PFAS testing has come in much higher than we anticipated. We may not have the funds until May or June to conduct these extra tests. Is that going to be a problem with MA DEP?

From: Fairbrother, Mark (DEP) <mark.fairbrother@mass.gov>
Sent: Tuesday, November 28, 2023 12:59 PM
To: Paul Sevigny <psevigny@wnewbury.org>
Subject: RE: West Newbury/Steele Landfill - updated monitoring requirements - PFAS

Good afternoon, Paul –

As discussed during our call today, it is preferable to complete the private well monitoring during the next scheduled event for the routine landfill monitoring (Spring 2024). MassDEP appreciates the Town's attention to this work. If you have any questions, please let me know.

Thanks again,
--Mark

*Mark Fairbrother, Solid Waste Section Chief | phone (617) 780-2356
MassDEP-NERO | 150 Presidential Way, Suite 300 | Woburn, MA 01801*

From: Paul Sevigny <psevigny@wnewbury.org>
Sent: Wednesday, November 22, 2023 10:23 AM
To: Fairbrother, Mark (DEP) <mark.fairbrother@mass.gov>
Subject: RE: West Newbury/Steele Landfill - updated monitoring requirements - PFAS

CAUTION: This email originated from a sender outside of the Commonwealth of Massachusetts mail system. Do not click on links or open attachments unless you recognize the sender and know the content is safe.

Hi Mark,

We are working on gathering prices for the new PFAS testing requirement. Our current schedule is to test the residential wells in October 2024. Can we still hold this time frame or do we need to test the private wells the same time we test the landfill GW wells (April 24). The reason why I ask is for budgetary consideration because it's a different fiscal year and will definitely make a difference in the budgeted amount.

From: Fairbrother, Mark (DEP) <mark.fairbrother@mass.gov>

Sent: Monday, October 30, 2023 3:11 PM

To: Paul Sevigny <psevigny@wnewbury.org>

Cc: Kane, Patrick (DEP) <Patrick.Kane2@mass.gov>; Morey, John (DEP) <john.morey@mass.gov>

Subject: West Newbury/Steele Landfill - updated monitoring requirements - PFAS

Paul,

Attached is a letter regarding the updated monitoring requirements for the Steele Landfill (West Newbury) that we discussed earlier today.

Please contact MassDEP with any questions.

Thank you,

--Mark

*Mark Fairbrother, Solid Waste Section Chief | phone (617) 780-2356
MassDEP-NERO | 150 Presidential Way, Suite 300 | Woburn, MA 01801*

Town Manager

From: Town Manager
Sent: Thursday, January 25, 2024 10:30 AM
To: Paul Sevigny; Town Accountant
Cc: Rob Phillips (rob-phillips@verizon.net); Executive Assistant
Subject: RE: Reserve Fund Transfer
Attachments: 20240125093515859.pdf

Paul,
Have you asked MDEP if they would consider testing in late April or May of 2024 to be responsive to the spring 2024 testing requirement? If so, this funding request could be placed on the STM warrant with funds – assuming approval – available on April 30th. This would be important for the FinCom to understand since the request represents more than half of the budgeted FY24 reserve fund.

I have copied FinCom Chair Rob Phillips here and would ask Rob that you please place the BOH request on the next FinCom agenda.

Thanks,
Angus

Angus Jennings, Town Manager
Town of West Newbury
Town Office Building
381 Main Street
West Newbury, MA 01985
(978) 363-1100 x111
townmanager@wnewbury.org

From: Paul Sevigny <psevigny@wnewbury.org>
Sent: Thursday, January 25, 2024 9:48 AM
To: Town Accountant <townaccountant@wnewbury.org>
Cc: Town Manager <townmanager@wnewbury.org>; Executive Assistant <exec.assistant@wnewbury.org>
Subject: Reserve Fund Transfer

Good Morning,

Please find attached the BOH request for a reserve fund transfer for the Steele Landfill. Any questions, please let me know.

Paul Sevigny, Health Agent
Town of West Newbury
381 Main Street
West Newbury, MA 01985
978-363-1100, x119

**TOWN OF WEST NEWBURY
REQUEST FOR TRANSFER FROM THE RESERVE FUND**

Fiscal Year: FY24

Date: January 25, 2024

To: Finance Committee

From: Board of Health

- 1) In accordance with Chapter 40, Section 6, of the Massachusetts General Laws, it is requested that \$ 22,915 be transferred from the Reserve Fund to the following account: 01-510-5293.
- 2) A total of \$ 36,915 has been appropriated for or transferred to the above account during the current fiscal year.
- 3) A list of all expenditures made or obligations incurred against the above account during the current fiscal year is attached.
- 4) The unobligated balance of the above account as of the date of this request is \$ 0.
- 5) The amount requested is needed to Comply with MA DEP's PFAS testing requirement
- 6) The need for the amount requested was unforeseen because MA DEP required this in a letter dated October 30, 2023
- 7) Funding of this request cannot wait until the next ATM because MA DEP requests that the testing be conducted in the spring of 2024

The undersigned will meet with the Finance Committee to discuss this request at its regular meeting scheduled upon request.

Signed: 
Robert P. James BOH Chair

Signed: _____
Town Accountant

Finance Committee Action:

Date: _____

Number of Committee Voting: _____

The requested transfer of \$ _____ from the Reserve Fund to the Account is Approved Denied

If not approved, the rationale for the Committee's action was: _____

Signed: _____
Chairman, West Newbury Finance Committee

Steele Landfill Reserve Fund Transfer Information (1/25/24)

The original landfill budget was approved at \$36,315. A month into the fiscal year we learned that our monthly gas testing was going to increase \$50/month (total increase of \$600). This was brought to the BOH and the Town Manager attention. Ultimately \$600 was added to our budget at the October 2023 Town meeting, for a new budget total of **\$36,915**.

On October 30, 2023, we were notified by MA DEP that we needed to test the landfill & residential wells for the presence of PFAS. This would not need to occur until Spring of 2024. This new requirement was relayed to the BOH & Town Manager.

On November 28, 2023 via email MA DEP asked us to test the private wells during the Spring of 2024, rather than October 2024 (FY25) as originally planned.

The biannual testing of the groundwater for FY24 has also increased slightly due to increases analytical costs.

The budget increases for FY24 is as follows:

Biannual GW and surface waters increased **\$485**

New PFAS testing requirement for the GW & surface waters **\$7,020**

Private well testing for PFAS **\$12,220**

Private well testing for 1,4 – Dioxane **\$3,190**

Revised FY24 budget needed \$59,830

Approved FY24 budget (\$36,315) + (\$600) = \$36,915

Total Reserve Fund Transfer needed to complete the required landfill testing for FY24
\$22,915



Commonwealth of Massachusetts
Executive Office of Energy & Environmental Affairs

Department of Environmental Protection

Northeast Regional Office • 150 Presidential Way Woburn, MA 01801 • 978-694-3200

Maura T. Healey
Governor

Kimberley Driscoll
Lieutenant Governor

Rebecca L. Tepper
Secretary

Bonnie Heiple
Commissioner

October 30, 2023

West Newbury Board of Health
381 Main Street
West Newbury, MA 01985

Attention: Paul Sevigny

RE: WEST NEWBURY – Solid Waste Management
Steele Landfill
Middle Street/Georgetown Road
SMS Number: 39872

**Updated Requirements for
Landfill Environmental Monitoring**

Dear Mr. Sevigny:

The Massachusetts Department of Environmental Protection, Northeast Regional Office, Bureau of Air and Waste, Solid Waste Management Section (MassDEP) is issuing this correspondence to the Town of West Newbury (the Town) regarding the Town's closed and capped Steele Landfill located at the corner of Middle Street and Georgetown Road in West Newbury, MA (the Landfill).

The Landfill is currently in post-closure status, pursuant to a Closure Certification Approval issued by MassDEP in May 1995, with an updated environmental monitoring program approved by MassDEP on October 31, 2018. The current monitoring program for the Landfill includes, but is not limited to, semi-annual collection and analysis of water samples from on-site groundwater monitoring wells and surface water locations, as well as the collection and analysis of water samples from private potable wells every three years that serve the residences located at 20, 24, and 37 Middle Street, and 115, 116, 118, and 120 Georgetown Road in West Newbury.

As part of MassDEP's ongoing statewide efforts to address Per- and Polyfluoroalkyl Substances (PFAS), MassDEP and other federal and state environmental agencies have become aware that municipal solid waste landfills are potential sources of PFAS in groundwater and surface water.

Per & Polyfluoroalkyl Substances

Per- and polyfluoroalkyl substances ("PFAS") are a family of chemicals used since the 1950s to manufacture stain resistant, water resistant, and non-stick products. PFAS are widely used in common consumer products as coatings, on food packaging, outdoor clothing, carpets, leather goods, ski, and snowboard waxes, and more. Certain types of firefighting foam historically used by the U.S. military, local fire departments, and airports to fight oil and gasoline fires may contain PFAS. Landfills can be

This information is available in alternate format. Please contact Melixza Esenyie at 617-626-1282.

TTY# MassRelay Service 1-800-439-2370
MassDEP Website: www.mass.gov/dep

Printed on Recycled Paper

sources of PFAS because they are the ultimate repositories for PFAS-contaminated industrial waste, sewage sludge from wastewater treatment facilities, and waste from site mitigation, as well as for PFAS-bearing consumer wastes.

Because PFAS are water soluble and highly resistant and, PFAS from firefighting foams, manufacturing sites, landfills, spills, air deposition from factories and other releases can seep into surface soils. From there PFAS can leach into groundwater and surface water and result in contamination of drinking water as well as impacts to fish and wildlife.

PFAS Regulations/Standards

On December 13, 2019, the MassDEP revised the Massachusetts Contingency Plan (MCP) to include Reportable Concentrations and cleanup standards for soil and groundwater to address sites contaminated with PFAS. On October 2, 2020, the MassDEP published its PFAS drinking water standard or Massachusetts Maximum Contaminant Level (“MMCL”) of 20 nanograms per liter (“ng/L”), or parts per trillion (“ppt”) applicable to community (“COM”) and non-transient non-community (“NTNC”) systems for the sum of the concentrations of six (6) specific PFAS (“PFAS6”). The Massachusetts Drinking Water Regulations, 310 CMR 22.00 (“Drinking Water Regulations”) were revised to reflect these requirements. This drinking water standard is set to be protective against adverse health effects for all people consuming water containing PFAS6. The six (6) specific PFAS are:

- Perfluorodecanoic Acid (“PFDA”)
- Perfluoroheptanoic Acid (“PFH_pA”)
- Perfluorohexanesulfonic Acid (“PFH_sS”)
- Perfluorononanoic Acid (“PFNA”)
- Perfluorooctanesulfonic Acid (“PFOS”)
- Perfluorooctanoic Acid (“PFOA”)

MassDEP maintains an up-to-date public outreach website for PFAS issues at the following address:
<https://www.mass.gov/info-details/per-and-polyfluoroalkyl-substances-pfas>

This letter is to alert the Town of West Newbury that MassDEP is now requiring sampling and analysis for PFAS compounds as part of the Landfill’s environmental monitoring plan. This letter requires the Town of West Newbury to include sampling and analysis for PFAS compounds in the upcoming environmental monitoring event for the Landfill, scheduled in Spring 2024. MassDEP has the authority to require such sampling and analysis for PFAS compounds based on 310 CMR 19.132(2)(h), which states that “...at a minimum, the owner or operator shall analyze surface and ground water samples for the following parameters [a list then follows], unless otherwise approved by the Department based on review of past monitoring results or other relevant information ... and, (4) any additional parameters required by the Department.”

CONDITIONS

1. Beginning with the next environmental monitoring event (scheduled for Spring 2024), the Town of West Newbury shall include sampling and analysis for PFAS, together with all other required parameters, at each groundwater monitoring well, surface water/leachate sampling location specified in the October 31, 2018 approval, and the private wells that serve the residences located at 20, 24, and 37 Middle Street, and 115, 116, 118, and 120 Georgetown Road in West Newbury. Thereafter, The Town shall continue to conduct PFAS monitoring during each landfill

environmental monitoring event in accordance with the Landfill's ongoing environmental monitoring plan and the requirements of this letter, unless and until MassDEP approves in writing a request supported with adequate data for a reduction in such monitoring.

2. PFAS monitoring shall include sampling for Per- and Polyfluoroalkyl Substances, with laboratory analysis by EPA Method 537.1 for the full list of method analytes. PFAS sampling shall be performed as outlined in the MassDEP's June 2021 *Field Sampling Guide for PFAS*. (Internet link: <https://www.mass.gov/doc/field-sampling-guide-for-pfas/download>).
3. PFAS analyses shall be performed by laboratories that are approved by MassDEP pursuant to 310 CMR 42.000: *Certification and Operation of Environmental Analysis Laboratories*.
4. The MMCL standard of 20 ng/l (parts-per-trillion) is for the sum of six specified PFAS compounds: perfluorooctane sulfonic acid (PFOS); perfluorooctanoic acid (PFOA); perfluorohexane sulfonic acid (PFHxS or PFSxS); perfluorononanoic acid (PFNA); perfluoroheptanoic acid (PFHpA), and perfluorodecanoic acid (PFDA). When some, or all, of these compounds occur together in drinking water, the detected concentrations for these PFAS compounds should be summed and compared to the MCL.
5. For each private well, samples of potable water shall be collected both before and after any water filtration/treatment, if present. The summary report accompanying the analytical results shall clearly indicate if filtration/treatment is present at each residence.
6. The results of the environmental monitoring required above shall be submitted to MassDEP and to the West Newbury Board of Health within 60 days of the date of sampling, in accordance 310 CMR 19.132. In addition:
 - a. The Town or its consulting engineer shall notify MassDEP of any exceedances of any regulatory standards within the applicable notification periods pursuant to the Massachusetts Contingency Plan at 310 CMR 40.0000 (i.e., within 2 hours if PFAS6 detected in a private drinking water well is equal to or greater than the RCGW-1 reportable concentration of 20 ppt, or within 72 hours if PFAS6 is detected in groundwater within 500 feet of a private water supply well at a concentration equal to or greater than the RCGW-1 reportable concentration of 20 ppt), the Solid Waste Management regulations at 310 CMR 19.000; or if no other regulatory standard applies, within 7 days of obtaining knowledge of the condition.
 - b. The Town shall provide copies of analytical results to the private well owner and occupants of properties served by the private well within 60 days of the date of sampling.
 - c. If analytical results exceed regulatory standards in private drinking water samples, the Town shall take remedial steps necessary to protect public health and safety, as required by MassDEP pursuant to 310 CMR 19.000.
 - d. The Town shall comply with the requirements at 310 CMR 40.0114 for the site to be deemed adequately regulated pursuant to 310 CMR 40.0000, the Massachusetts Contingency Plan. The Town shall comply with the requirements of 310 CMR 40.0000, the Massachusetts Contingency Plan including, but not limited to, section 310 CMR 40.0114: *Solid Waste Management Facilities*.

7. If the owners or occupants of any of the residences with private wells decline to grant access for sampling purposes, the Town shall provide to MassDEP written documentation of both the request and the refusal.
8. These requirements do not otherwise supersede or alter any other provisions of the monitoring requirements specified in the October 31, 2018 approval.

MassDEP understands you may have questions or need technical assistance on incorporating PFAS compounds into the environmental monitoring plan for the Landfill. If you have any questions concerning this matter, please email John Morey at john.morey@mass.gov.

Sincerely,

This final document copy is being provided to you electronically by the Department of Environmental Protection. A signed copy of this document is on file at the DEP office listed on the letterhead.

Mark G. Fairbrother
Section Chief
Solid Waste Management

John P. Morey
Environmental Analyst
Solid Waste Management

MGF/JPM/jpm

Enclosure: Communication for Non-English-Speaking Parties

cc: West Newbury Board of Health
Email: psevigny@wnewbury.org

John H. Clement
New England Environmental Technologies Corporation
145 South Main Street
Haverhill, MA 01835

Landfill Monitoring Schedule

Reserve Fund Transfer Request

FY24 Budget as needed to comply with DEP's PFAS requirement (revised 1/25/24)

FY24	GW Monitoring Well & Surface Water Sampling (2x Year)*	PFAS testing within the Landfill	Gas Vent (GV) & GMP Testing (12x Year)	Notes:	Wildlife Control & Maintenance	PFAS testing (private wells)	Private Well Testing 1,4-Dioxane (Every 3 Years) 2024, 2027, 2030	Third Party Inspection (Every 2 Years) 2024, 2026, 2028, 2030	Notes:	Totals
Jul-23			\$ 1,600.00							\$ 1,600.00
Aug-23			\$ 1,600.00							\$ 1,600.00
Sep-23			\$ 1,600.00							\$ 1,600.00
Oct-23	\$ 7,650.00		\$ 1,600.00							\$ 9,250.00
Nov-23			\$ 1,600.00							\$ 1,600.00
Dec-23			\$ 1,600.00							\$ 1,600.00
Jan-24			\$ 1,600.00							\$ 1,600.00
Feb-24			\$ 1,600.00							\$ 1,600.00
Mar-24			\$ 1,600.00							\$ 1,600.00
Apr-24	\$ 7,850.00	\$ 7,020.00	\$ 1,600.00		\$ 1,500.00	\$ 12,220.00	\$ 3,190.00			\$ 33,380.00
May-24			\$ 1,600.00							\$ 1,600.00
Jun-24			\$ 1,600.00					\$1,200		\$ 2,800.00
SUB TOTAL										\$ 59,830.00
GRAND TOTALS	\$ 15,500.00	\$ 7,020.00	\$ 19,200.00		\$ 1,500.00	\$ 12,220.00	3190	\$ 1,200.00		\$ 59,830.00

FY24



Group as: **_***_****_*****

Parameters: Fiscal Year: 2024 Start Date: 7/1/2023 end: 6/30/2024

Ledger History - Allocated Summary - Expenditure Ledger

Account Number	Name	Allocated	Expended	Ending	% Var.
Group 1: Segment 2: Department		Code: 510 - Board of Health			
01-510-5111-000000	Board of Health Salary & Wages	134,918.00	0.00	134,918.00	0.00
01-510-5200-000000	Public Health Nurse	6,000.00	0.00	6,000.00	0.00
01-510-5290-000000	Waste Collection	421,400.00	0.00	421,400.00	0.00
01-510-5291-000000	Recycling	45,000.00	0.00	45,000.00	0.00
01-510-5292-000000	Hazardous Waste Expenses	2,000.00	0.00	2,000.00	0.00
01-510-5293-000000	Steele Landfill Monitoring	* 36,315.00	0.00	36,315.00	0.00
01-510-5400-000000	Bd of Health Expenses	7,000.00	0.00	7,000.00	0.00
26-510-5900-000000	Septic Title 5 Repaymt WPAT	10,364.00	0.00	10,364.00	0.00
Total Group 1: Segment 2: Department		662,997.00	0.00	662,997.00	0.00

* Landfill amended October 2023
+ \$600 for testing



January 16, 2024
Proposal: P-3437

Mr. Paul Sevigny
West Newbury Board of Health
381 Main Street
West Newbury, MA 01985

Re: *Steele Landfill, Middle Street, West Newbury, MA*
FY 2024 Semi-Annual Environmental Sampling for PFAS Compounds

Dear Mr. Sevigny,

In a correspondence dated October 30, 2023, the Massachusetts Department of Environmental Protection (MADEP) notified the West Newbury Board of Health that the current environmental monitoring program associated with the inactive Steele Landfill is required to be updated to include the sampling and analysis of groundwater and surface water samples for PFAS compounds.

New England Environmental Technologies Corporation (NEET) is pleased to provide you with this proposal for services relating to one (1) semi-annual sampling and analysis event for the presence of PFAS compounds within water samples gathered from five (5) on-site monitoring wells and two (2) surface water locations at the Steele Landfill. This PFAS sampling event represents the first semi-annual sampling scheduled to occur within April or May of calendar year 2024. Groundwater sampling shall be conducted in accordance with specific PFAS protocols as established by the MADEP. The analytical protocol employed shall be capable of detecting and reporting the contaminant of concern (COC) to a concentration equal to or less than the drinking water standard of 20 part per trillion (ppt) for PFAS compounds as established by the MADEP.

The samples will be forwarded to a Massachusetts Certified Laboratory under a detailed chain of custody procedure. All sampling and analytical reports will be accompanied by a QA/QC information package. The analytical results will be made available to the Town of West Newbury within 30 days of sample collection. The reported data will be summarized in a tabulated format.

This scope of service includes the personnel, equipment and analytical procedures necessary to complete the stated project objective.



January 16, 2024
Proposal: P-3437

The analytical results will be made available to the Town of West Newbury within 30 days of sample collection. The reported data will be summarized in a tabulated format and will include a site plan indicating monitoring well designations and surface water sampling locations. Static groundwater elevations will be recorded prior to groundwater sampling and will be accompanied with pertinent field QQ/QC documentation and chain of custody forms.

This quotation and commitment if consummated are limited to the scope of services as outlined and does not encompass the cost associated with an expanding work effort involving additional assessment or remedial activities, DEP reporting and/or notification, or additional sampling and analysis activities which may be deemed necessary in the formulation of a sound professional opinion pertaining to site status. Changes in work scope, if necessary, will be conducted only with the client's express knowledge and consent.

Sincerely,

John Clement
President



January 16, 2024
Proposal: P-3437

Mr. Paul Sevigny
West Newbury Board of Health
381 Main Street
West Newbury, MA 01985

**Re: *Steele Landfill, Middle Street, West Newbury, MA
FY 2024 Semi-Annual Environmental Sampling for PFAS Compounds***

This Proposal for Services and the Statement of Terms and Conditions are hereby accepted and executed by a duly authorized signatory, who by execution hereof, warrants that he/she has full authority to act for, in the name, and on behalf of Client. The signatory to this contract having read, understood and accepted this work scope and enclosed Terms & Conditions hereby provides his/her personal guaranty of timely payment to NEET Corporation for the full amount of the project cost in the event of non-payment or default for whatever reason, if this contract is executed on behalf of, in the name of, or for a corporate entity or trust.

Corporate Name: _____

Signature _____ Title _____

Printed Name _____ Date _____

Field & Report Services	\$1,700.00
Analytical Services	\$ 5,320.00
Less 50% deposit	Waived
Balance due upon completion of work scope	\$7,020.00

<<<<<< PRICE QUOTES VALID FOR 30 DAYS >>>>>>

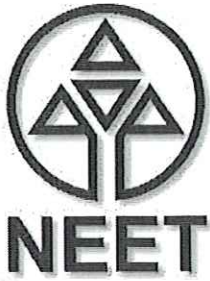

January 16, 2024
Proposal: P-3438

Mr. Paul Sevigny
West Newbury Board of Health
381 Main Street
West Newbury, MA 01985

Re: *Steele Landfill, Middle Street, West Newbury, MA*
FY 2024 Semi-Annual Environmental Sampling

Dear Mr. Sevigny,

New England Environmental Technologies Corporation (NEET) is pleased to provide you with this proposal for services relating to one (1) semi-annual sampling and analysis event of groundwater to be gathered from on-site monitoring wells located at the Steele Landfill. If accepted, the proposed services will represent the second round of the FY2024 semi-annual sampling and analysis of groundwater at the Steele Landfill. This sampling event will be scheduled to occur within April-May of 2024.

The purpose of this effort is to provide current water quality data in terms of the current monitoring standards as referenced at 310 CMR 19.132(1)(h). Groundwater sampling shall be conducted in accordance with methods approved by the MADEP. The sampling points have been previously established and will consist of five (5) groundwater monitoring wells and two (2) surface water locations. In the event that the established sampling points are inaccessible, alternate locations may be used if available. The samples will be obtained from groundwater monitoring wells that currently exist at the landfill. The boring and well construction logs for the wells to be utilized in this sampling effort have been previously submitted to the MADEP. All sampling and analytical reports will be accompanied by a QA/QC information package. Samples will be obtained using appropriate protocols and properly preserved. The samples which require off site analysis will be forwarded to a Massachusetts Certified Laboratory under a detailed chain of custody procedure.

The analytical results will be made available to the Town of West Newbury within 30 days of sample collection. The reported data will be summarized in a tabulated format and will include a site plan indicating monitoring well designations and surface water sampling locations. Static groundwater elevations will be recorded prior to groundwater sampling and will be accompanied with pertinent field QQ/QC documentation and chain of custody forms.



January 16, 2024
 Proposal: P-3438

This scope of service includes the personnel, equipment and analytical procedures necessary to complete the stated project objective. The analytical parameters that are to be addressed within this scope of work are tabulated below for your reference. The suite of parameters referenced at 310 CMR 19.132(1)(h) are listed as follows:

Indicator Parameters		Dissolved Inorganics	
pH	In Situ	Arsenic;	
Alkalinity		Barium;	
Temperature	In Situ	Cadmium;	
Specific Conductance	In Situ	Chromium	
Nitrate Nitrogen		Copper	
Total Dissolved Solids		Cyanide;	
Chloride		Lead;	
Calcium		Mercury;	
Sodium		Selenium;	
Iron		Silver;	
Manganese		Zinc.	
Sulfate			
Chemical Oxygen Demand			
Dissolved Oxygen	In Situ		

Additionally, water analyses shall include all of the compounds addressed in EPA Method 8260 including methyl ethyl ketone, methyl isobutyl ketone, acetone and 1,4 dioxane (0.2 ug/l detection) and Tentatively Identified Compounds (TICs).

This quotation and commitment if consummated are limited to the scope of services as outlined and does not encompass the cost associated with an expanding work effort involving additional assessment or remedial activities, DEP reporting and/or notification, or additional sampling and analysis activities which may be deemed necessary in the formulation of a sound professional opinion pertaining to site status. Changes in work scope, if necessary, will be conducted only with the client's express knowledge and consent.

Sincerely,

John Clement
 President



January 16, 2024
Proposal: P-3438

Mr. Paul Sevigny
West Newbury Board of Health
381 Main Street
West Newbury, MA 01985

**Re: *Steele Landfill, Middle Street, West Newbury, MA
FY 2024 Semi-Annual Environmental Sampling***

This Proposal for Services and the Statement of Terms and Conditions are hereby accepted and executed by a duly authorized signatory, who by execution hereof, warrants that he/she has full authority to act for, in the name, and on behalf of Client. The signatory to this contract having read, understood and accepted this work scope and enclosed Terms & Conditions hereby provides his/her personal guaranty of timely payment to NEET Corporation for the full amount of the project cost in the event of non-payment or default for whatever reason, if this contract is executed on behalf of, in the name of, or for a corporate entity or trust.

Corporate Name: _____

Signature: _____ Title: _____

Printed Name: _____ Date: _____

Field & Report Services \$2,600.00

Analytical Services \$5,250.00

Less 50% deposit Waived

Balance due upon completion of work scope\$7,850.00

<<<<<< PRICE QUOTES VALID FOR 30 DAYS >>>>>>

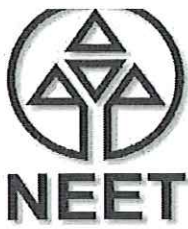

January 16, 2024
Proposal P-3435

Mr. Paul Sevigny
West Newbury Board of Health
381 Main Street
West Newbury, MA 01985

Re: *Steele Landfill, Middle Street, West Newbury, MA*
FY 2024 Potable Water Supply Sampling and Analysis for 1,4-Dioxane

Dear Mr. Sevigny,

New England Environmental Technologies Corporation (NEET) is pleased to provide you with this proposal for services relating to the sampling and analysis of private water supplies located within 500 feet of the Steele Landfill. The purpose of this effort is to provide water quality data specific to 1,4-Dioxane, a common groundwater contaminant.

Groundwater sampling shall be conducted in accordance with methods approved by the MADEP. The analytical protocol employed shall be capable of detecting and reporting the contaminant of concern (COC) to a concentration equal to or less than the drinking water standard of 0.3 ppb for 1,4-Dioxane as established by the MADEP. The West Newbury Board of Health has identified seven (7) individual residential water supplies to be sampled and analyzed for the subject COC.

The samples will be obtained from the individual private water supplies using appropriate protocols and properly preserved. The water samples will be gathered from an access point prior to any water supply filtration or treatment system. The samples will be forwarded to a Massachusetts Certified Laboratory under a detailed chain of custody procedure. All sampling and analytical reports will be accompanied by a QA/QC information package. The analytical results will be made available to the Town of West Newbury within 30 days of sample collection. The reported data will be summarized in a tabulated format.

This scope of service includes the personnel, equipment and analytical procedures necessary to complete the stated project objective.

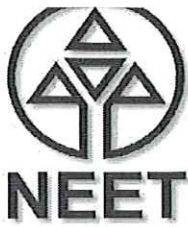

January 16, 2024
Proposal P-3435

This quotation and commitment if consummated is limited to the scope of services as outlined and does not encompass the cost associated with an expanding work effort involving additional assessment or remedial activities, DEP reporting and/or notification, or additional sampling and analysis activities which may be deemed necessary in the formulation of a sound professional opinion pertaining to site status. Changes in work scope, if necessary, will be conducted only with the client's express knowledge and consent.

Sincerely,

John Clement
President



January 16, 2024
Proposal P-3435

Mr. Paul Sevigny
West Newbury Board of Health
381 Main Street
West Newbury, MA 01985

**Re: *Steele Landfill, Middle Street, West Newbury, MA
FY 2024 Potable Water Supply Sampling and Analysis***

This Proposal for Services and the Statement of Terms and Conditions are hereby accepted and executed by a duly authorized signatory, who by execution hereof, warrants that he/she has full authority to act for, in the name, and on behalf of Client. The signatory to this contract having read, understood and accepted this work scope and enclosed Terms & Conditions hereby provides his/her personal guaranty of timely payment to NEET Corporation for the full amount of the project cost in the event of non-payment or default for whatever reason, if this contract is executed on behalf of, in the name of, or for a corporate entity or trust.

Corporate Name: _____

Signature _____ Title _____

Printed Name _____ Date _____

Estimate is based on 7 sampling locations and 7 analyses

Field Services 8 hours @ \$135/hour.	\$1,080.00
Analytical Services 7 @ \$230 each.	\$1,610.00
Summary Report.	\$500.00
Less 50% deposit	Waived
Balance due upon completion of work scope	\$3,190.00

<<<<< PRICE QUOTES VALID FOR 30 DAYS >>>>>



January 16, 2024
Proposal P-3436

Mr. Paul Sevigny
West Newbury Board of Health
381 Main Street
West Newbury, MA 01985

Re: *Steele Landfill, Middle Street, West Newbury, MA*
FY 2024 Potable Water Supply Sampling and Analysis for PFAS Compounds

Dear Mr. Sevigny,

In a correspondence dated October 30, 2023, the Massachusetts Department of Environmental Protection (MADEP) notified the West Newbury Board of Health that the current environmental monitoring program associated with the inactive Steele Landfill was required to be updated to include the sampling and analysis of PFAS compounds at residential water supplies located within 500 feet of the landfill. New England Environmental Technologies Corporation (NEET) is pleased to provide you with this proposal for services relating to the sampling and analysis of the identified private water supplies located within 500 feet of the Steele Landfill.

Groundwater sampling shall be conducted in accordance with methods approved by the MADEP. The analytical protocol employed shall be capable of detecting and reporting the contaminant of concern (COC) to a concentration equal to or less than the drinking water standard of 20 part per trillion (ppt) for PFAS compounds as established by the MADEP. The West Newbury Board of Health has identified seven (7) individual residential water supplies to be sampled and analyzed for the subject COC.

The samples will be obtained from the individual private water supplies using the protocols as established by the MADEP. The sampling protocol requires gathering water samples from before and after residential water treatment systems where present. Each sample must include the analysis of a field blank. The samples will be forwarded to a Massachusetts Certified Laboratory under a detailed chain of custody procedure. All sampling and analytical reports will be accompanied by a QA/QC information package. The analytical results will be made available to the Town of West Newbury within 30 days of sample collection. The reported data will be summarized in a tabulated format.

This scope of service includes the personnel, equipment and analytical procedures necessary to complete the stated project objective.



January 16, 2024
Proposal P-3436

This quotation and commitment if consummated is limited to the scope of services as outlined and does not encompass the cost associated with an expanding work effort involving additional assessment or remedial activities, DEP reporting and/or notification, or additional sampling and analysis activities which may be deemed necessary in the formulation of a sound professional opinion pertaining to site status. Changes in work scope, if necessary, will be conducted only with the client's express knowledge and consent.

Sincerely,

John Clement
President



January 16, 2024
Proposal P-3436

Mr. Paul Sevigny
West Newbury Board of Health
381 Main Street
West Newbury, MA 01985

**Re: *Steele Landfill, Middle Street, West Newbury, MA
FY 2024 Potable Water Supply Sampling and Analysis for PFAS Compounds***

This Proposal for Services and the Statement of Terms and Conditions are hereby accepted and executed by a duly authorized signatory, who by execution hereof, warrants that he/she has full authority to act for, in the name, and on behalf of Client. The signatory to this contract having read, understood and accepted this work scope and enclosed Terms & Conditions hereby provides his/her personal guaranty of timely payment to NEET Corporation for the full amount of the project cost in the event of non-payment or default for whatever reason, if this contract is executed on behalf of, in the name of, or for a corporate entity or trust.

Corporate Name: _____

Signature _____ Title _____

Printed Name _____ Date _____

Estimate is based on 7 sampling locations and 28 analyses

Field Services 8 hours @ \$135/hour.	\$1,080.00
Analytical Services 28 @ \$380 each.	\$10,640.00
Summary Report.	\$500.00
Less 50% deposit	Waived
Balance due upon completion of work scope	\$12,220.00

<<<<< PRICE QUOTES VALID FOR 30 DAYS >>>>>



January 16, 2024
Proposal P-3436

STATEMENT OF TERMS AND CONDITIONS

This Proposal for Services dated above, File No. P-3436, New England Environmental Technologies, Corp. Company") and Client hereby agrees as follows:

Section 1. Services to be Provided. Company hereby agrees to provide Client with the services set forth in the Proposal for Service under the terms and conditions set forth herein.

Section 2. Billing and Payment. Client agrees to pay Company in accordance with the rates and charges set forth in the attached Proposal for Services. **Invoices for Company's services will be as specified within Proposal. All such invoices shall be due and payable upon submission. Client acknowledges and agrees that in the event that timely payment is not made, the overdue balance shall bear interest at 1-1/2 percent per month or the maximum lawful allowable rate as set forth in Company's Invoices. It is further understood and agreed that if Client fails to pay any invoice due to Company within fifteen (15) days after the date of billing, Company, without waiving any other claim or right against Client, and without liability whatsoever to Client, may terminate its performance of services. In addition, it is expressly understood and agreed that client shall pay any and all charges which Company may incur with regard to collection of outstanding balances over sixty days. These charges may include but are not limited to collection agency fees, court costs and/or attorney's fees.**

Section 3. Right of Entry. Client hereby grants to Company or represents and warrants (if the Site is not owned by Client) that permission has been duly granted for a Right of Entry from time to time, by Company, its agents, staff, consultants, and contractors or subcontractor, upon the Site for the purpose of performing and with the right to perform all acts, assessments, and research, including without limitation the making of test borings and other soil compilings, pursuant to the Scope of Services.

Section 4. Subsurface Explorations.

a. Normal Disturbance. Client hereby recognizes that the use of exploration equipment may unavoidably affect, alter, or damage the terrain and affect vegetation, buildings, structures, and equipment in, at, or upon the Site. Client accepts the fact that this is inherent in Company's work and will not hold Company liable or responsible for any such reasonable effect, alteration, or damage. Company will take reasonable precautions to limit damage to Site, but the cost for restoration of damage that may result from our operations has not been included in our fee. If Company is required to restore the land to its former condition, this will be accomplished, and the cost will be added to our fee.

b. Damage to Latent Subterranean Structures. Company will exercise due and reasonable care in locating subterranean structures in the vicinity where proposed subsurface explorations are to be made. This will include contact with appropriate public utilities, review of plans provided by public agencies, and review of plans and information provided by Client and/or the Owner of the Site relating to the location of subterranean structures. Provided Company has proceeded with due and reasonable care, Company cannot be liable for damages or injury arising from damage to or interference with subterranean structures (including, without limitation, pipes, tanks, telephone cables, etc.) which are not called to Company's attention and /or not correctly shown on the plans furnished by Client or others in connection with work performed under this agreement.

Section 5. Sample Disposition. Company will preserve such soil, water, and other samples, if any, obtained from the Site for such period of time as Company in its sole discretion deems appropriate. No such samples will be discarded before thirty (30) days after completion of the Service without prior written notice to Client, provided, however, that samples on which soil or chemical laboratory testing has been performed may be thereafter discarded by Company without such notification. Samples will be available at Company's office for inspection by Client and others authorized by Client; samples will be shipped to a location selected by Client at Client's expense.

Section 6. Standard of Care. Client agrees that Company's services are on behalf of and for the exclusive use of Client for the purposes set forth in the Proposal for Services. Client recognizes that Company's services require decisions which are not based upon pure science but rather upon judgmental considerations. Company will perform services in accordance with generally accepted practices of environmental engineers/scientists undertaking similar Assessments in the same locale under like or identical circumstances. Client agrees that such services will be rendered without any other warranty, express or implied.



January 16, 2024
Proposal P-3436

Section 7. Documents. All reports, boring logs, field data, field notes, laboratory test data, calculations, estimates, and other documents prepared by Company as instruments of service shall remain the property of Company. Client agrees that all reports and other work furnished to Client or its agents shall be utilized by Client solely for the intended purposes of the Service. Company will retain all pertinent records relating to the services performed for a period of five (5) years following submission of the report of the Service, during which period the records will be made available to Client at Company's office at all reasonable times. Copies will be prepared by Company for Client for reasonable cost of reproduction/transmittal.

Section 8. Charge of Site. Company, by virtue of providing the services described in the Proposal for Services, does not assume the responsibility of the person in charge of the Site, or otherwise undertake responsibility for reporting to any federal, state, or local public agencies any conditions at the Site that may present a potential danger to public health, safety, or the environment. Client acknowledges that it is Client's responsibility to notify the appropriate federal, state, or local public agencies as required by law, or otherwise to disclose, in a timely manner, any information that may be necessary to prevent any danger to public health, safety, or the environment.

Section 9. Confidentiality. Company will not intentionally divulge information regarding its services other than to parties designated by Client in writing. Information that is in the public domain or is provided to Company by third parties is excepted from the foregoing. Notwithstanding the above, Company will exercise its best efforts to comply with federal, state, county, and municipal laws, regulations, ordinances, and legal obligations regarding the reporting of findings to appropriate public agencies. Client agrees to hold Company harmless against any and all claims, demands, suits, or liabilities resulting from such actions by Company.

Section 10. Client's Duty to Notify of Hazards. Client agrees to advise Company promptly of any hazardous substances or any condition known by Client to exist in, on, or near the Site presenting a potential danger to human health or the environment. If Client fails to advise Company or, notwithstanding such advice, unanticipated occurrences of such substances or conditions are discovered during the course of the work, and such discovery in the judgment of Company results in or may result in injury or a health risk to persons, whether Company's personnel, Client's personnel, or others, Client agrees that it shall assume full responsibility and liability and shall hold Company harmless from any or all claims, demands, suits, or liabilities for personal injury including disease, medical expenses, including but not limited to continued health monitoring and/or death, property damage, and economic loss, including consequential damages.

Section 11. Hazardous Waste Disposal. Client specifically agrees to defend, hold harmless, and indemnify Company from and against any and all claims and liabilities resulting from:

- a. Client's violation of any federal, state, or local statute, regulation, or ordinance relating to hazardous waste, including without limitation the Resource Conservation and Recovery Act, the Comprehensive Environmental Response Compensation and Liability Act, and Massachusetts General Laws Chapter 21;
- b. Client's direct or indirect undertaking of or arrangement for the treatment, storage, disposal, or transportation of hazardous materials or oil found or identified at the Site;
- c. Changed conditions or waste materials introduced to the Site by Client or third persons after the completion of the study.

Section 12. Disposal of Samples. In the event that samples collected from the Site contain substances defined as hazardous by federal, state, or local statutes, regulations, or ordinances, Company will either (i) dispose of such samples by contract with a qualified waste disposal contractor; or (ii) will ship such samples to a location selected by Client for final disposal. Client agrees to pay all costs associated with the storage, transport, and disposal of samples. In the event any sample must be stored by Company for a period in excess of thirty (30) days, Client agrees to pay an additional fee charged in accordance with the Company's standard laboratory schedule.

Section 13. Collection Expense; Attorney's Fees. If Company is required to assign any claim involving this contract for collection and/or to institute legal action to enforce this agreement and/or recover possession of any of Company's equipment, client agrees to pay (in addition to any sum payable under the contract) the reasonable costs and expenses incurred by Company, including attorney fees, court costs, and the fair market value for any time during which any principal, employee or agent of the Company pursues recovery of Company's equipment or collection of fees due under the terms of the contract.



Town of West Newbury
SLFRF - State and Local Fiscal Recovery Funds ARPA
Project Request Form

Please complete this form and attach any additional paperwork to support your request.

Date:	11/1/2023
Project Name:	Vertical Turbine Pump #1
Project ID: (accounting use only)	
Expense Category:	Material/Outside Contractors
Description of Project: (50-250 words)	Pump #2 was removed and reinstalled. At this time they found pump #1 was not functioning due to it being in service for more than 12 years. It needs to be replaced before the next budget cycle. See attached documents showing condition and the proposal. \$16,374 plus any unforeseen issues
Estimated Project cost	\$20,000
Status of completion:	
Which FY will these expenses occur:	2024

Dept head approval/Date

Mark A. McHugh 11/1/23

Select Board approval/Date

Accounting approval/Date



71 Concord Street
North Reading, MA 01864
Tel: 978-664-WELL (9355) Fax: 978-664-9356
www.maherserv.com

10/26/2023

Mark Marlowe
West Newbury Water Dept.
381 Main Street
West Newbury, MA 01985
water.superintendent@wnewbury.org

Proposal No.: MS-5415

**RE: Pump #1
West Newbury, MA**

Dear Mark,

We are pleased to submit this proposal for the above referenced project. Maher Services, Inc, (MSI), 71 Concord Street, North Reading, MA 01864, will be providing services to West Newbury Water Department (CLIENT) for the project referred to as Pump #1, West Newbury, MA per attached pricing sheet.

Scope of Work:

We propose to pull pump #1 and bring back all equipment to our shop to be steam cleaned, disassembled, and inspected. After inspection we will provide a report detailing the condition of the pump and equipment and a cost estimate for any needed repairs. Access to the pump must be provided by the owner.

For budget purposes we have provided repair costs based on the work completed on Pump #2.

Prices are good for 10 days from the date of this proposal and are based upon Massachusetts Prevailing wage rates. Payment are net 30 days and interest will be charged at the rate of 1-1/2% per month on any balance that remains unpaid thirty (30) days after the date of invoice. The pricing and scope of work is based upon information provided to MSI and is an estimate only.

Site access is to be provided and maintained by CLIENT in a condition suitable for MSI's equipment. MSI is not responsible for damage to paved, grassed, or landscaped areas. MSI is not responsible for materials and items not specifically enumerated in the proposal/contract. MSI is not responsible for Federal, state or local permits and/or taxes.

Our Contract Terms and Conditions are attached hereto and by this reference incorporated into the contract. In order to proceed, please return a signed copy of the proposal along with an initialed copy of the Contract Terms and Conditions.

If you need further information, please contact us.

Sincerely,
MAHER SERVICES, INC.



Peter Maher
pmaher@maherserv.com

PROPOSAL # MS-5415

Accepted and Agreed:

CLIENT: West Newbury Water Department

By: _____
(Signature)

Name: _____
(Please Print)

Title: _____
(Please Print)

The above individual represents that he/she is authorized to execute this contract on behalf of the CLIENT. MSI Contract Terms and Conditions must be initialed and returned with this contract.

NO WORK ON THE PROJECT WILL COMMENCE UNTIL MSI RECEIVES AND ACCEPTS THE SIGNED PROPOSAL/CONTRACT AND CONTRACT TERMS AND CONDITIONS IN THEIR ENTIRETY. IF ACCEPTED AN EXECUTED COPY WILL BE RETURNED TO YOU.

ACCEPTED BY AUTHORIZED REPRESENTATIVE

MAHER SERVICES, INC.

By: _____

Title: _____

Date: _____

Maher Services, Inc.

71 Concord Street
 North Reading, MA 01864
 Tel: 978-664-WELL (9355) Fax: 978-664-9356

Proposal

MS-5415

<p>10/26/2023</p> <p>Mark Marlowe West Newbury Water Dept. 381 Main Street West Newbury, MA 01985 water.superintendent@wnewbury.org</p>	<p>Project:</p>	<p>RE: Pump #1 West Newbury, MA</p>
---	-----------------	---

Item	Description	Estimated Quantity	Unit Cost	Tax able	Total
1	Crew to remove and reinstall pump #1 via chainfall	1.00 Is	\$ 6,000.00		\$ 6,000.00
2	Steam clean, disassemble and inspect pump. A report detailing the condition of the pump and a cost estimate for any needed repairs will be provided.	1.00 Is	\$ 675.00		\$ 675.00
3	Crew to Clean Pump Can.	1.00 Is	\$ 3,600.00		\$ 3,600.00
			Labor Sum Total		\$ 10,275.00
	New Equipment				
3	New Wolf 7AE8V (140 GPM @ 340' TDH) Vertical Turbine Pump	1.00 ea	\$ 12,029.00		\$ 12,029.00
4	New Chesterton 155 Mechanical Seal	1.00 ea	\$ 2,345.00		\$ 2,345.00
5	(1) - 1" Stuffing Box (2) - 4" x 41-1/2" Black Steel Column Pipe (1) - 1" x 42" 416 SS Line Shaft (1) - 1" x 56-1/2" 416 SS Head Shaft (3) - 1" Line Shaft Couplings (1) - 4" Spider Bearings	1.00 Is	\$ 2,000.00		\$ 2,000.00
			Repairs Sum Total		\$ 16,374.00
	Freight is not included				
	Lead Times: - Wolf Pump / Shafting / Column Pipe = 3 - 5 Days - Mechanical Seal = 5 Days				
	Additional Repairs Necessary after full inspection are not included.				



71 Concord Street
North Reading, MA 01864
Tel: 978-664-WELL (9355) Fax: 978-664-9356
www.maherserv.com

10/26/2023

Mark Marlowe
West Newbury Water Dept.
381 Main Street
West Newbury, MA 01985
water.superintendent@wnewbury.org

**RE: Pump #2 Inspection
West Newbury, MA**

Dear Mark,

Pump #2

Well Can Diameter – 18 inch

Well Depth – 15.3 feet

Pump – Wolf / 7AE8V / 13 stage pump, / 140 GPM @ 340' TDH / Installed Oct. 2023

Motor – US / 20 HP / 460V / 3 PH / 1800 RPM

The existing Goulds 7WAHC 12 stage pump (140 GPM @ 340' TDH) and equipment were disassembled, steam cleaned, and inspected. The pump was plugged with iron and heavily corroded.

All twelve impellers and wear rings were worn beyond acceptable tolerances. Considering the high cost associated with repairing wear rings and impellers on the existing pump, a new Wolf 7AE8V (140 GPM @ 340' TDH) pump was provided and installed. In addition to the impellers and wear rings, the column pipe was heavily corroded with the pipe seams visible. The mechanical seal, stuffing box, head shaft, and line shafts were also worn. The Chesterton mechanical seal was rebuilt. A new head shaft, line shafts and spider bearings were provided and installed.

The 20 HP US motor was left onsite and was not inspected. The existing motor was reinstalled.

Considering the age of pump #1 and that it hasn't received maintenance for a similar period as pump #2, it's likely that the equipment's condition is similar. Therefore, we recommend replacing the equipment for pump #1 as well.





If you need further information, please contact us.

Sincerely,
MAHER SERVICES, INC.

Peter Maher
pmaher@maherserv.com

Company: Premier Pump & Supply, Inc.
 Name: West Newbury, MA
 Date: 09/18/2023

Can Pump



Pump:		
Size:	7AE8V (stages: 13)	Dimensions:
Type:	Multistage	Suction:
Synch Speed:	1800 rpm	Discharge:
Dia:	5.3125 in	Vertical Turbine:
Imp. Material:	BRONZE	Eye Area:
Impeller:	7AE8V - BRZ	Bowl Size:
		Max Lateral:
		Thrust K Factor:

Fluid:			
Name:	Water	Vapor Pressure:	0.256 psi a
SG:	1	Atm Pressure:	14.7 psi a
Density:	62.4 lb/ft ³	Viscosity:	1.1 cP
Temperature:	60 °F	Margin Ratio:	1

Pump Limits:			
Temperature:	120 °F	Sphere Size:	0.29 in
Wkg Pressure:	365 psi g		

Motor:			
Standard:	NEMA	Size:	20 hp
Enclosure:	TEFC	Speed:	1800 rpm
Frame:	256T		
Sizing Criteria:	Design Point		

Search Criteria:			
Flow:	140 US gpm	Near Miss:	---
Head:	340 ft	Static Head:	0 ft

Pump Selection Warnings:
 None

--- Duty Point ---	
Flow:	141 US gpm
Head:	347 ft
Eff:	79.1%
Power:	15.7 hp
NPSHr:	4.19 ft
Speed:	1770 rpm
--- Design Curve ---	
Shutoff Head:	427 ft
Shutoff dP:	185 psi
Min Flow:	--- US gpm
BEP:	79.2% @ 135 US gpm
NOL Power:	17.4 hp @ 173 US gpm
--- Max Curve ---	
Max Power:	18.5 hp @ 175 US gpm

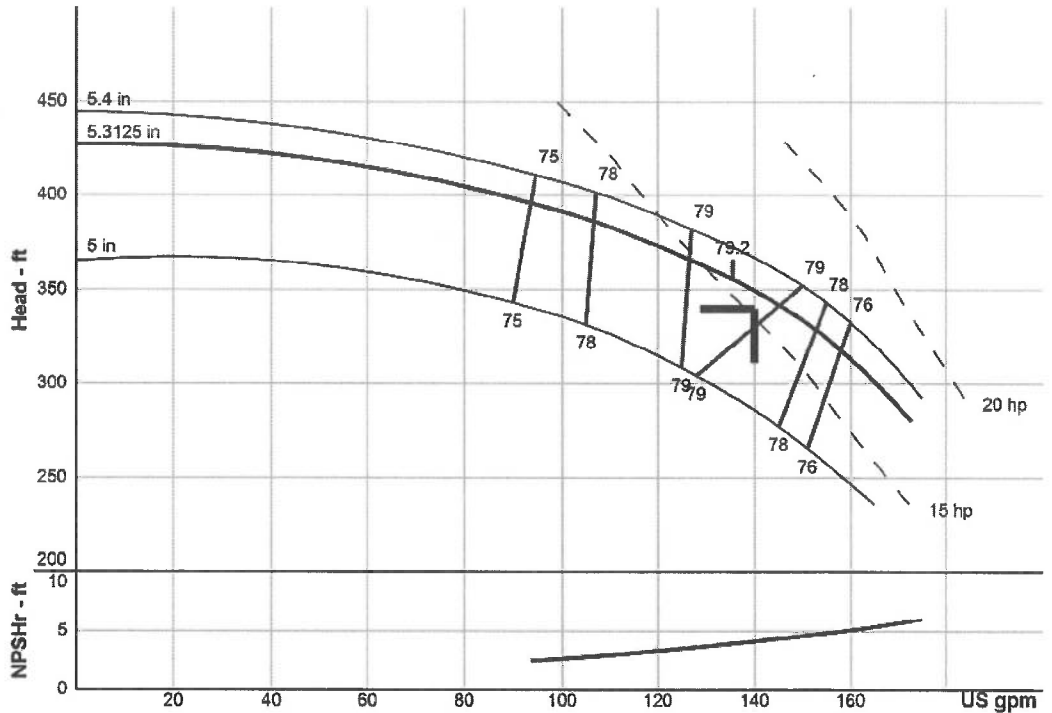

Performance Evaluation:						
Flow	Speed	Head	Efficiency	Power	NPSHr	
US gpm	rpm	ft	%	hp	ft	
168	1770	292	72.1	17.2	5.55	
140	1770	349	79.1	15.6	4.13	
112	1770	381	78.3	13.7	3.03	
84	1770	399	72.8	11.9	2.42	
56	1770	---	---	---	---	

LST CUT SHEET

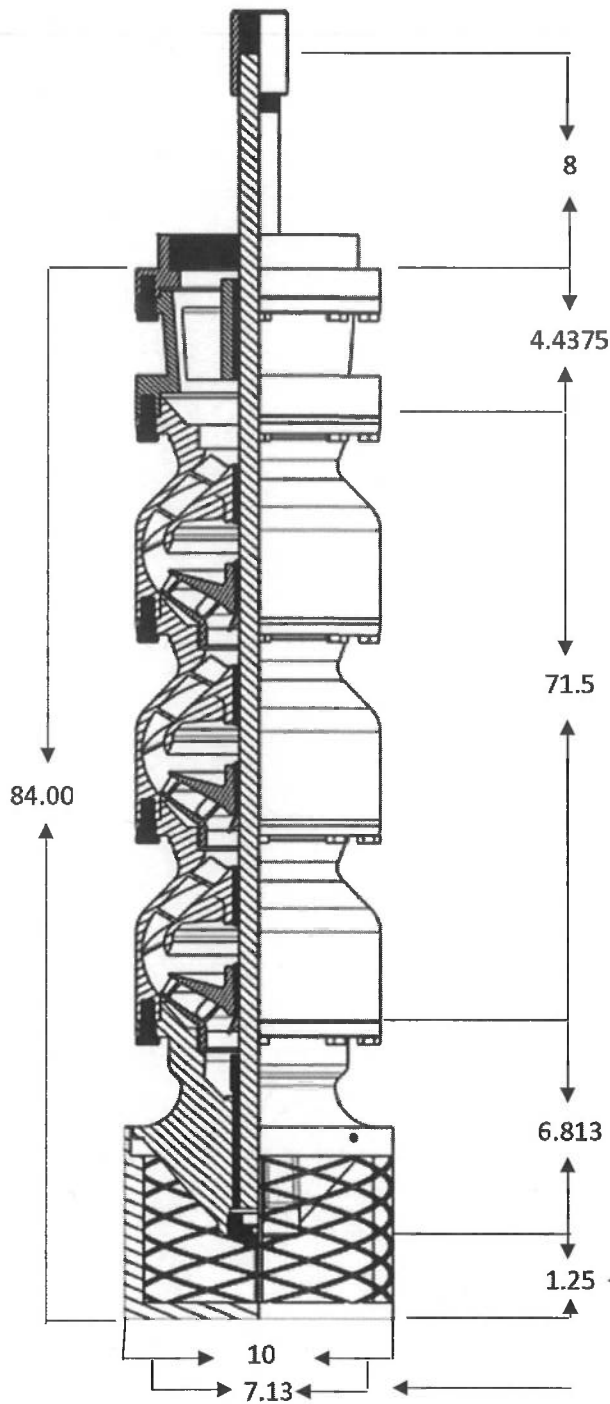

Pump Info	
Pump Model	7AE8V
# stages	13
Weight (LBS) ≈	436
Bowl shaft dia.	1.1875
Stickup	8
Turn down	1"
TPI	10 LH

GPM	140
TDH	340
BHP	15.21

Bowl Connection	18-8SS Bolts
Bowl Material	CI Enamel lined
Impeller Type	Enclosed
Impeller Material	Brass
Shaft	416SS
Collets	SS
Strainer Material	No Strainer
Bearing Material	Mix of Rubber/Brass

If Wolf is not supplying strainer, deduct this length from total length

Max dia w/o strainer

ARTICLE REQUEST FORM

ARTICLE: Coffin Street culverts - design, engineering, permitting

AMOUNT REQUESTED: \$48,213

CONTACT PERSON: Christine Wallace, PE, Projects/Programs Manager

PHONE NUMBER: 978-363-1100 ext. 130

Why should the Town make this purchase? What needs will be met? Who will benefit?

Design, engineering, permitting, procurement for 2 failing/failed culverts on Coffin Street. Intent is to get projects permitted and put out to bid timely to propose construction funding at the Spring 2024 Town Meeting. To date, 3 proposals received (low \$23,000 - high \$73,425). Town is re-scoping project to receive "apples to apples" proposals from prospective vendors. Average of three proposals received (\$48,213) used for budgeting purposes, but this number may be refined during the review process.

What factors affect the timing of this purchase?

The culverts have failed. Replacement (with resizing, as is expected to be recommended) will require local and state permitting, including wetlands delineation, survey and engineering.

When should this Article be sunsetted - how long will the project take?

Goal is to get design and permitting complete by end of FY25

What ancillary costs do you anticipate? (Maintenance, Insurance, Training, etc.)

Once permitted, the culvert replacement costs will likely be brought forward for local funding, unless sufficient grant funds can be secured.

Does this Article involve improvement, preservation or creation of tangible Town-owned assets and projects which 1) have useful life of at least five years; 2) cost over \$20,000 and or 3) for which the Town is authorized to borrow funds? If so, please confirm that this item is on the Capital Improvements Committee Schedule for future capital investments.

Yes

Please attach additional pages or other supporting documentation.

Town of West Newbury Capital Improvement Program - Project Request summary

CIP CODE PGE-012



Date: 1/4/2020 UPDATED 10/28/22 Dept. Priority (1 of 3, etc.): 2
 Department: Department of Public Works Est. Funding Request: \$150,000
 Project Title: Page School Standpipe Installation Est. Useful Life (Years): 50 years
 Contact: Michael Dwyer, Chief Fire Engineer

Previously Presented? Yes No If Yes, when? (FY):

Project Type: Check All That Apply -

Scheduled Replacement	<input type="checkbox"/>	Expanded Service	<input checked="" type="checkbox"/>	Deemed Critical by Dept.	<input checked="" type="checkbox"/>
Present Equipment Obsolete	<input type="checkbox"/>	New Operation	<input checked="" type="checkbox"/>	Regulatory Requirement	<input type="checkbox"/>
Replace Worn-out Equipment	<input type="checkbox"/>	Improved Efficiency/Procedures	<input checked="" type="checkbox"/>	Other	<input type="checkbox"/>
Health and Life Safety	<input checked="" type="checkbox"/>	New Revenue	<input type="checkbox"/>		

Project Description:

To improve the fire suppression of the Page School in case of a structure fire, the Fire Chief has request that a water feed standpipe be installed on the outside of the building and this pipe be connected to the existing fire suppression currently installed in the school. This would also the Fire Department the option of pumping additional water from a pumper truck into the fire suppression system. Recommend hiring a consultant in FY2025 to design and quote system and request funds in FY2026.

Photo (click image to insert):



Project Financing:

Total Project Cost: \$150,000 Stabilization Funding: \$
 Amount & Type of Other Local Funding (ie. CPC, bond, op. budget): \$0 Comments:
 Amount and Type of Non-Local Funding Sources (ie. Grant): \$0 Comments:
Future Costs & Operating Expenses:
 Estimated Annual Cost of Operation & Maintenance \$ Comments:
 Estimated Net Effect on Operating Cost, Revenues, Staffing? \$0 Comments:

Project Planning:

Proposed Start Date of Project: Spring 2024
 How was estimated cost determined? Estimated
 Is Funding Necessary for Further Plans/Estimating? \$30,000 (will be required for design)
 Can the Project be Phased? If yes, expenditure by year

	FY21	FY22	FY23	FY24	FY25	FY26	FY27	FY28	FY29	FY30+	TOTAL
PROPOSED	\$	\$	\$	\$	\$30,000	\$120,000	\$	\$	\$	\$	\$150,000
CIC RECC.	\$	\$	\$	\$	\$	\$	\$	\$	\$	\$	\$
APPROVED	\$	\$	\$	\$	\$	\$	\$	\$	\$	\$	\$

Town of West Newbury Capital Improvement Program - Project Request summary

CIP CODE PGE-009



Date: 1/4/2020, reviewed/confirmed 10/3/23, updated 2/2/24 Dept. Priority (1 of 3, etc.): 1
 Department: Department of Public Works Est. Funding Request: \$665,000
 Project Title: Page School Elevator Replacement Project – Design Only Est. Useful Life (Years): 40 years
 Contact: Brian Richard, Facilities Manager
 Previously Presented? Yes No If Yes, when? (FY): _____

Project Type: Check All That Apply -

Scheduled Replacement	<input checked="" type="checkbox"/>	Expanded Service	<input checked="" type="checkbox"/>	Deemed Critical by Dept.	<input checked="" type="checkbox"/>
Present Equipment Obsolete	<input checked="" type="checkbox"/>	New Operation	<input type="checkbox"/>	Regulatory Requirement	<input type="checkbox"/>
Replace Worn-out Equipment	<input checked="" type="checkbox"/>	Improved Efficiency/Procedures	<input type="checkbox"/>	Other	<input type="checkbox"/>
Health and Life Safety	<input checked="" type="checkbox"/>	New Revenue	<input type="checkbox"/>		

Project Description:
 Both elevators in the Page School are 45 years old and no longer meet the building code requirements and emergency response requirements for a school. These elevators need to be replaced before the end of their service life has expired. The elevator shafts may require enlargement to meet code and cost can be greater than \$600,000. Recommend we hire an engineering consultant to prepare plans and cost estimate of this project prior to requesting construction funds. The consultant would be used to prepare specifications, conduct bidding and inspection of installation.

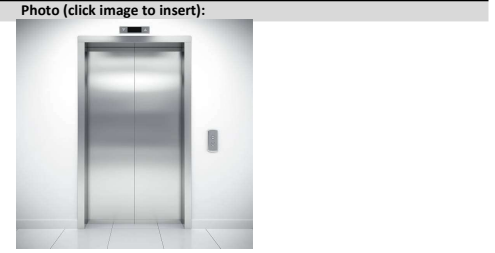

Project Financing:
 Total Project Cost: _____ \$665,000 Stabilization Funding: _____ \$ _____
 Amount & Type of Other Local Funding (ie. CPC, bond, op. budget): _____ \$0 Comments: _____
 Amount and Type of Non-Local Funding Sources (ie. Grant): _____ \$0 Comments: _____

Future Costs & Operating Expenses:
 Estimated Annual Cost of Operation & Maintenance: _____ \$4,000 Comments: _____
 Estimated Net Effect on Operating Cost, Revenues, Staffing? _____ \$0 Comments: _____

Project Planning:
 Proposed Start Date of Project: Spring 2025 Engineering only
 How was estimated cost determined? Estimated cost \$65,000 engineering / \$600,000 construction
 Is Funding Necessary for Further Plans/Estimating? _____
 Can the Project be Phased? If yes, expenditure by year _____

	FY21	FY22	FY23	FY24	FY25	FY26	FY27	FY28	FY29	FY30+	TOTAL
PROPOSED	\$	\$	\$	\$	\$65,000	\$600,000	\$	\$	\$	\$	\$665,000
CIC RECC.	\$	\$	\$	\$	\$	\$	\$	\$	\$	\$	\$
APPROVED	\$	\$	\$	\$	\$	\$	\$	\$	\$	\$	\$

Town of West Newbury Capital Improvement Program - Project Request sumr CIP CODE PGE-020



Date: 10/28/2022, updated 2/4/24 **Dept. Priority (1 of 3, etc.):** 1

Department: School Department **Est. Funding Request:** \$300,000

Project Title: Internal Bus/Car/Ped Site Circulation Improvements **Est. Useful Life (Years):** years

Contact: Angus Jennings, Town Manager

Previously Presented? Yes No **If Yes, when? (FY):**

Project Type: Check All That Apply -

Scheduled Replacement	<input type="checkbox"/>	Expanded Service	<input type="checkbox"/>	Deemed Critical by Dept.	<input checked="" type="checkbox"/>
Present Equipment Obsolete	<input type="checkbox"/>	New Operation	<input type="checkbox"/>	Regulatory Requirement	<input type="checkbox"/>
Replace Worn-out Equipment	<input type="checkbox"/>	Improved Efficiency/Procedures	<input checked="" type="checkbox"/>	Other	<input type="checkbox"/>
Health and Life Safety	<input checked="" type="checkbox"/>	New Revenue	<input type="checkbox"/>		

Project Description: Photo (click image to insert):

Building on initial study undertaken in 2021, by the Massachusetts Safe Routes to Schools program, conceptual planning for potential improvements is ongoing among the Town Manager and key Town and Pentucket personnel incl. DPW, Public Safety, Water Dept., PRSD Facilities, and PRSD Administration. Presently working with traffic engineer (TEC, Inc.) to determine feasibility of conceptual plan. If concept plan found to be feasible, will propose funds for design/engineering and cost estimating.

Arrival/Dismissal Details

Dates: September 22, 2021
 Observations: 7:45 a.m. and 2:00 p.m.
 Weather: Partly sunny, 70-77 degrees Fahrenheit
 Grades: PK-5
 Enrollment: 298
 Building opened: 1974 Renovated: 1985

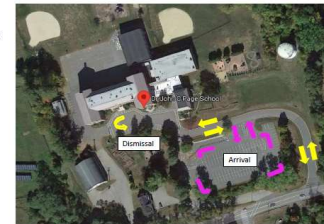

Project Financing:

Total Project Cost: \$300,000 Stabilization Funding: \$0

Amount & Type of Other Local Funding (ie. CPC, bond, op. budget): \$0 Comments: Portion of costs may be eligible for Ch. 90 funding

Amount and Type of Non-Local Funding Sources (ie. Grant): \$0 Comments:

Future Costs & Operating Expenses:

Estimated Annual Cost of Operation & Maintenance: \$0 Comments:

Estimated Net Effect on Operating Cost, Revenues, Staffing? \$0 Comments:

Project Planning:

Proposed Start Date of Project: unknown

How was estimated cost determined? Guesstimate

Is Funding Necessary for Further Plans/Estimating?

Can the Project be Phased? If yes, expenditure by year

	FY21	FY22	FY23	FY24	FY25	FY26	FY27	FY28	FY29	FY30+	TOTAL
PROPOSED	\$	\$	\$	\$	\$0	\$300,000	\$	\$	\$	\$	\$300,000
CIC RECC.	\$	\$	\$	\$	\$	\$	\$	\$	\$	\$	\$
APPROVED	\$	\$	\$	\$	\$	\$	\$	\$	\$	\$	\$

Town of West Newbury

2024 Spring Town Meeting (FY25)

42

ARTICLE REQUEST FORM

ARTICLE: *To fund Town-Wide Removal of Dead Ash Trees along Public Roadways*

AMOUNT REQUESTED: \$50,000

CONTACT PERSON: Butch Hills, DPW Highway Superintendent

PHONE NUMBER: 978-363-1100 x120

Why should the Town make this purchase? What needs will be met? Who will benefit?

Unhealthy and dead trees along public roadways may present various degrees of hazard and risk to the people and properties of West Newbury. The Department of Public Works (DPW) has the responsibility to address these hazards and to alleviate unacceptable risks. The Emerald Ash Borer infestation has caused many public roadway ash trees to become seriously diseased or dead and present the DPW with a situation in which approximately 373 ash trees need to be removed.

The Department of Public Works is seeking funds to remove some of these 373 Ash trees along public roadways that were deemed as candidates for removal in the Ash Tree Surveys performed by Bartlett Tree Experts in 2022 and 2023. These funds will not cover the removal of all 373 trees, which will take several years to fund to completion. In the initial 2022 Survey, 466 Ash trees were identified and tagged along public roadways. 177 of those trees were selected for the Emerald Ash Borer injection treatment in the early summer of 2023. A follow-up survey in fall 2023 revealed that 88 of those 177 trees were healthy enough to merit additional injection, whereas the other 89 trees were unhealthy enough to be candidates for removal. Thus, the total number of roadway ash trees that are now candidates for removal has reached 373.

For many years, the DPW has had an ongoing program for removal of High Hazard trees, and the DPW will continue to fund the removal of such trees within their regular operating budget, if approved. However, this ongoing program is not designed or sufficient for handling the current number of public roadway ash trees that should be removed. As a result, the DPW is seeking this additional funding to address need to alleviate the situation that now exists with respect to the 373 ash trees that have been identified as candidates for removal. While the \$50,000 of additional funding will not address all 373 trees, it will allow the DPW to address the trees along highly traveled public roads that are likely to present a higher degree of hazard. This additional funding will also inform the DPW on the amount of funding that may be required to address all the 373 ash trees that merit removal over the next several years.

What factors affect the timing of this purchase?

Some of these trees are on highly traveled roads, causing a greater potential safety risk to roadway traffic, pedestrians, utility service, and adjacent properties. As a result, the DPW is seeking an additional \$50,000 under this special warrant article so that some of the ash trees along highly traveled roads can be removed as soon as feasible, starting immediately after spring town meeting.

When should this Article be sunsetted - how long will the project take?

The project undertaken with these additional funds is anticipated to be completed by fall 2024. A sunset date of June 30, 2025 is recommended.

What ancillary costs do you anticipate? (Maintenance, Insurance, Training, etc.)

No additional costs are anticipated as the removal work will be contracted out.

Does this Article involve improvement, preservation or creation of tangible Town-owned assets and projects which 1) have useful life of at least five years; 2) cost over \$20,000 and or 3) for which the Town is authorized to borrow funds? If so, please confirm that this item is on the Capital Improvements Committee Schedule for future capital investments.

This article is a free cash request.

Please attach additional pages or other supporting documentation.

Town of West Newbury
2024 Spring Town Meeting (FY25)

43

ARTICLE REQUEST FORM

ARTICLE: *Remove and replace retaining wall in front of 1910 building (Town Offices)*

AMOUNT REQUESTED: \$12,000

CONTACT PERSON: Brian Richard, Facilities Manager

PHONE NUMBER: 978-914-2546

Why should the Town make this purchase? What needs will be met? Who will benefit?

The Department of Public Works is looking to remove and replace the existing retaining wall that is located in front of the 1910 Building. The wall is currently falling down and needs to be replaced. The existing wall will need to be removed, footing and drainage will need to be prepared for the new wall. The new wall will then be fabricated with the existing materials.

What factors affect the timing of this purchase?

The wall continues to deteriorate with each weather event. The sooner it's replaced, the more existing material we can use.

When should this Article be sunsetted - how long will the project take?

Recommended sunset date of June 30, 2026

What ancillary costs do you anticipate? (Maintenance, Insurance, Training, etc.)

No additional cost anticipated.

Does this Article involve improvement, preservation or creation of tangible Town-owned assets and projects which 1) have useful life of at least five years; 2) cost over \$20,000 and or 3) for which the Town is authorized to borrow funds? If so, please confirm that this item is on the Capital Improvements Committee Schedule for future capital investments.

This article is a free cash request.

Please attach additional pages or other supporting documentation.



ARTICLE REQUEST FORM

ARTICLE: To see if the Town will vote to transfer from available funds a sum to fund unbudgeted personnel costs

AMOUNT REQUESTED: TBD

CONTACT PERSON: Angus Jennings, Town Manager

PHONE NUMBER: 978-363-1100 x115

Why should the Town make this purchase? What needs will be met? Who will benefit?

The FY24 operating budget expense line for Police Overtime is overspent, and the Dispatch Overtime budget is on track to be overspent. The combined amount by which these expense lines are expected to be overspent by the end of FY24 is projected to exceed the amount that could be covered by a Reserve Fund transfer.

Therefore, an Article to fund these costs is proposed for the Spring 2024 Town Meeting, to ensure that these expense lines do not end FY24 in deficit.

Also, at the time the FY25 operating budget was proposed, FY25 union contracts for Police and Dispatch had not yet been settled. The proposed budget carries amounts estimated to be sufficient to cover FY25 costs. However, this article is put forth in good faith, in case circumstances arise where the Police or Dispatch Salary & Wages line items are under budgeted based on yet-to-be-agreed contract terms. Further, with Select Board approval, these funds may potentially be used to cover other unbudgeted costs as may result.

What factors affect the timing of this purchase?

These funds would be used in part to offset or absorb FY24 personnel costs above budgeted levels.

When should this Article be sunsetted - how long will the project take?

FY25

What ancillary costs do you anticipate? (Maintenance, Insurance, Training, etc.)

N/A

Does this Article involve improvement, preservation or creation of tangible Town-owned assets and projects which 1) have useful life of at least five years; 2) cost over \$20,000 and or 3) for which the Town is authorized to borrow funds? If so, please confirm that this item is on the Capital Improvements Committee Schedule for future capital investments.

No

Please attach additional pages or other supporting documentation.

ARTICLE REQUEST FORM

ARTICLE: DPW request additional funds for the Snow and Ice Removal Program

AMOUNT REQUESTED: Placeholder number to be reviewed/revised as Board gets closer to posting and signing Warrant

CONTACT PERSON: Butch Hills, Highway Director

PHONE NUMBER: 978-363-1100 x120

Why should the Town make this purchase? What needs will be met? Who will benefit?

An estimated \$XX,XXX has been expended YTD leaving a remaining balance of approximately \$XXX,XXX in the available budget line. We do expect some larger scale events to occur similar to previous years. Prior complete year Snow and Ice total spending (including overages approved at prior Town Meetings) show expenditures of \$54,198.43 (FY23) \$227,245 (FY22), \$224,021 (FY21), and \$211,087 (FY20). As a result, I request additional funds to allow DPW to perform this important operation to the degree of satisfaction expected by the residents of our Town.

What factors affect the timing of this purchase?

This is considered operations and the funds are needed to complete our snow and ice work for this season. This request is proposed for inclusion on the Special Town Meeting warrant in order to make funds available during the current fiscal year 2024.

When should this Article be sunsetted - how long will the project take?

Recommended sunset date of June 30, 2024

What ancillary costs do you anticipate? (Maintenance, Insurance, Training, etc.)

None

Does this Article involve improvement, preservation or creation of tangible Town-owned assets and projects which 1) have useful life of at least five years; 2) cost over \$20,000 and or 3) for which the Town is authorized to borrow funds? If so, please confirm that this item is on the Capital Improvements Committee Schedule for future capital investments.

N/A

Please attach additional pages or other supporting documentation.

ARTICLE REQUEST FORM

ARTICLE: Prior fiscal year unpaid bills that are deemed to be legal obligations of the Town.

AMOUNT REQUESTED: TBD

CONTACT PERSON: Jennifer Walsh, Town Accountant

PHONE NUMBER: 978-363-1100 ext 112

Why should the Town make this purchase? What needs will be met? Who will benefit?

To see if the Town will vote to transfer from available funds the sum above to pay the following unpaid bills incurred from previous fiscal year(s), or take any other action in relation thereto. In accordance with MGL Chapter 44, Section 64, unpaid bills from a prior fiscal year can only be paid from current year appropriations with the specific approval of Town Meeting. For Special Town Meetings a 9/10ths vote is required.

DEPARTMENT	VENDOR	AMOUNT
Police	Uncollectable Details 6-10-2023	\$720.00
DPW	National Grid - Pole 90	TBD

What factors affect the timing of this purchase?

N/A

When should this Article be sunsetted - how long will the project take?

N/A

What ancillary costs do you anticipate? (Maintenance, Insurance, Training, etc.)

N/A

Does this Article involve improvement, preservation or creation of tangible Town-owned assets and projects which 1) have useful life of at least five years; 2) cost over \$20,000 and or 3) for which the Town is authorized to borrow funds? If so, please confirm that this item is on the Capital Improvements Committee Schedule for future capital investments.

N/A

Please attach additional pages or other supporting documentation.



American Legion Riders

Wilbur M. Comeau

Massachusetts Chapter, Post 4, Haverhill MA

To: West Newbury Police Department,

This letter is being sent in regard to the invoice we received dated 6/10/23. We reached out to you informing you of a charity ride we were organizing that would be traveling through your town, as a courtesy. We did not requested detail officers, we simply sent a letter to keep you informed. We have completed many charity rides, and have never been charged by any town or city.

The American Legion Riders is a non profit group of volunteers, who are committed to supporting our veterans, our military troops, our community, special charities and also offer scholarships. This particular ride was a charity ride for the Disabled and Limbless Veterans, which is a charity who provides meals, clothing and shelter to Veteran's and their families who require services and support.

We are asking you to please credit the invoice, as this takes away any fundraising that would be given to said charities.

Thank you in advance,

Shirley Breen

ALR Secretay

WEST NEWBURY POLICE DEPARTMENT
DETAIL ACCOUNT #902580

<u>INV DATE</u>	<u>Inv #</u>	<u>DATE WKD</u>	<u>OFFICERS NAME</u>	<u>BILL TO</u>	<u>TOTAL WAGE</u>	<u>CRUISER</u>	<u>ADMIN CHG</u>	<u>TOTAL DUE</u>
6/12/2023	23-50B	6/10/2023	Eng, Jessica	American Legion Riders	\$360.00	\$0.00	\$36.00	\$396.00
6/12/2023	23-50B	6/10/2023	Terrero, Manny	American Legion Riders	\$360.00	\$10.00	\$36.00	\$406.00
				<u>TOTAL</u>	\$720.00	\$10.00	\$72.00	\$802.00

Michael D...

(d)

CHIEF OF POLICE

BOARD OF SELECTMEN

WEST NEWBURY POLICE DETAIL ACCOUNT

INV.#: 23-50B

OFFICERS NAME: Eng, Jessica

INVOICE DATE: 6/12/2023 TIME: 10:30am-11:10am

DATE WORKED: 6/10/2023

JOB LOCATION: Bridge St @ Main

<u>HOURS WORKED</u>	<u>PAY</u>
REGULAR:	REG: 0.00
OVERTIME: 4	OT: 360.00
CRUISER:	S/M: 0.00
SCH/MUN OT:	S/M OT: 0.00

TOTAL WAGE: 360.00

CRUISER.: 0

ADMN CHARGE: 36.00

TOTAL BILLED: 396.00

BILL TO: American Legion Riders

ADDRESS:

CITY/TOWN:

WEST NEWBURY POLICE DETAIL ACCOUNT

INV.#: 23-50B

OFFICERS NAME: Terrero,Manny
INVOICE DATE: 6/12/2023 TIME: 10:20am-11am
DATE WORKED: 6/10/2023

JOB LOCATION: Turkey Hill @ South

HOURS WORKED

PAY

REGULAR:		REG:	0.00
OVERTIME:	4	OT:	360.00
CRUISER:	1	S/M:	10.00
SCH/MUN OT:		S/M OT:	0.00

TOTAL WAGE: 360.00
CRUISER:: 10
ADMN CHARGE: 36.00
TOTAL BILLED: 406.00

BILL TO: American Legion Riders
ADDRESS:
CITY/TOWN:

Sep 29, 2022 to Oct 31, 2022
corrected bill

ACCOUNT NUMBER

PLEASE PAY BY

AMOUNT DUE

90661-02000

Mar 5, 2024

\$ 490.00

www.nationalgridus.com

CUSTOMER SERVICE
 1-800-322-3223
 CREDIT DEPARTMENT
 1-888-211-1313

POWER OUTAGE OR DOWNED LINE
 1-800-465-1212

CORRESPONDENCE ADDRESS
 PO Box 960
 Northborough, MA 01532-0960

ELECTRIC PAYMENT ADDRESS
 PO BOX 371396
 PITTSBURGH, PA 15250-7396

DATE BILL ISSUED
 Jan 10, 2024

▶ CORRECTED BILL ◀

ACCOUNT BALANCE

Previous Balance	-5.80
Payment Received <i>No payments have been received during this billing period</i>	- 0.00
Balance Forward	-5.80
Current Charges	+ 495.80
Amount Due ▶	\$ 490.00

To avoid late payment charges of 1.02%, \$ 490.00 must be received by Mar 5 2024.

This bill reflects credit for previous billings that have been corrected. Your previous balance includes charges from prior billings.

DETAIL OF CURRENT CHARGES**Delivery Services**

Type of Service	Current Reading	Previous Reading	Difference	Meter Multiplier	Total Usage
Energy	60261 <i>Actual</i>	58063 <i>Estimate</i>	2198	1	2198 kWh
Total Energy					2198 kWh

Demand-kW 16.2 kW
Demand-kVA 18.0 kVA

Billed Demand 0.0 kW

METER NUMBER 25197404 NEXT SCHEDULED READ DATE ON OR ABOUT Feb 1
 SERVICE PERIOD Sep 29 - Oct 31 NUMBER OF DAYS IN PERIOD 32
 RATE General Service - Small C/I G-1 VOLTAGE DELIVERY LEVEL 0 - 2.2 kv

Enrollment Information

To enroll with a supplier or change to another supplier, you will need the following information about your account:

Loadzone NEMA/BOST
 Acct No: 90661-02000 Cycle: 3, TOWN

Electric Usage History

Month	kWh	Month	kWh
Nov 21	1674	Jun 22	2060
Dec 21	2252	Jul 22	2061
Jan 22	2898	Aug 22	2129
Feb 22	3155	Sep 22	2060
Mar 22	3167	Oct 22	1991
Apr 22	3130	Nov 22	2198
May 22	3040		

Acct: 01-424-5410

Amount: 490.00

Date: 01-17-2024

Authorized Signature

KEEP THIS PORTION FOR YOUR RECORDS.

RETURN THIS PORTION WITH YOUR PAYMENT.

ACCOUNT NUMBER

PLEASE PAY BY

AMOUNT DUE

90661-02000

Mar 5, 2024

\$ 490.00

▶ CORRECTED BILL ◀

PO Box 960
 Northborough MA 01532

ENTER AMOUNT ENCLOSED

\$

Write account number on check and make payable to National Grid
 Please pay Gas & Electric bills separately

1045439 01 AB 0.537 **AUTO T8 0 3007 01985-149981 -C03-P45484-1123



TOWN OF WEST NEWBURY

381 MAIN ST
 WEST NEWBURY MA 01985-1499

049275

NATIONAL GRID
 PO BOX 371396
 PITTSBURGH PA 15250-7396



000049580 90661020009000049000065

SERVICE FOR
TOWN OF WEST NEWBURY
381 MAIN ST POLE 90
WEST NEWBURY MA 01985

BILLING PERIOD
Dec 1, 2022 to Dec 30, 2022

ACCOUNT NUMBER 90661-02000
PLEASE PAY BY Mar 7, 2024

AMOUNT DUE
\$ 2,328.83

www.nationalgridus.com

CUSTOMER SERVICE
1-800-322-3223
CREDIT DEPARTMENT
1-888-211-1313

POWER OUTAGE OR DOWNED LINE
1-800-465-1212

CORRESPONDENCE ADDRESS
PO Box 960
Northborough, MA 01532-0960

ELECTRIC PAYMENT ADDRESS
PO BOX 371396
PITTSBURGH, PA 15250-7396

DATE BILL ISSUED
Jan 12, 2024

► **CORRECTED BILL** ◀

ACCOUNT BALANCE

Previous Balance	1,454.34
Payment Received <i>No payments have been received during this billing period</i>	- 0.00
Balance Forward	1,454.34
Current Charges	+ 874.49
Amount Due ►	\$ 2,328.83

To avoid late payment charges of 1.02%, \$ 2,328.83 must be received by Mar 7 2024.

This bill reflects credit for previous billings that have been corrected. Your previous balance includes charges from prior billings.

DETAIL OF CURRENT CHARGES

Delivery Services

Type of Service	Current Reading	Previous Reading	Difference	Meter Multiplier	Total Usage
Energy	64450 <i>Estimate</i>	62459 <i>Estimate</i>	1991	1	1991 kWh
Total Energy					1991 kWh

Demand-kW 16.2 kW
Demand-kVA 18.0 kVA

Billed Demand 0.0 kW

METER NUMBER 25197404 NEXT SCHEDULED READ DATE ON OR ABOUT Feb 1
SERVICE PERIOD Dec 1 - Dec 30 NUMBER OF DAYS IN PERIOD 29
RATE General Service - Small C/I G-1 VOLTAGE DELIVERY LEVEL 0 - 2.2 kv

Enrollment Information

To enroll with a supplier or change to another supplier, you will need the following information about your account:
Loadzone NEMA/BOST
Acct No: 90661-02000 Cycle: 3, TOWN

Electric Usage History

Month	kWh	Month	kWh
Jan 22	2898	Aug 22	2129
Feb 22	3155	Sep 22	2060
Mar 22	3167	Oct 22	1991
Apr 22	3130	Nov 22	2198
May 22	3040	Dec 22	2198
Jun 22	2060	Jan 23	1991
Jul 22	2061		

Acct: 01-424-5410

Amount: 2328.83

Date: 01-22-2024

Authorized Signature

KEEP THIS PORTION FOR YOUR RECORDS.

RETURN THIS PORTION WITH YOUR PAYMENT.

ACCOUNT NUMBER	PLEASE PAY BY	AMOUNT DUE
90661-02000	Mar 7, 2024	\$ 2,328.83

► **CORRECTED BILL** ◀

ENTER AMOUNT ENCLOSED

\$

Write account number on check and make payable to National Grid
Please pay Gas & Electric bills separately

PO Box 960
Northborough MA 01532

1046424 01 AB 0.537 **AUTO T7 0 3009 01985-14981 -C03-P46470-1123



TOWN OF WEST NEWBURY
381 MAIN ST
WEST NEWBURY MA 01985-1499

050465

NATIONAL GRID
PO BOX 371396
PITTSBURGH PA 15250-7396



ARTICLE REQUEST FORM

ARTICLE: Zoning Amendment - MBTA Communities Multi-Family Overlay District (MCMOD)

AMOUNT REQUESTED: 0

CONTACT PERSON: Sue Brown, Town Planner

PHONE NUMBER: 978-363-1100 x 125

Why should the Town make this purchase? What needs will be met? Who will benefit?

The Town is obligated under Ch 40A Section 3A to adopt a Multi-Family Overlay District that allows multi-family housing by right. By adopting the MCMOD, the Town will be in compliance with the law. Communities that fail to comply with the Law will be ineligible for some State funding and may be subject to civil enforcement action. Communities that fail to comply with the Law's requirements also risk liability under federal and state fair housing laws. The Law requires that MBTA Communities "shall have" a compliant zoning district and does not provide any mechanism by which a town or city may opt out of this requirement. Further, new housing developed under the MCMOD bylaw would help diversify the Town's housing stock as is recommended in various Town Plans including past Comprehensive Plans and past and current Housing Production Plan.

What factors affect the timing of this purchase?

N/A

When should this Article be sunsetted - how long will the project take?

N/A

What ancillary costs do you anticipate? (Maintenance, Insurance, Training, etc.)

N/A

Does this Article involve improvement, preservation or creation of tangible Town-owned assets and projects which 1) have useful life of at least five years; 2) cost over \$20,000 and or 3) for which the Town is authorized to borrow funds? If so, please confirm that this item is on the Capital Improvements Committee Schedule for future capital investments.

No

Please attach additional pages or other supporting documentation.

ARTICLE REQUEST FORM

ARTICLE: Wetlands Protection Bylaw

AMOUNT REQUESTED: \$0.00

CONTACT PERSON: Michelle Greene, Conservation Agent; Molly Hawkins, Conservation Commission Chair

PHONE NUMBER: Michelle: 978-363-1100 x126, conservation@wnewbury.org
Molly: mhawkins513@hotmail.com

Why should the Town make this purchase or adopt this article? What needs will be met? Who will benefit?

Wetlands and their bordering lands, called buffer zones, are important resource areas in our community that provide essential functions, called interests or resource area values, that include the protection of public and private water supplies, storm damage prevention, flood control, and wildlife habitat.

The state Wetlands Protection Act (M.G.L. Ch. 131 sec. 40, the “Act”) protects eight public interests provided by wetlands and is administrated locally by the West Newbury Conservation Commission (WNCC). Since the Act’s enactment in 1972, there is now better understanding of just how valuable and irreplaceable wetlands are. Science has shown that activities immediately adjacent to wetlands can permanently alter them and reduce or eliminate their resource area values like the ability to protect a community’s drinking water or storm resilience. In a changing climate that is seeing more frequent and more significant precipitation and flooding, it is vital that wetlands are protected comprehensively so that they can provide the maximum values possible to the community. To ensure stronger protections to irreplaceable wetland resource areas and to ultimately better protect residents, 220 of the state’s 352 municipalities, including 29 of Essex County’s 34 municipalities, have already enacted local wetlands protection bylaws.

Enacting a wetlands protection bylaw under the Home Rule authority of the Town of West Newbury that is more protective than the Act will increase community control over activities in wetlands and their buffer zones, limit community costs from the degradation of wetlands, guide development to be more sustainable, and provide better protection of our community’s wetlands and the values they provide for us by:

- recognizing and protecting resource area values deemed important by the community beyond those identified in the Act including, but not limited to, recreation, agriculture, rare species habitat, and aquaculture;
- recognizing and protecting additional wetland resource areas beyond those identified in the Act including, but not limited to, an expanded vernal pool habitat area essential to the survival of vernal pool dependent species and recognizing the 100-foot buffer zone of wetlands as a resource area allowing the WNCC to create equitable and transparent performance standards for activities proposed in the buffer zone; and
- enabling the WNCC to issue fines when wetlands violations occur; an enforcement mechanism not provided to conservation commissions under the Act.

Enacting a local wetlands protection bylaw increases the Town’s competitiveness for certain grant funding opportunities. It also satisfies the Town’s long-standing objectives of increased

wetland and water protections that have been identified in various Town plans and reports including:

- [1999 Comprehensive Plan](#) which includes a goal of protecting aquifers and groundwater recharge areas;
- [2015 Hazard Mitigation Plan](#) which indicates that enactment of a local wetlands protection bylaw would be a “very effective” tool to reduce hazards in Town such as flooding, erosion, and impaired drinking water;
- [2018 Open Space and Recreation Plan](#) which included an action item to enact a local wetlands protection bylaw by 2019 to protect against flooding due to climate change, protect surface water quality, and preserve wetlands; and
- [2020 Municipal Vulnerability Preparedness Workshop Summary of Findings](#) which specifically called for enactment of a wetlands protection bylaw to improve local land use controls.

What factors affect the timing of this purchase or this request?

Wetlands and buffer zones continue to be lost and degraded through development and disturbance. As flat, dry parcels of land become increasingly scarce regionally, development pressure increases on parcels in close proximity of wetlands. By adopting a wetlands protection bylaw and comprehensively protecting wetland resource areas and values, the Town will be:

- protecting current and future inhabitants from the impacts of degraded wetlands including the loss of flood control, loss of storm damage protection, and impaired drinking water;
- saving future homeowners from costs associated with flooded and damaged properties; and
- reducing tax dollars spent addressing issues that arise from degraded wetlands and the loss of infrastructure constructed in or within close proximity to wetlands.

Enactment of a local wetlands protection bylaw also aligns with recent state guidance and goals to improve resiliency to the impacts of a changing climate in Massachusetts. The [2022 Massachusetts Climate Change Assessment](#) highlights the need for the North shore to plan for impacts to infrastructure loss due to flooding and water quality impairment due to changes in precipitation. The [2023 Executive Order No. 618: Biodiversity Conservation in Massachusetts](#) calls attention to the importance of the state’s various habitat areas including “critical wetlands”, recognizes that these areas provide habitat to a “wide variety of plants, animals, and other organisms and which offer vital ecological, economic, and public health benefits to its people”, and recommends goals to halt and reverse species loss in Massachusetts.

What ancillary costs do you anticipate? (Maintenance, Insurance, Training, etc.)

The WNCC does not anticipate any increased costs from the enactment of a local wetlands protection bylaw. The WNCC will continue to budget for commission members and its agent to participate in training and continuing education opportunities to ensure the sound application of the Act and a local wetlands protection bylaw.

Please attach any supporting materials.

Please see attached:

- Draft Wetlands Protection Bylaw

**Town of West Newbury
Conservation Commission**

DRAFT 1/24/2024

WETLANDS PROTECTION BYLAW

Sections:

- | | |
|---|--|
| 1. Purpose | 8. Decisions and Conditions |
| 2. Jurisdiction | 9. Security |
| 3. Exemptions & Exceptions | 10. Appeals |
| 4. Definitions | 11. Enforcement |
| 5. Burden of Proof | 12. Regulations |
| 6. Applications, Fees, & Outside Consultants | 13. Relation to Wetlands Protection Act |
| 7. Notice, Public Hearings, and Public Meetings | 14. Severability |
| | 15. Effective Date |

1. Purpose

The purpose of this bylaw is to protect the wetlands, water resources, flood-prone areas, and adjoining upland areas in the Town of West Newbury by regulating activities deemed by the Conservation Commission (“Commission”) likely to have a significant or cumulative adverse effect on resource area values deemed important to the community (collectively, the “resource area values protected by this bylaw”), including but not limited to the following:

- 1.1** Public or private water supply;
- 1.2** Groundwater supply;
- 1.3** Flood control;
- 1.4** Erosion and sedimentation control;
- 1.5** Storm damage prevention including coastal storm flowage;
- 1.6** Water quality;
- 1.7** Prevention and control of water pollution;
- 1.8** Agriculture;
- 1.9** Fisheries, including aquaculture;
- 1.10** Wildlife habitat;
- 1.11** Rare species habitat, including rare plant and animal species; and
- 1.12** Recreation.

This bylaw is subject, however, to the rights and benefits accorded to agricultural uses and structures of all kinds under the laws of the Commonwealth and other relevant bylaws of the Town of West Newbury.

This bylaw is intended to utilize the Home Rule authority of West Newbury to protect the resource areas under the Wetlands Protection Act (G.L. c.131, §40; the Act) to a greater degree, to protect additional resource areas beyond those protected in the Act recognized by the Town as significant, to protect all resource areas for their additional values beyond those identified in the Act, and to impose, in local regulations and permits, Orders of Conditions, and Determinations of Applicability additional standards and procedures in addition to those of the Act and regulations thereunder (310 CMR 10.00).

2. Jurisdiction

Except as permitted by the Commission or as provided in Section 3 of this bylaw, no person shall remove, fill, dredge, build upon, degrade, discharge into, or otherwise alter the following resource areas (collectively the “resource areas protected by this bylaw”):

- 2.1 Any freshwater or coastal wetlands, isolated wetlands, marshes, wet meadows, bogs, swamps and adjoining land extending out to a distance of 100 feet, known as the Buffer Zone;
- 2.2 Any freshwater or coastal bank or beach bordering on any lake, pond, reservoir, river, stream, brook, or creek and adjoining land extending out to a distance of 100 feet, known as the Buffer Zone;
- 2.3 Any perennial rivers, streams, brooks and creeks and lands adjoining these resource areas out to a distance of 200 feet, known as the Riverfront Area;
- 2.4 Any land under the aforementioned waterbodies and waterways;
- 2.5 Any vernal pools and adjoining land extending out 100 feet, known as the Vernal Pool Habitat;
- 2.6 Any lands subject to flooding;
- 2.7 Any lands subject to tidal action; and
- 2.8 Any lands subject to coastal storm flowage.

Said resource areas shall be protected whether or not they border surface waters.

3. Exemptions and Exceptions

The following exemptions shall apply:

- 3.1 Activities in the Buffer Zone and Riverfront Area Pursuant to 310 CMR 10.02 (2)(a) and 310 CMR 10.02 (2)(b)1. and 2., and as may be Amended by the Massachusetts Department of Environmental Protection (“MassDEP”)

The exemptions provided in the Wetlands Protection Act (G.L. c. 131 §40, the Act) and regulations (310 CMR 10.00) shall apply under this bylaw provided that advance notice, oral or written, of at least 72 hours has been given to the Commission or its agent before the commencement of work and provided that the work also conforms to any performance standards and design specifications as written in the Act and regulations and to any performance standards and design specifications in regulations adopted by the Commission.

- 3.2 Emergency Projects

Projects necessary for the protection of the health and safety of the public, provided that the work is to be performed by or has been ordered to be performed by an agency of the Commonwealth or a political subdivision thereof and provided that advance notice, oral or written, has been given to the Commission or its agent before the commencement of work or within 24 hours after the commencement and provided that the Commission or its agent certifies the work as an emergency project and provided that the work is performed only for the time and place certified by the Commission or its agent for the limited purposes necessary to abate the emergency. Upon failure to meet these and other requirements of the Commission, the Commission may, after notice and a public hearing, revoke or modify an emergency project approval and order restoration and mitigation measures.

- 3.3 Agriculture

Work performed for normal maintenance or improvement of land in agricultural and/or aquacultural use as defined by the Wetlands Protection Act regulations at 310 CMR 10.04.

- 3.4 Routine Mowing and Maintenance of Lawns, Gardens, and Landscaped Areas

The routine mowing and maintenance of lawns, gardens, and landscaped areas shall be exempt from this bylaw provided that these areas were lawfully in existence on the effective date of this bylaw or were created after such date in accordance to any performance standards and design specifications in regulations adopted by the Commission.

4. Definitions

The following definitions shall apply in the interpretation and implementation of this bylaw.

The term "agriculture" shall refer to the definition provided by G.L. c. 128, §1A.

The term "alter" shall include, without limitation, the following activities when undertaken to, upon, within, or affecting resource areas protected by this bylaw:

- a. Removal, excavation, or dredging of soil, sand, gravel, or aggregate materials of any kind;
- b. Changing of preexisting drainage characteristics, flushing characteristics, salinity distribution, sedimentation patterns, flow patterns, or flood retention characteristics;
- c. Drainage, or other disturbance of water level or water table;
- d. Dumping, discharging, or filling with any material which may degrade water quality;
- e. Placing of fill, or removal of material, which would alter elevation;
- f. Driving of piles, erection, or expansion of buildings or structures of any kind;
- g. Placing of obstructions or objects in water;
- h. Destruction of plant life including but not limited to cutting or trimming of trees, shrubs, and other vegetation;
- i. Changing temperature, biochemical oxygen demand, or other physical, biological, or chemical characteristics of any waters;
- j. Any activities, changes, or work that may cause or tend to contribute to pollution of any body of water or groundwater; and/or
- k. Incremental activities which have, or may have, a cumulative adverse effect on the resource areas protected by this bylaw.

The term "bank" shall include the land area which normally abuts and confines a water body; the lower boundary being the mean annual low flow level, and the upper boundary being the first break in the slope observed in the field or the mean annual high water line, whichever is higher.

The term "cumulative adverse effect" shall mean the adverse effects of activities regulated under this bylaw which may be individually insignificant to the interests and values under this bylaw, but when considered in relation to other past or present activities in a given area may be significant to said interests and values in the aggregate.

The term "interests" shall mean the resource area values and resource areas protected by this bylaw.

The term "isolated wetlands" means freshwater wetlands not bordering on a water body and at least 5,000 square feet in surface area.

The term "land subject to coastal storm flowage" shall mean land subject to any inundation by any tidally influenced river, stream, creek, and/or brook caused by coastal storms up to and including that caused by the 100-year storm, surge of record or storm of record, whichever is greater.

The term "land subject to tidal action" shall mean land subject to the periodic rise and fall of any tidally influenced river, stream, creek, and/or brook, or of a coastal water body, including spring tides.

The term "permit" shall mean a document issue by the Commission solely under this bylaw or regulations promulgated hereunder.

The term "pond" shall follow the definition of 310 CMR 10.04, and as may be amended, except a size threshold of 5,000 square feet shall apply.

The term "rare species" shall include, without limitation, all vertebrate and invertebrate animals and all plant species listed as endangered, threatened, or of special concern by the Massachusetts Division of Fisheries and Wildlife, the United States Fish and Wildlife Service, and/or the National Oceanic and Atmospheric

Administration regardless of whether the habitat in which they occur has been previously identified and/or mapped by the Massachusetts Division of Fisheries and Wildlife Natural Heritage and Endangered Species Program.

The term "vernal pool" shall include, in addition to scientific definitions found in the regulations under the Wetlands Protection Act, any confined basin or depression not occurring in existing lawns, gardens, landscaped areas or driveways which, at least in most years, holds water for a minimum of two continuous months during the spring and or summer, is free of adult predatory fish populations, and provides essential breeding and rearing habitat functions for amphibian, reptile or other vernal pool community species which have been found in the basin or depression. The boundary of the vernal pool is the mean annual high-water line defining the depression. A vernal pool may be subject to jurisdiction hereunder regardless of whether it has been certified by the Massachusetts Division of Fisheries and Wildlife's Natural Heritage and Endangered Species Program.

The term "written notice" shall include notice by electronic mail.

Except as otherwise provided in this bylaw or in associated regulations of the Commission, the definitions of terms and the procedures in this bylaw shall be as set forth in the Wetlands Protection Act (G.L. c. 131, §40) and regulations (310 CMR 10.00).

5. Burden of Proof

The applicant for a permit, Notice of Intent, or Request for Determination of Applicability shall have the burden of proving by a preponderance of the credible evidence that the work proposed in the application will not have significant or cumulative adverse effects on the interests protected by this bylaw. Failure to provide adequate evidence to the Commission supporting this burden shall be sufficient cause for the Commission to deny a permit or Order of Conditions or grant a permit, Order of Conditions, or Determination of Applicability with conditions, or, at the Commission's discretion and with the applicant's permission, to continue a public hearing or meeting to another date to enable the applicant or others to present additional evidence upon such terms and conditions the Commission deems reasonable.

6. Applications, Fees, & Outside Consultants

6.1 Application

A written application shall be filed with the Commission to perform activities that may impact resource areas protected by this bylaw. No activities under the jurisdiction of this bylaw shall commence without receiving and complying with a permit, Order of Conditions, or Determination of Applicability issued pursuant to this bylaw.

The application shall include such information and plans deemed necessary by the Commission to describe proposed activities and their effects on the resource areas protected by this bylaw. The Commission may accept as the application and plans under this bylaw any application and plans filed under the Wetlands Protection Act (G.L. c. 131 §40) and regulations (310 CMR 10.00) where they are sufficient to meet the requirements of the bylaw and any regulations promulgated thereunder. The Commission may require additional materials or information in addition to the plans and specifications required to be filed by an applicant under the Wetlands Protection Act (G.L. c. 131 §40) and regulations (310 CMR 10.00), in order to fulfill the requirements of this bylaw.

6.2 Request for Determination of Applicability (RDA)

Any person desiring to know whether or not a proposed activity or an area is subject to this bylaw may request, in writing, a Determination of Applicability from the Commission. The Commission shall accept a Request for Determination of Applicability (RDA) under the Wetlands Protection Act (G.L. c. 131 §40) as a request under this bylaw. Such RDA shall contain information and plans specified by the regulations

of the Commission. Any person desiring only to confirm delineations of resource area(s) on site shall file an Abbreviated Notice of Resource Area Delineation (ANRAD).

6.3 Abbreviated Notice of Resource Area Delineation (ANRAD)

Any person desiring to confirm, for purposes of this bylaw, the limits of resource areas on a site may file an Abbreviated Notice of Resource Area Delineation (ANRAD). This application shall include such information and plans as are set forth in the regulations of the Commission to describe and define the wetland resource areas. The Commission shall accept an ANRAD under the Wetlands Protection Act (G.L. c. 131 §40) and regulations (310 CMR 10.00) as an ANRAD under this bylaw.

6.4 Fees

At the time of an application, the applicant shall pay a filing fee specified in the regulations of the Commission. The fee is in addition to that required by the Wetlands Protection Act (G.L. c. 131 §40) and regulations (310 CMR 10.00).

6.5 Fee Waiver

The Commission may waive fees specified in the regulations of the Commission for applications filed by a government agency, including a municipal department, board, or committee. The Commission may also waive fees specified in the regulations of the Commission for applications filed for projects the Commission finds have a net benefit to wetland resources and a primary purpose of restoring wetland ecological functions.

6.6 Consultants

The Commission may, at the expense of the applicant and in accordance with the provisions of G.L. c. 44 §53G and regulations promulgated by the Commission, impose reasonable fees upon applicants to secure outside consultants including engineers, wetlands scientists, wildlife biologists, or other experts to aid in the review of proposed projects presenting technical issues requiring additional expertise to assist the Commission in protecting resource areas. Such funds shall be deposited with the town treasurer, who shall create an account specifically for this purpose. Additional consultant fees may be requested where the requisite review is more expensive than initially calculated or new information requires additional consultant services. This is intended to apply only to assist in reviewing projects deemed by the Commission to be large or complex.

7. Notice, Public Hearings, and Public Meetings

7.1 Abutter Notification

Any person filing a Notice of Intent or Abbreviated Notice of Resource Area Delineation, or for an amendment to an Order of Conditions shall follow the abutter notification requirements set forth in the Wetlands Protection Act (M.G.L. c. 131 §40) and regulations, 310 CMR 10.05(4), and as may be amended by the MassDEP.

7.2 Public Notice

The Commission shall provide written notice given at the expense of the applicant at least five business days prior to the public hearing or public meeting by publication in a newspaper of general circulation in West Newbury or in any other manner approved by the MassDEP. Where applicable, notice given for public meetings and public hearings under this bylaw may be combined with notice given for public meetings and public hearings under the Wetlands Protection Act (G.L. c. 131, §40) and regulations (310 CMR 10.00).

7.3 Public Hearings & Public Meetings

The Commission shall commence a public hearing on any permit application, Notice of Intent, Abbreviated Notice of Resource Area Delineation, or request to amend a final Order of Conditions, or a

public meeting on any Request for Determination of Applicability, within 21 days from receipt of a complete application, unless an extension is authorized in writing by the applicant.

The Commission shall have authority to request that an applicant agree to continue the public hearing or public meeting to a specific date announced at the hearing or meeting, for reasons stated at the hearing or meeting, which may include the need for additional information or plans required of the applicant or others as deemed necessary by the Commission. In the event that the applicant objects to a continuance or postponement, the hearing or meeting shall be closed and the Commission shall take action on such information as is available.

The Commission may combine its public hearing or public meeting under this bylaw with the public hearing or public meeting conducted under the Wetlands Protection Act (M.G.L. c. 131 §40) and Regulations (310 CMR 10.00).

8. Decisions and Conditions

8.1 Decision

The Commission shall issue its decision as a permit, Order of Conditions, denial, Order of Resource Area Delineation, or Determination of Applicability within 21 calendar days of the close of the public hearing or public meeting, unless the applicant authorizes an extension in writing. The Commission shall take into account the extent to which the applicant has avoided, minimized and mitigated any adverse effect to the interests of this bylaw. Each case will be considered on its own merits. Due consideration shall be given to any demonstrated hardship on the applicant by reason of denial, as presented at the public hearing or public meeting. The Commission may, in an appropriate case, combine the permit, Order of Conditions, Order of Resource Area Delineation, or Determination of Applicability issued under this bylaw with the Order of Conditions, Order of Resource Area Delineation, or Determination of Applicability issued under the Wetlands Protection Act (G.L. c. 131 §40) and regulations (310 CMR 10.00).

8.2 Waivers

Upon written request, the Commission may waive specifically identified and requested procedures, design specifications, performance standards, or other requirements set forth in this bylaw or regulations, provided that:

- a. The Commission finds in writing after said public hearing that there are no reasonable conditions or alternatives that would allow the proposed activity to proceed in compliance with said bylaw or regulations; and
- b. That avoidance, minimization and mitigation have been employed to the maximum extent feasible; and
- c. The project, when considered in its entirety, would result in a net benefit of resource areas values; and
- d. The waiver is necessary to accommodate an overriding public interest or to avoid a decision that so restricts the use of the property as to constitute an unconstitutional taking without compensation.

8.3 Approvals

The Commission is authorized to approve a permit or Order of Conditions when proposed work meets all applicable design specifications, performance standards and other requirements under this bylaw and in regulations of the Commission and where the work will not result in significant or cumulative adverse effects upon the interests protected by this bylaw, as determined by the Commission. Any permit or Order of Conditions issued under this bylaw may differ from any such permit or Order of Conditions issued by the Commission under the provisions of the Wetlands Protection Act (G.L. c. 131 §40) and regulations (310 CMR 10.00) (the "Act"), where the bylaw and regulations of the Commission are more protective of any resource area(s) than the Act.

8.4 Conditions

The Commission is authorized to impose conditions on any approved permit, Order of Conditions, or Determination of Applicability that the Commission deems necessary to protect the interests of this bylaw or to ensure that a project or activity proceeds in accordance with any design specifications, performance standards and other requirements in regulations of the Commission. If an approved permit Order of Conditions, or Determination of Applicability contains conditions, all activities shall be conducted in accordance with those conditions.

A permit or Order of Conditions may include conditions with requirements which shall be enforceable for a stated number of years, indefinitely, or until permanent protection is in place, and shall apply to all present and future owners of the land. These conditions may remain in full force and effect after issuance of a Certificate of Compliance if so noted on the Certificate of Compliance.

8.5 Entry

The Commission, its agents, officers, and employees shall have authority to request authorization to enter upon privately owned land to perform their duties under this bylaw subject to the constitutions and laws of the United States and the Commonwealth. They may make or cause to be made such examinations, surveys, or sampling as the Commission deems necessary, subject to the constitutions and laws of the United States and the Commonwealth. The refusal to authorize entry in connection with review of an application for a permit, Notice of Intent, Request for Determination of Applicability, or Abbreviated Notice of Resource Area Delineation shall be grounds for denial of that application.

8.6 Denials

The Commission is empowered to deny a permit or Order of Conditions or issue a positive Determination of Applicability for the following reasons:

- a. Failure to meet the requirements of this bylaw;
- b. Failure to submit necessary information and plans requested by the Commission;
- c. Failure to meet the design specifications, performance standards and/or other requirements in regulations of the Commission;
- d. Failure to meet the design specifications, performance standards and/or other requirements of the Wetlands Protection Act (G.L. c. 131 §40) and regulations (310 CMR 10.00);
- e. Failure to avoid or prevent significant or cumulative adverse effects upon the interests protected by this bylaw;
- f. The refusal to authorize entry of the Commission to a property in connection with review of an application for a permit, Notice of Intent, RDA or ANRAD; and/or
- g. Where no conditions are adequate to protect the interests of this bylaw, as determined by the Commission in its sole discretion as the issuing authority.

Any denial issued under this bylaw may differ from any such permit, Order of Conditions, denial, or Determination of Applicability issued by the Commission under the provisions of the Act, where the bylaw and regulations of the Commission are more protective of any resource area(s) than the Act.

8.7 Amendments

An applicant may request an amendment to an Order of Conditions. Any request for an amendment to an OOC shall comply with MassDEP Wetlands Program Policy 85-4, and as may be modified or amended by MassDEP.

8.8 Expiration

A permit, Order of Conditions, Determination of Applicability, or Order of Resource Area Delineation shall expire three years from the date of issuance unless otherwise specified by the Commission at the time of issuance.

8.9 Extensions

Notwithstanding the above, the Commission in its discretion may extend a permit, Order of Conditions, or Order of Resource Area Delineation for one or more periods of up to three years each, upon written request from the applicant made at least 30 days prior to the expiration of the permit Order of Conditions, or Order of Resource Area Delineation.

8.10 Revocation

For good cause the Commission may revoke or modify any permit, Order of Conditions, Order of Resource Area Delineation, or other decision issued under this bylaw after notice to the holder, the public, abutters, and after a public hearing.

8.11 Recordation of Order of Conditions or Permit

No work proposed in any application shall be undertaken until the permit, Order of Conditions, or amended Order of Conditions issued by the Commission with respect to such work has been recorded in the Southern Essex District Registry of Deeds or, if the land affected is registered land, in the registry section of the Land Court for the Southern Essex District Registry of Deeds, and until the holder of the permit, Order of Conditions, or amended Order of Conditions certifies in writing to the Commission that the document has been recorded or registered.

9. Security

As part of a permit or Order of Conditions issued under this bylaw, in addition to any security required by any other municipal or state board, agency, or official, the Commission may require that the performance and observance of the conditions imposed thereunder, including conditions requiring mitigation work, be secured wholly or in part by one or both of the methods described below:

- A. By a proper bond, a deposit of money or negotiable securities under a written third-party escrow arrangement, or other undertaking of financial responsibility sufficient in the opinion of the Commission, to be released in whole or in part upon issuance of a Certificate of Compliance for work performed pursuant to the permit.
- B. By accepting a conservation restriction, easement, or other covenant enforceable in a court of law, executed and duly recorded by the owner of record, running with the land to the benefit of the West Newbury Conservation Commission whereby the permit conditions shall be performed and observed before any lot may be conveyed other than by mortgage deed. This method of accepting a conservation restriction, easement, or other covenant shall be used only with the consent of the applicant.

10. Appeals

Any decision of the Commission issued under this bylaw and any regulations promulgated hereunder, shall be reviewable in the Essex County Superior Court in accordance with G.L. c. 249, §4.

11. Enforcement

11.1 Scope

No person shall remove, fill, dredge, build upon, degrade, or otherwise alter resource areas protected by this bylaw without the required authorization of the Commission, or cause, suffer, or allow such activity, or leave in place unauthorized fill, or otherwise fail to restore illegally altered land to its original condition, or fail to comply with a permit or an enforcement order issued pursuant to this bylaw. Any person who violates any provision of this section may be ordered to restore the property to its original condition and take other action deemed necessary to remedy such violations, or may be fined, or both.

11.2 Enforcement

The Commission, its agents, officers, and employees shall have authority to enforce this bylaw, its regulations, permits, Orders of Conditions, Orders of Resource Area Delineation, and Determinations of Applicability issued thereunder by letters, phone calls, electronic communication and other informal methods, violation notices, enforcement orders, non-criminal citations under G.L. c. 40 §21D, and civil and criminal court actions. Any person who violates provisions of this bylaw may be ordered to restore the property to its original condition and take other action deemed necessary to remedy such violations, or may be fined, or both.

11.3 Legal Action

Upon request of the Commission, the Select Board may authorize town counsel to take legal action for enforcement of this bylaw under civil law. Upon request of the Commission, the chief of police may take legal action for enforcement of this bylaw under criminal law. Municipal boards and officers, including any police officer or other officer having police powers, shall have authority to assist the Commission in enforcement.

11.4 Fines

Any person who violates any provision of this bylaw, or regulations, permits, Orders of Conditions, Orders of Resource Area Delineation, Determinations of Applicability, enforcement order, or other administrative orders issued thereunder, shall be punished by a fine set by the Commission at \$300 per violation. Each day or portion thereof during which a violation continues, or unauthorized fill or other alteration remains in place, shall constitute a separate offense, and each provision of the bylaw, regulations, permit, or administrative orders violated shall constitute a separate violation.

As an alternative to criminal prosecution in a specific case, the Commission may, in its sole discretion, issue citations with specific penalties pursuant to the non-criminal disposition procedure set forth in G.L. c. 40 §21D, which West Newbury has adopted in §XXVIII of the Bylaws of the Town of West Newbury.

As long as any person in violation demonstrates, in the sole judgement of the Commission, a reasonable, good faith effort to comply with this bylaw, the Commission may refrain from issuing fines. However, the Commission may resort to issuing fines when the violator ceases to demonstrate a reasonable, good faith effort toward achieving compliance. This provision does not preclude the Commission from exercising its prosecutorial discretion to issue fines or preclude the Commission from simultaneously ordering mitigation and/or restoration of the affected resource areas.

11.5 Appeal of Fines

In addition to the appeal provisions under G.L. c. 40, §21D, persons fined may appeal in writing to the Commission within 21 days of issuance.

11.6 Vacate Fines

The Commission may vacate fines where compliance has been established or where the issuance of fines is inconsistent with the interests of this bylaw. The Commission may suspend fines as long as the person in violation demonstrates a reasonable, good faith effort toward obtaining compliance. The Commission may restore suspended fines at any time during an existing violation. This provision does not preclude the issuance of fines in conjunction with orders for restoration or mitigation.

12. Regulations

The Commission may promulgate regulations after public notice and a public hearing to effectuate the purposes of this bylaw, effective when voted by the Commission and filed with the town clerk. At a minimum, these regulations shall reiterate the terms defined in this bylaw, define additional terms and requirements not inconsistent with the bylaw, impose filing and consultant fees, and include design specifications and performance standards which provide for undisturbed vegetative buffers extending from the edge of resource areas. Failure by

the Commission to promulgate such regulations or a legal declaration of their invalidity, in whole or in part, by a court of law shall not act to suspend or invalidate the effect of this bylaw.

13. Relation to the Wetlands Protection Act

This bylaw is adopted under the Home Rule Amendment of the Massachusetts Constitution and the Home Rule statutes, independent of the Wetlands Protection Act (G.L. c. 131 §40) and regulations (310 CMR 10.00) thereunder. It is the intention of this bylaw that the purposes, jurisdiction, authority, exemptions, regulations, specifications, standards, and other requirements shall be interpreted and administered as more protective than those of the Wetlands Protection Act (G.L. c. 131 §40) and regulations (310 CMR 10.00).

14. Severability

The invalidity of any section or provision of this bylaw shall not invalidate any other section or provision thereof, nor shall it invalidate any permit, Order of Condition, Order of Resource Area Delineation, Determination of Applicability, enforcement or other administrative orders which previously has been issued.

15. Effective Date

The effective date of this bylaw shall be the first day of the month following the approval of the bylaw by the Attorney General.

This bylaw shall not be applicable to activity that is the subject of a Notice of Intent, Request for Determination of Applicability, or Abbreviated Notice of Resource Area Delineation filed with the Commission pursuant to the provisions of the Wetlands Protection Act (G.L. c. 131 §40) and regulations (310 CMR 10.00) before the effective date of this bylaw. This bylaw shall not be applicable to activity that has been issued a permit, Order of Conditions, Order of Resource Area Delineation, or Determination of Applicability pursuant to the provisions of the Wetlands Protection Act (G.L. c. 131 §40) and regulations (310 CMR 10.00) before the effective date of this bylaw.

ARTICLE REQUEST FORM

ARTICLE: To amend the Capital Improvements Committee Bylaw for consistency with past and current practice; and to ensure no ambiguity as to oversight of expenditures from Town operating budget.

AMOUNT REQUESTED: n/a

CONTACT PERSON: Angus Jennings, Town Manager

PHONE NUMBER: 978-363-1100 ext. 115

Why should the Town make this purchase? What needs will be met? Who will benefit?

There is language in the existing Capital Improvements Committee (CIC) Bylaw that is ambiguous in its intent. The CIC's oversight has traditionally been focused on expenditures proposed from the Town's Stabilization Fund and Water Stabilization Fund, and also for expenditures from Free Cash that met other thresholds as capital projects (i.e. value >\$20k, useful life 5+ yrs, or requiring borrowing). One reading of Sec. 4 could suggest a need for the CIC review to permit expenditure of general operating funds, water operating funds, and/or other funds on "surveys, architectural or engineering advice, options or appraisal". To my knowledge, this has never been the Town's understanding nor past or current practice of the CIC. However, it is recommended that this bylaw revision be approved (as may be revised during the Board's review process) in order to clarify this potentially ambiguous language. The proposed amendments would limit the CIC's project review oversight to expenditures proposed from the Stabilization Fund, Capital Stabilization Fund and Water Stabilization Fund.

What factors affect the timing of this purchase?

In January, 2021, the Town Manager identified his concerns to the then-CIC Chair, who was supportive of introducing proposed bylaw amendments and agenda'd the topic for CIC discussion on Jan. 20, 2021. The topic came up as the final item on a lengthy agenda, for a meeting that did not adjourn until after 10pm. After some discussion, the matter was tabled. This proposal is to re-start a conversation with the current Select Board, CIC and others regarding whether the current CIC Bylaw is perfect or not.

When should this Article be sunsetted - how long will the project take?

n/a

What ancillary costs do you anticipate? (Maintenance, Insurance, Training, etc.)

None

Does this Article involve improvement, preservation or creation of tangible Town-owned assets and projects which 1) have useful life of at least five years; 2) cost over \$20,000 and or 3) for which the Town is authorized to borrow funds? If so, please confirm that this item is on the Capital Improvements Committee Schedule for future capital investments.

No

Please attach additional pages or other supporting documentation.

CAPITAL IMPROVEMENTS COMMITTEE BYLAW *[Adopted at the Special Town Meeting of October 14, 1987, approved by the Attorney General November 24, 1987, and posted according to law February 27, 1988]*

[Amendment to Capital Improvements Committee Bylaw adopted at the Special Town Meeting of January 25, 1993, approved by the Attorney General March 2, 1993, and posted according to law March 10, 1993, changed the word "Accountant" to "Finance Director" so that it reads References to the Finance Director were replaced with reference to the Town Manager by Article 19 of the Annual Town Meeting held on April 30, 2018 approved by the Attorney General on August 29, 2018 and posted according to law on October 5, 2018]

Section 1: The Board of Selectmen shall establish and appoint a committee to be known as the Capital Improvement Planning Committee, composed of one member of the Board of Selectmen, one member of the Finance Committee, and five at-large members. The representative from the Board shall be appointed by the Board for a one-year term. The Finance Committee shall appoint a representative to serve a one-year term. The five at-large members are to serve a three year rotating term. The Town Manager shall be an ex-officio member without the right to vote. The Committee shall choose its own officers.

Section 2. *{Amended by Article 16 of the Special Town Meeting held on October 16, 2016, which changed the amount of "\$10,000" to "\$20,000" which was approved by the Attorney General on September 7, 2017 and posted according to law on September 19, 2018}* The Committee shall study proposed capital projects involving the planning for and the improvement, preservation and creation of tangible assets and projects which 1) have useful life of at least five years; 2) cost over \$20,000 and or 3) for which the town is authorized to borrow funds. Capital projects shall be submitted to the Capital Improvements Committee (CIC) at a date to be established by the Committee for consideration at the following Annual Town Meeting, or four months before a Special Town Meeting, except when emergency financing is necessitated by an accident, fire, judicial order or other similar special circumstances. All officers, Boards and committees, including the Selectmen and School Committee shall give to the CIC, on forms prepared by it, information concerning all anticipated capital projects requiring Town Meeting action during the next fiscal year and five ensuing years. The Committee shall consider the relative need: impact, timing and cost of these expenditures and the effect each will have on the financial position of the town. No appropriation of Capital Stabilization or Water Stabilization Funds shall be voted for a capital improvements requested by a department, board or commission unless the proposed capital improvement is considered in the Committee's report. The Committee shall not fail to report on any proposal that has been properly submitted.

Section 3: The CIC shall prepare an annual report recommending a Capital Improvement Stabilization and Water Stabilization Budget for the next fiscal year, including any items to be funded in the current fiscal year, and a Capital Improvement Program including recommended capital improvements for the following five fiscal years. The report shall be submitted to the Board of Selectmen not later than six weeks prior to the Annual Town Meeting for its consideration and recommendations. The Board shall submit the Capital Stabilization and Water Stabilization Budget together with its recommendations to the Annual Town Meeting.

Section 4. Such Capital Improvement Program, after its adoption, shall permit the expenditure of Capital Stabilization Funds and Water Stabilization Funds on projects included therein ~~of sums from departmental budgets for surveys, architectural or engineering advice, options or appraisal~~; but no such expenditure shall be incurred on projects which have not been so approved by the town through the appropriation of sums in the current year or in prior years, ~~or for preliminary planning for projects to be undertaken more than five years in the future.~~

Section 5. The Committee's report and the Selectmen's recommended Capital Stabilization and Water Stabilization Budget shall be published and made available in a manner consistent with the distribution of the Finance Committee report. The Committee shall deposit its original report with the Town Clerk.

Source: Adapted from a form presented in the "Massachusetts Finance Committee Handbook", Stuard DeBard, Association of Town Finance Committees.

ARTICLE REQUEST FORM

ARTICLE: XX Town Meeting/Elections: Votes to be declared by Moderator

AMOUNT REQUESTED: N/A

CONTACT PERSON: James Blatchford

PHONE NUMBER: 978-363-1100 x110

Why should the Town make this purchase? What needs will be met? Who will benefit?

The Moderator may take all votes requiring a two-thirds majority in the same manner in which they conduct the taking of a vote when a majority vote is required.

What factors affect the timing of this purchase?

N/A

When should this Article be sunsetted - how long will the project take?

N/A

What ancillary costs do you anticipate? (Maintenance, Insurance, Training, etc.)

N/A

Does this Article involve improvement, preservation or creation of tangible Town-owned assets and projects which 1) have useful life of at least five years; 2) cost over \$20,000 and or 3) for which the Town is authorized to borrow funds? If so, please confirm that this item is on the Capital Improvements Committee Schedule for future capital investments.

N/A

Please attach additional pages or other supporting documentation.

ARTICLE REQUEST FORM

ARTICLE: Amendments and Additions to Zoning Definitions

AMOUNT REQUESTED: \$0.00

CONTACT PERSON: Sam Joslin

PHONE NUMBER: 978-618-4430

Why should the Town make this purchase? What needs will be met? Who will benefit?

The purpose of this zoning amendment is to update definitions, primarily to bring these into alignment with building code definitions.

What factors affect the timing of this purchase?

N/A

When should this Article be sunsetted - how long will the project take?

N/A

What ancillary costs do you anticipate? (Maintenance, Insurance, Training, etc.)

None

Does this Article involve improvement, preservation or creation of tangible Town-owned assets and projects which 1) have useful life of at least five years; 2) cost over \$20,000 and or 3) for which the Town is authorized to borrow funds? If so, please confirm that this item is on the Capital Improvements Committee Schedule for future capital investments.

N/A

Please attach additional pages or other supporting documentation.

SECTION 2. DEFINITIONS

For the purposes of this by-law certain terms and words are herein defined as follows:

Words used in the present tense include the future; words in the singular number include the plural and words in the plural number include the singular; the word "shall" is mandatory and not directory; the word "lot" includes the word "plot"; the word "land" includes the words "marsh" and "water".

~~Accessory Building. A building not attached to any principal building, customarily incidental to and located on the same lot with the principal building. [Amended by vote of Annual Town Meeting, Article 13, effective November 4, 2019, and approved by the Attorney General on November 1, 2021 and posted according to law on November 4, 2021]~~

Commented [SJ1]: Delete and replace with Accessory Structure

Accessory Structure. A structure that is accessory to and incidental to that of dwelling(s) and that is located on the same lot

Commented [SJ2]: BC definition

Accessory Use. A use subordinate and customarily incidental to the principal use and located on the same lot as the principal use. [Amended by vote of Annual Town Meeting, Article 13, effective November 4, 2019, and approved by the Attorney General on November 1, 2021 and posted according to law on November 4, 2021]

Addition. An extension or increase in floor area, number of stories or height of a building or structure.

Commented [SJ3]: BC definition

Adult Use. Adult use shall mean any of the following adult uses as separate or combined entities or activities. (1) Adult bookstore: an establishment having a substantial or significant portion of its stock in trade, books, magazines, and other matter which are distinguished or characterized by their emphasis depicting, describing or relating to "Sexual conduct" or "Sexual excitement" as defined by MGL Chapter 272, Section 31; (2) Adult video store: an establishment having a substantial or significant portion of its stock in trade videos, movies, CD-ROM, DVD or similar technologies that provide images to be viewed on or off premises which are distinguished or characterized by their emphasis depicting, describing or relating to "Sexual excitement" or "Sexual conduct" as defined in MGL Chapter 272, Section 31; (3) Adult paraphernalia store: an establishment having a substantial or significant portion of its stock, devices, objects, tools or toys which are distinguished or characterized by their association with sexual conduct or sexual excitement as defined by MGL Chapter 272, Section 31; (4) Adult motion picture theater: a building or structure used for presenting material distinguished by an emphasis on matter depicting, describing or relating to sexual conduct or sexual excitement as defined by MGL Chapter 272 Section 31; (5) Adult live entertainment establishment: any establishment which displays live entertainment which is distinguished or characterized by its emphasis depicting, describing or relating to sexual conduct or sexual excitement as defined by MGL Chapter 272 Section 31.

Animal Hospital or Veterinary. Facilities for keeping animals to be treated, in treatment or recovering from treatment in accord with normal veterinary practice as established by the Massachusetts Board of Registration of Veterinary Medicine.

~~Apartment. A dwelling unit which occupies a part of a building, other parts of which may or may not be used as dwellings.~~

Commented [SJ4]: Only used in industrial district relating to an onsite caretaker unit. Language in this section can be changed from "Apartment" to "attached Dwelling Unit"

~~Apartment House. A building arranged, intended or designed to be occupied by two or more families living independently of each other.~~

Commented [SJ5]: Delete. Not use in bylaw

Assisted Living Facility. A managed residential community, operating under provisions of -MGL Chapter 19D and contained in one or more primary buildings consisting of private residential units with or without kitchens. Further, said facilities may provide assistance with activities of daily living, together

with meal service, housekeeping services, social and recreational activities and personal care services, transportation services, in a group setting primarily limited to individuals 62 years and older or couples,

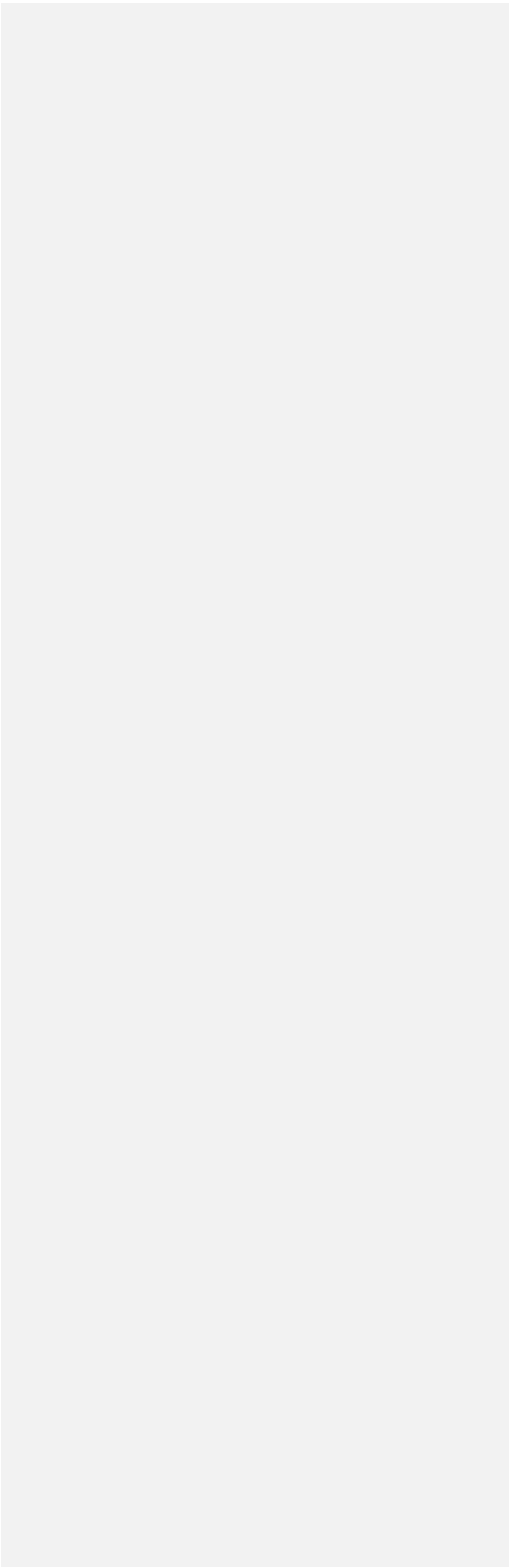

one of whom is at least 62 years of age, who require help or assistance with activities of daily living but do not require full time nursing care.

~~ATM/Automatic Teller Machine. A drive in or walk in banking facility which either stands as a single structure or is attached to another building.~~

Commented [SJ6]: Definition serves no purpose in the bylaw as the use is described in the section relating to banks/ATMs

~~Basement. The part of the building which is wholly or partly below ground level. A story that is not a story above grade plane (see "story above grade plane")~~

Commented [SJ7]: BC definition

~~Basement, Finished [Deleted, by vote of Annual Town Meeting, Article 13, effective November 4, 2019 and approved by the Attorney General on November 1, 2021 and posted according to law on November 4, 2021]~~

~~Bed and Breakfast. A house, or portion thereof, where up to four lodging rooms, with meals, are provided providing that the maximum duration of any tenant shall be less than 14 consecutive nights. The operator shall live on the premises, or in an adjacent premises immediately abutting the residence with the bed and breakfast facility. [Amended by vote of Annual Town Meeting, Article 24, effective October 18, 2020, and approved by the Attorney General on January 25, 2022 and posted according to law on April 1, 2022]~~

Commented [SJ8]: Is this a use we want to retain?

~~Boarding House. A building or premises, other than a hotel or bed & breakfast, for not more than four (4) persons, provided that the principal use is as a private residence, where rooms are let and where meals may be regularly served by prearrangement for compensation; not open to short term paying guests. [Amended by vote of Annual Town Meeting, Article 24, effective October 18, 2020, and approved by the Attorney General on January 25, 2022 and posted according to law on April 1, 2022]~~

Commented [SJ9]: State uses "lodging house" vs "boarding house". Change in language needed in Section 5.A.2.c.iii

~~Building. A structure having a roof or cover for the shelter, housing, or permanent habitation for one (1) or more persons. Any structure used or intended for supporting or sheltering any use or occupancy.~~

Commented [SJ10]: BC definition

~~Building Inspector/ Building Official. See Inspector of Buildings/Building Commissioner.~~

Commented [SJ11]: Terms used in MGL BC and Bylaws. This will clarify and capture the use of all terms associated with the Building inspector

~~Building Lot or Lot. [Deleted, by vote of Annual Town Meeting, Article 13, effective November 4, 2019 and approved by the Attorney General on November 1, 2021 and posted according to law on November 4, 2021]~~

~~Cemetery. An area of land for the interment of human remains.~~

~~Child Care Center. A child care center or school age child care program as defined in Massachusetts General Laws Chapter 15D, Section 1A. [Amended by vote of Annual Town Meeting, Article 13, effective November 4, 2019, and approved by the Attorney General on November 1, 2021 and posted according to law on November 4, 2021]~~

Commented [SJ12]: Term only found in definitions

~~Cluster Zoning. [Deleted, by vote of Annual Town Meeting, Article 13, effective November 4, 2019 and approved by the Attorney General on November 1, 2021 and posted according to law on November 4, 2021]~~

~~Condominium. A system of real estate ownership in which a person or persons, partnership or corporation own one or more units or parcels in a multi-unit structure or parcel of land plus an undivided interest in elements and/or components owned jointly by all of the unit or parcel owners, or as defined in Chapter 183A of the General Laws.~~

Congregate Housing. A group living arrangement for elderly persons and persons with disabilities who cannot easily maintain their own housing, financially or otherwise, but who do not need nursing home care. The persons living together may care for themselves or may have ~~some~~ support services. *[Amended by vote of Annual Town Meeting, Article 24, effective October 18, 2020, and approved by the Attorney General on January 25, 2022 and posted according to law on April 1, 2022]*

~~Cooperative. A system of ownership in which shares in a corporation are owned, entitling an owner or owners to occupancy of a portion of real estate owned by the corporation.~~

Commented [SJ13]: Term only found in definitions

Contiguous and Buildable Area. See Section 6.A.2. *[Amended by vote of Annual Town Meeting, Article 13, effective November 4, 2019, and approved by the Attorney General on November 1, 2021 and posted according to law on November 4, 2021]*

Corner Lot. A lot abutting two or more public or private ways at their intersection. *[Amended by vote of Annual Town Meeting, Article 13, effective November 4, 2019, and approved by the Attorney General on November 1, 2021 and posted according to law on November 4, 2021]*

Cul-de-sac. A ~~dead-end~~~~dead-end~~ street with the closed end consisting of a turn around. Refer to the West Newbury Planning Board Rules and Regulations Governing the Subdivision of Land, as may be amended. *[Amended by vote of Annual Town Meeting, Article 13, effective November 4, 2019, and approved by the Attorney General on November 1, 2021 and posted according to law on November 4, 2021]*

Dwelling. Any building, or part thereof, used for habitation for one (1) or more persons, but not including commercial accommodations for transient occupancy or trailers or mobile homes, however mounted.

Dwelling Unit. ~~One (1) or more rooms with cooking, living, sanitary and sleeping facilities arranged for the use of one (1) or more persons living together as a single housekeeping unit.~~
A single unit providing complete independent living facilities for one or more persons, including permanent provisions for living, sleeping, eating, cooking and sanitation.

Commented [SJ14]: BC definition

Family. One (1) or more persons living together in one dwelling unit, but not including sororities, fraternities and other communal arrangements.

Family Day Care. A day care facility for not more than six children located in a building in which the primary purpose is residential.

Farming. The use of land for agriculture as defined in Massachusetts General Laws Chapter 128, Section 1.A., as may be amended. *[Amended by vote of Annual Town Meeting, Article 13, effective November 4, 2019, and approved by the Attorney General on November 1, 2021 and posted according to law on November 4, 2021]*

Commented [SJ15]: Change Farm to Farming. Farming is defined in the MGL cited. Farming is a better descriptor for all uses allowed under the MGL

Floor Area. Floor area shall be the cumulative floor area, of all levels within the perimeter of the outside walls of the building under consideration, without deduction for hallways, stairs, closets, thickness of walls, columns or features. In the case of a multi-unit building, the center of the common wall shall be included.

Commented [SJ16]: Changed for clarification

Frontage. The linear extent of a lot measured along a constructed street ~~right-of-~~ or way from the intersection of one side lot line to the intersection of the other side lot line of the same lot, which can be used for access to the lot but not including any portion thereof devoted to a right-of-way or a driveway serving more than one lot unless a special permit for a common driveway has been approved by the Planning Board.

Frontage at corner lot. ~~At a corner, frontage shall be measured to the point of intersection of the extension of the sideline of the rights of way. (see diagram in Appendix One).~~ *[Amended by vote of the Annual Town Meeting, second session, on May 6, 2009, approved by the Attorney General on August 11, 2009 and posted according to law on August 24-20, 2009]* Frontage for a corner lot shall be measured on the side of the lot that will be used to access the property and the proposed construction will front on.

Commented [SJ17]: Clarification of language and elimination of diagram.

Frontage on Curved Streets and in Cul-De-Sacs. For lots fronting on curved streets and cul-de-sacs, the frontage distance shall be determined by measuring the cumulative linear distances along the curves and any tangent sections there between, where the lot fronts on the street. ~~See diagram in Appendix One.~~ *[Added by vote of the Annual Town Meeting of April 30, 2007, approved by the Attorney General on June 11, 2007 and posted according to law on June 25, 2007.]*

Commented [SJ18]: Clarification of language and elimination of diagram.

Garage, Private. Covered space for the housing of motor vehicles, but not for the rental of more than two (2) stalls or for commercial repair of vehicles or commercial storage of vehicles.

Garage, Public. Any garage other than a private garage, available to the public, operated for gain, and which is used for storage, repair, rental, greasing, washing, servicing, adjusting or equipping of automobiles or other motor vehicles, or supplying of gasoline or oil to motor vehicles.

Gasoline Station. An establishment which provides for the refueling of and servicing of motor vehicles and operations incidental thereto, and may include facilities for lubricating, washing or otherwise servicing motor vehicles, but not including the painting thereof by any means.

Commented [SJ19]: Left out the one thing gas stations are know for

Hazardous Materials. A substance or solid material in a quantity or form that significantly contributes to serious illness or death, or that poses a substantial threat to human health or poses an unreasonable risk to health, safety, property or the environment when improperly managed, including all materials listed as hazardous by the Environmental Protection agency, under the Toxic Substance Control Act, Federal Resource Conservation and Recovery Act or similar authority, the Department of Energy or the Commonwealth of Massachusetts pursuant to applicable General Laws.

Hotel. A building, or portion thereof, or a group of buildings on a single lot, intended to be used for the temporary occupancy of ~~three (3) or more short term~~ short-term paying guests ~~who are lodged~~, with or without meals, and in which major provision for cooking may be made in a central kitchen but may not be in the individual rooms or suites. *[Amended by vote of Annual Town Meeting, Article 24, effective October 18, 2020, and approved by the Attorney General on January 25, 2022 and posted according to law on April 1, 2022]*

Inspector of Buildings/ Building Commissioner. The administrative chief of the building department in a municipality who is charged with the enforcement of 780 CMR in accordance with M.G.L. c. 143 §§ 3 and 3A as well as the enforcement of the Zoning-By- Law.

Commented [SJ20]: For clarification

Kennel. Facilities for keeping four (4) or more dogs three (3) months old or older on a single premises, whether maintained for breeding, boarding, sale, training, hunting or other purposes and including any shop where dogs are customarily kept for sale.

~~Kindergarten. A school or class of young children, usually from four (4) to six (6) years of age.~~

Commented [SJ21]: Term only found in definitions

Loading Space, Off-Street. An off-street space or berth, on the same lot with a building, for the temporary parking of vehicles while loading or unloading merchandise or material, and which has

Commented [SJ22]: Removed "berth" as it is typically a term used for ships

access to a street or other appropriate means of ingress or egress.

Lodging House. A one-family dwelling where one or more occupants are primarily permanent in nature and rent is paid for guest rooms.

Commented [SJ23]: Replaced "boarding house" to be consistent with BC

Lot. An area of land in single ownership with definite boundaries, established by a recorded plan or deed, including a lot created by combining several previously recorded lots, and used or available for use as the site of one or more buildings or for any other purpose. *[Amended by vote of Annual Town Meeting, Article 13, effective November 4, 2019, and approved by the Attorney General on November 1, 2021 and posted according to law on November 4, 2021]*

Lot Area. ~~The area of a lot exclusive of any area in a street or way, public or private. *[Added by vote of the Annual Town Meeting of April 30, 2007, approved by the Attorney General on June 11, 2007 and posted according to law on June 25, 2007.]*~~ The area of the horizontal plane of a parcel of land bounded by the front, side and rear lot lines.

Commented [SJ24]: Changed for clarification

Lot Width. The shortest distance between the side lot lines of the lot measured at the minimum front set back line.

Commented [SJ25]: Added for clarity

Maximum Building Coverage. The maximum permissible area that may be covered by the ground floor area of all buildings, portions or that building and appurtenances on a lot when viewed from above; to be measured as a percent of the required minimum lot area in the zoning district where the lot is located.

Commented [SJ26]: Changed for clarification

Maximum Lot Coverage. The maximum permissible area that may be covered by all impervious surfaces on a lot, such as but not limited to buildings, pools, paved tennis courts, paved driveways and walkways; to be measured as a percent of the required minimum lot area in the zoning district.

Membership Club. A private, non-profit organization, building or grounds, to include specifically country clubs and fraternities and other organizations to which membership is limited or controlled.

Mobile Home. Any vehicle or object, which is drawn by or used in connection with a motor vehicle and which is so designed and constructed or reconstructed or added to by means of such accessories as to permit the use and occupancy thereof for human habitation, whether resting on wheels, jacks, or other foundations. It shall include the type of vehicle or modular construction commonly known as a mobile home, containing complete electrical, plumbing, and sanitary facilities and designed to be installed on a temporary or permanent foundation for permanent living quarters.

Municipal Buildings and Use. Facilities owned by the Town of West Newbury, operated by the Town of West Newbury, or both, and the uses conducted therein. *[Added by vote of Annual Town Meeting, Article 13, effective November 4, 2019, and approved by the Attorney General on November 1, 2021 and posted according to law on November 4, 2021]*

Non-Conforming Lot. A non-conforming lot is an existing lawful lot, which does not conform to the regulations for the district in which it is located and which existed at the time of the publication of notice of the hearing before the Planning Board respecting the regulation to which it does not conform as described in M.G.L. 40A § 6.

Commented [SJ27]: Changed to link qualifications to state zoning

Non-Conforming Use. A non-conforming use of land or building is an existing lawful use of land or building which does not conform to the regulations for the district in which such use of land or building exists and which existed at the time of publication of notice of the hearing before the Planning Board respecting the regulation to which it does not conform as described in M.G.L. 40A § 6.

Commented [SJ28]: Changed to link qualifications to state zoning

~~Nursery School. A place for group pre-school training of children.~~

Commented [SJ29]: Term only found in definitions

Open Space Preservation Development A residential development in conformance with the Section 6.B, in which the buildings and accessory uses are clustered together into one or more groups separated from

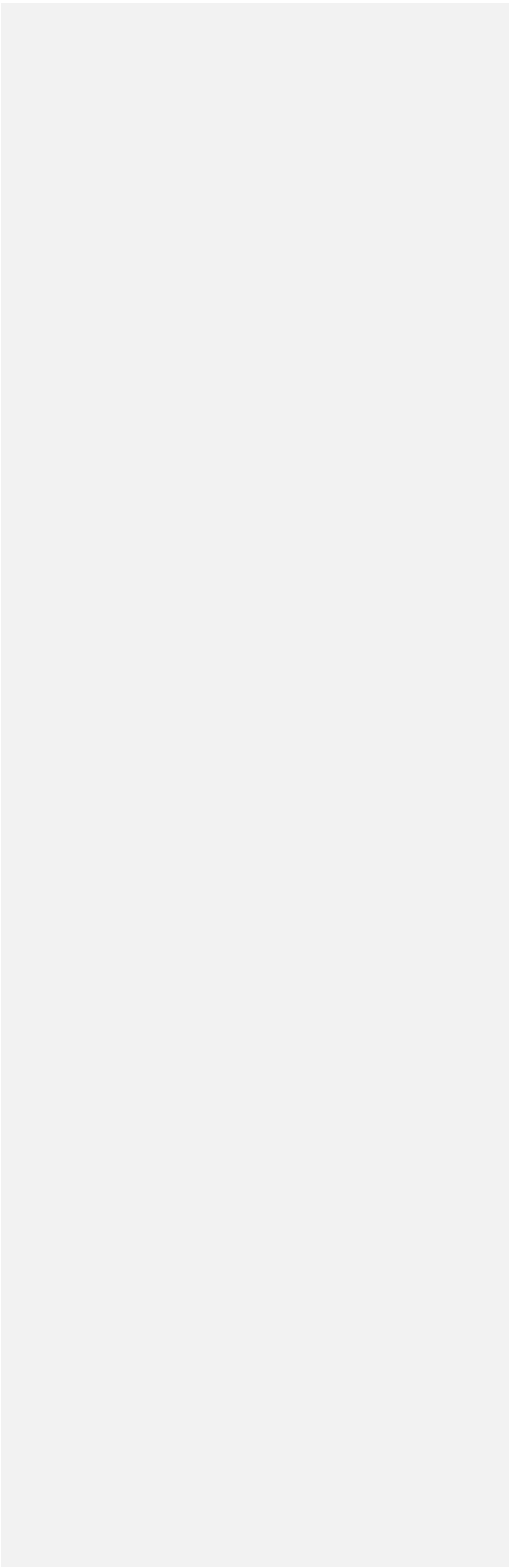

adjacent property and from other groups in the same development by intervening open land, and in which the minimum dimensional requirements of lots are reduced and the land gained thereby is preserved as open space. *[Amended by vote of Annual Town Meeting, Article 13, effective November 4, 2019, and approved by the Attorney General on November 1, 2021 and posted according to law on November 4, 2021]*

Principal Building. A building in which the primary use of the lot on which the building is located is conducted.

Principal Use. The ~~main~~ primary use of land or structures on a lot, as determined by the Inspector of Buildings.

Commented [SJ30]: Changed for consistency

Screened Area. A section shielded from view from adjacent areas by fencing, hedges or trees.

Commented [SJ31]: Term only used in definitions

Screening. The material used to shield an area from view.

~~Short Term~~ Short-Term Paying Guest. A person who rents a room in a hotel or bed & breakfast for less than 14 consecutive nights. *[Amended by vote of Annual Town Meeting, Article 24, effective October 18, 2020, and approved by the Attorney General on January 25, 2022 and posted according to law on April 1, 2022]*

Sign. Any words, lettering, parts of letters, figures, numerals, phrases, sentences, emblems, devices, designs, trade names, or trademarks, whether stationary or portable, by which anything is made known, such as are used to designate or locate an individual, a firm, an association, a corporation, a profession, a business, or a commodity or product, which are visible from a public or private street or right-of-way and used to attract attention.

~~Stream~~ Bank of. ~~Rising ground bordering a flowing body of water as defined in 310 CMR 10 of Massachusetts Regulations.~~

Commented [SJ32]: Term only used in definitions

Street. A public way or a private way either shown on a plan approved in accordance with the subdivision control law, or otherwise qualifying a lot for frontage under the subdivision control law.

Street Line. The dividing line between a street and a lot and, in the case of a public way, the street line established by the public authority laying out the way upon which the lot abuts.

Structure. ~~Any construction, erection, assemblage or other combination of materials upon the land, necessitating pilings, footings or a foundation for attachment to the land including swimming pools two (2) feet or more deep or having a surface of seventy-five (75) or more square feet and including all swimming pools permanently equipped with a water circulating system.~~ That which is built or constructed.

Commented [SJ33]: BC definition

Swimming Pool. ~~An artificial pool of water or a natural pool altered to have a depth of two (2) feet or more at any point or seventy-five (75) or more square feet of surface and used for swimming or bathing, located indoors or outdoors, together with the equipment, and appurtenances used in connection with the pool.~~

Commented [SJ34]: Delete definition and delete from listed uses. This will fall to requirements for accessory structures for zoning and to the BC as to how to construct it

Town House. ~~A single family dwelling attached to another single family dwelling, in such a manner that each dwelling has a floor at ground level and front and rear access to the outside.~~

Commented [SJ35]: Term only found in definitions.

Trailer. Any vehicle or object which is drawn by a motor vehicle.

Veterinary. See Animal Hospital

Wetlands. Swamps, bogs and freshwater wetlands as defined by Chapter 131, Section 40 of the General Laws of the Commonwealth of Massachusetts. *[Amended by vote of Annual Town Meeting, Article 13, effective November 4, 2019, and approved by the Attorney General on November 1, 2021 and posted according to law on November 4, 2021]*

Yard. An open space, other than an enclosed court, on the same lot with a building or group of buildings, which open space lies between the building or group of buildings and a lot line, and is not occupied or obstructed from the ground upward by a building or a structure, except for fences.

Yard, Front. A yard extending across the full width of the lot and lying between the street line of the lot and the nearest line of the building. The depth of a front yard shall be the minimum distance between the building and the front lot line.

Yard, Rear. A yard extending across the full width of the lot and lying between the rear lot line of the lot and the nearest line of the building. The depth of a rear yard shall be the minimum distance between the building and the rear lot line.

Yard, Side. A yard between the side lot line of the lot and the nearest line of the building, and extending from the front yard to the rear yard, or, in the absence of either of such yards, to the front or rear lot lines, as may be. The width of a side yard shall be the minimum distance between the building and the side lot line.

ARTICLE REQUEST FORM

ARTICLE: Police Special Detail Work Fund

AMOUNT REQUESTED: N/A

CONTACT PERSON: Jennifer Walsh, Town Accountant

PHONE NUMBER: 978-363-1100 x112

Why should the Town make this purchase? What needs will be met? Who will benefit?

To see if the Town will vote to establish a special purpose fund pursuant to M.G.L. c. 44, s. 53C to be known as the Special Detail Work Fund.

What factors affect the timing of this purchase?

When should this Article be sunsetted - how long will the project take?

N/A

What ancillary costs do you anticipate? (Maintenance, Insurance, Training, etc.)

Does this Article involve improvement, preservation or creation of tangible Town-owned assets and projects which 1) have useful life of at least five years; 2) cost over \$20,000 and or 3) for which the Town is authorized to borrow funds? If so, please confirm that this item is on the Capital Improvements Committee Schedule for future capital investments.

N/A

Please attach additional pages or other supporting documentation.

ARTICLE REQUEST FORM

ARTICLE: Revocation of the dedication of revenues to the Opioid Settlement Stabilization Fund

AMOUNT REQUESTED: \$3,846.12

CONTACT PERSON: Jennifer Walsh, Town Accountant

PHONE NUMBER: 978-363-1100 ext 112

Why should the Town make this purchase? What needs will be met? Who will benefit?

To see if the town will vote to revoke its acceptance of the fourth paragraph of Massachusetts General Laws Chapter 40, Section 5B, which allows the dedication, without further appropriation, of all of the receipts from settlements on behalf of the Town with persons and entities involved in the sale, distribution and manufacture of opioid products to be effective for the fiscal year beginning on July 1, 2024; and, to transfer prior year settlement funds in the amount of \$3,846.12 that have become part of free cash into a special revenue fund.

What factors affect the timing of this purchase?

On December 4, 2023, Governor Healey signed Chapter 77 of the Acts of 2023, Section 9 of which provides, in part, for the following exception to the general rule that all receipts are to be recorded as general fund revenue per G.L. c. 44, § 53:

"(4) non-recurring, unanticipated sums received by multiple cities, towns or districts and not otherwise provided for by general or special law, may, upon the approval of the director of accounts, be expended at the direction of the chief executive officer without further appropriation only for the singular purpose for which the monies were received" (emphasis added)

The Director of Accounts has determined that cities and towns that have received or will receive funds in Fiscal Year 2024, or thereafter, pursuant to settlement agreements entered into by the Commonwealth with opioid distributors and opioid-makers for prevention, harm reduction, treatment, and recovery, may place said funds into a special revenue fund. The proceeds can then be expended, without further appropriation, at the direction of the chief executive officer only for the purpose identified in said settlement agreements.

Section 197 of the Act further provides ways for a community to consolidate all monies previously received for this purpose into the special revenue fund, mentioned above.

Settlement funds that have become part of free cash may be appropriated into the special revenue fund by vote of the community's legislative body.

Once placed in the special revenue fund, monies can be spent without further appropriation for purpose identified in the settlement agreements. Any interest belongs to the general fund.

The transfer of funds, noted above, represents a limited ability to consolidate previously received opioid settlement monies into the newly allowed special revenue fund. These transfers are permitted only for this express purpose and should not be considered a general change to how monies are otherwise accounted for under the General Laws.

When should this Article be sunsetted - how long will the project take?

N/A

What ancillary costs do you anticipate? (Maintenance, Insurance, Training, etc.)

N/A

Does this Article involve improvement, preservation or creation of tangible Town-owned assets and projects which 1) have useful life of at least five years; 2) cost over \$20,000 and or 3) for which the Town is authorized to borrow funds? If so, please confirm that this item is on the Capital Improvements Committee Schedule for future capital investments.

N/A

Please attach additional pages or other supporting documentation.



Bulletin

BUL-2023-8

RECENT LEGISLATION

TO: Local Officials

FROM: Kenneth Woodland, Chief, Municipal Finance Law Bureau

DATE: December 2023

SUBJECT: "AN ACT MAKING APPROPRIATIONS FOR THE FISCAL YEAR 2023 FOR SUPPLEMENTING CERTAIN EXISTING APPROPRIATIONS AND FOR CERTAIN OTHER ACTIVITIES AND PROJECTS" Chapter 77 of the Acts of 2023

To keep you informed of legislative developments, the Division of Local Services ("Division") periodically publishes a **BULLETIN** summarizing new laws that affect municipal budgets and local tax assessment, administration and collection. Each issue usually contains a cumulative summary of session laws enacted to that time and indicates whether the Division has issued any further implementation guidelines. This edition of the **BULLETIN** instead focuses on a recent legislative change affecting municipal finance found in Chapter 77 of the Acts of 2023 ("Act"), entitled AN ACT MAKING APPROPRIATIONS FOR THE FISCAL YEAR 2023 FOR SUPPLEMENTING CERTAIN EXISTING APPROPRIATIONS AND FOR CERTAIN OTHER ACTIVITIES AND PROJECTS. The Act is currently in effect.

§ 8 of the Act amends G.L. c. 40, § 5B, which governs the establishment of stabilization funds and regulates their administration. As is the practice in many cities and towns, municipalities may create a general purpose stabilization fund or a special purpose stabilization fund. In practice, most general purpose stabilization funds are broadly created for any lawful purpose while a special purpose stabilization fund delineates the intent of future expenditures more distinctly. The Act changed the quantum of votes to appropriate funds from special purpose stabilization funds so that it is now a simple majority. The present two-thirds quantum of votes needed for appropriating funds from a general purpose stabilization remains the same. Likewise, a two-thirds vote is still needed to create either stabilization fund or to change its purpose.

§ 9 of the Act amends G.L. c. 44, § 53, which governs municipal receipts, in the following two ways.

First, Clause 2 has been amended. Presently, a municipal or district department in charge of property that was damaged and for which the municipality or district receives insurance proceeds or restitution payments of \$150,000 or less could spend the monies, without appropriation and with the approval of the chief executive officer, to replace or repair the property. In many cases, however, that replacement or repair must be made immediately. The change now allows spending for this purpose in advance of the monies being received, for amounts \$150,000 or less. However, if the monies are not received by the close of the fiscal year after the fiscal year in which the damage occurred, the municipality must report the same in the determination of the applicable annual tax rate or otherwise make provision therefor. The amendment is patterned after the change made by the Municipal Modernization Act to G.L. c. 44, § 53A, which allows spending in advance of certain grant funds.

Second, new Clauses 4 and 5 have been added. Generally, all money received or collected from any source by a city, town or district belongs to its general fund and can only be spent after appropriation unless a general or special law provides an exception, i.e., expressly restricts use for a particular purpose or allows expenditure by a department or officer without appropriation. This general rule of municipal finance occasionally presents communities with accounting and procedural difficulties in situations where an unexpected, conditional receipt is received. Such receipts, by law, would become part of the general fund, eventually close and become part of the next year's free cash certification. When it becomes part of free cash, the original restrictions on the funds become muddled, as under current law they must sit in an available fund that can be appropriated for any lawful purpose. Additionally, this process can take several months and many times these one-time monies are intended for immediate expenditure for their specific purpose. The new Clauses 4 and 5 create exceptions to this general rule. With the approval of the Director of Accounts, in certain circumstances, both clauses allow certain one-time monies to be reserved in a special revenue fund, thereby not closing to fund balance at the end of the fiscal year and not becoming part of the free cash certification. Clause 4 does so for monies received for one specific purpose and can be spent without further appropriation, while Clause 5 does so for monies received for multiple purposes and requires appropriation. In both scenarios, there must be an authorization from the Director of Accounts and is limited to one-time, unanticipated receipts that affect multiple communities.

To see how this change, pursuant to Clause 4, will impact opioid settlement receipts, please see Bulletin 2023-7. The Bulletin further discusses Section 197 of the Act which allows a community to consolidate all monies previously received for this purpose into the special revenue fund in the ways described therein.

Next, § 10 of the Act inserts new section 53K into G.L. c. 44. Municipalities often enter into host or mitigation agreements with developers or other entities, including cannabis establishments and casinos, to address the impacts of new development or location of a facility within the city or town and receive cash payments to mitigate these impacts. In addition, a developer may make a cash payment in lieu of undertaking a particular condition or obligation required by a zoning or other permitting by-law or ordinance, or a party renting municipal property may make payments in addition to the lease. Examples include a developer of a commercial property making a payment required under the town's zoning bylaw in lieu of constructing sufficient parking spaces with the monies to be used by the town for the acquisition, improvement and maintenance of municipal parking; or a cell phone company that is leasing town owned property for its equipment agreeing to give the municipality a "one-time payment" in addition to its lease. Under current municipal finance law, these mitigation payments or regulatory exactions are general fund monies that must be appropriated before they can be used for the dedicated

purposes for which they are given and received. G.L. c. 44, § 53. The parties often try to characterize the monies as gifts, so as to be able to spend them without appropriation, but they are not gifts within any ordinary meaning of the term. The new § 10 addition of Section 53K allows communities to separately account for such payments in a special revenue fund and spend them for the dedicated purposes without further appropriation.

Lastly, § 205 of the Act allows a city or town to amortize over fiscal years 2025 to 2027 the amount of its fiscal year 2024 major disaster related deficit. To do so, the select board or, in a city, the council, with the mayor's approval when required by law, must adopt a deficit amortization schedule before setting the municipality's fiscal year 2025 tax rate. The amortization process will be comparable to the process that was used to amortize snow related deficits in 2015. Examples of a major disaster include flood, drought, fire, hurricane, earthquake, storm or other catastrophe, whether natural or otherwise, which poses an immediate threat to the health or safety of persons or property. To utilize this section, there must be a declaration of emergency, either locally or by the Governor, and an approval to expend for the liabilities incurred by the Director of Accounts. DLS will be providing further guidance on this process.

ARTICLE REQUEST FORM

ARTICLE: Establish Capital Stabilization Fund pursuant to MGL Ch. 40 Sec. 5B

AMOUNT REQUESTED: n/a

CONTACT PERSON: Angus Jennings, Town Manager

PHONE NUMBER: 978-363-1100 ext. 115

Why should the Town make this purchase? What needs will be met? Who will benefit?

Over many years, the Town has largely considered the existing Stabilization Fund to be a Capital Stabilization Fund. However, the existing Stabilization Fund is a general purpose fund, and its use is not restricted to Capital projects. It is proposed to establish a separate Capital Stabilization Fund - which would be so restricted - and then, in subsequent Town Meetings, to transfer and/or appropriate an amount of funds sufficient to satisfactorily finance the Town's long-term Capital Improvements Program.

What factors affect the timing of this purchase?

The Town Manager views this as largely a housekeeping item, and would result in a chart of accounts that more accurately represents to taxpayers what balances are restricted for Capital projects and what balances may legally be appropriated (by Town Meeting) for any lawful purpose. The current situation is not a "problem", and could continue with no ill effects for the foreseeable future. However, in the event that Town Meeting were asked to consider a non-capital expenditure from the current Stabilization Fund before the account structure is changed, it could result in voter confusion or surprise that the current Stabilization Fund is not restricted to Capital projects. The Finance Committee Chair has identified the creation of a separate Capital Stabilization Fund as a high priority for his Committee.

When should this Article be sunsetted - how long will the project take?

n/a

What ancillary costs do you anticipate? (Maintenance, Insurance, Training, etc.)

None

Does this Article involve improvement, preservation or creation of tangible Town-owned assets and projects which 1) have useful life of at least five years; 2) cost over \$20,000 and or 3) for which the Town is authorized to borrow funds? If so, please confirm that this item is on the Capital Improvements Committee Schedule for future capital investments.

None

Please attach additional pages or other supporting documentation.

Part I	ADMINISTRATION OF THE GOVERNMENT
Title IX	TAXATION
Chapter 59	ASSESSMENT OF LOCAL TAXES
Section 5N	REDUCTION OF PROPERTY TAX OBLIGATION OF VETERAN IN EXCHANGE FOR VOLUNTEER SERVICES

Section 5N. In any city or town which accepts this section, the board of selectmen of a town, or in a municipality having a town council form of government, the town council or the mayor, with the approval of the city council in a city, may establish a program to allow veterans, as defined in clause Forty-third of section 7 of chapter 4 or a spouse of a veteran in the case where the veteran is deceased or has a service-connected disability, to volunteer to provide services to that city or town. In exchange for such volunteer services, the city or town shall reduce the real property tax obligations of that veteran on the veteran's tax bills and that reduction shall be in addition to any exemption or abatement to which that person is otherwise entitled; provided, however, that person shall not receive a rate of, or be credited with, more than the current minimum wage of the commonwealth per hour for the services provided pursuant to that reduction; and provided further, that the reduction of the real property tax bill shall not exceed \$1,500 in a given tax year. It shall be the responsibility of the city or town to maintain a record for each taxpayer including, but not limited to, the number of hours of service and the total

amount by which the real property tax has been reduced and to provide a copy of that record to the assessor in order that the actual tax bill reflect the reduced rate. A copy of that record shall also be provided to the taxpayer prior to the issuance of the actual tax bill. The cities and towns shall have the power to create local rules and procedures for implementing this section in a way that is consistent with the intent of this section. Nothing in this section shall be construed to permit the reduction of workforce or otherwise replace existing staff.

The amount by which a person's property tax liability is reduced in exchange for the volunteer services shall not be considered income, wages or employment for purposes of taxation as provided in chapter 62, for the purposes of withholding taxes as provided in chapter 62B, for the purposes of workers' compensation as provided in chapter 152 or any other applicable provisions of the General Laws. While providing such volunteer services, that person shall be considered a public employee for the purposes of chapter 258 and those services shall be deemed employment for the purposes of unemployment insurance as provided in chapter 151A.

A city or town, by vote of its legislative body, subject to its charter, may adjust the exemption in this clause by: (i) allowing an approved representative for persons physically unable to provide such services to the city or town; or (ii) allowing the maximum reduction of the real property tax bill to be based on 125 volunteer service hours in a given tax year, rather than \$1,500.

TOWN OF WEST NEWBURY
TOWN MEETING CITIZEN PETITION ARTICLE FORM

While not required, this form is the preferred method for a citizen to insert an Article on the Warrant for Town Meeting

2024 JAN 18 PM 3:30

RECEIVED
TOWN CLERK
WEST NEWBURY, MA

IMPORTANT

1. Petitioner should consult with someone knowledgeable in municipal government, such as a lawyer, the Town Manager, or the Town Moderator before drafting a proposed Article and gathering the signatures to insert an Article on the Warrant
2. Petitioner will be listed as the sponsor of the Article on the Warrant and should be the first-named voter to sign this petition.
3. Selectmen will print the proposed Article in the Warrant verbatim; petitioner and citizens signing are advised to review the language carefully.
4. A word copy of this form is available by email from townclerk@wnewbury.org

Petitioner's Name: Richard Baker

Tel. #: 978-257-4101 E-mail: richard_a_baker_jr@yahoo.com

Address: 288 Middle Street, West Newbury

Proposed Title of Warrant Article: Conversion of the Mullen Property to Affordable Housing

Brief Summary: (purpose or reason for the proposed Article – not required but helpful)

In 2005, the Town purchased the Mullen property for affordable housing. The State is now pressuring towns via the MBTA initiative and other programs to increase housing stock in the Town. This motion intends to meet both the MBTA Housing initiative as well as needs for affordable housing in West Newbury with a single development on the Mullen property. Ideally, this program will significantly increase affordable housing in West Newbury under the 40R program and meet the MBTA Housing requirements.

Please complete this form and return it to the Town Clerk's Office. Attach the original forms with the required number of signatures* with the proposed Warrant Article at the top of each sheet. The signatures must be received no later than 3:30 PM the day the Board of Selectmen closes the Warrant.

Submit this document and the petition to the Town Clerk's Office

***ATM – 10 Certified Signatures Required**

***STM – 100 Certified Signatures Required**

(Use extra forms if number of signatures exceeds allotted lines)

Petition Articles will be printed in the Warrant verbatim; citizens should review the form and instructions carefully.

Petition by the Voters of the Town of West Newbury

DATE and TIME this paper received by Registrars

WEST NEWBURY CLERK
7/2/24

Warrant Article Submission for the 2024 Annual Town Meeting:

ARTICLE _____

To see if the Town will vote to transfer and/or appropriate from available funds the sum of \$100,000 to fund the costs associated with the creation of a district under MGL c. 40R for Town of West Newbury-owned lots identified on Assessors Maps as R13-131(the Mullen property), R13-130(the driveway for the Mullen property), and/or R10-34(the Soldiers and Sailors property) (the "Properties"); to prepare an Request for Proposals (the "RPP") for the disposal of all or any portion of the Properties, said work to satisfy the requirements of the MBTA Housing Requirements as described in Section 3A of MGL c. 40A and with the goal of maximizing the number of possible affordable housing units; and to authorize the Selectmen to dispose, by sale or lease, all or any portion of the Properties, subject to the RPP and other procurement requirements; or take any other action related thereto.

SIGNERS STATEMENT - We are qualified voters of the Commonwealth of Massachusetts and of the Town of West Newbury.

INSTRUCTIONS TO SIGNERS:

Your signature should be written as substantially as registered. If you are prevented, by physical disability, from writing you may authorize some person to write your name and residence in your presence.

	I	II	III	
	Check	Signatures to be made in person with name substantially as registered (except in case of physical disability as stated above)	Now Living At (Street and Number)	Printed Name
1	✓	[Signature]	288 Middle St	Richard Baker
2	✓	[Signature]	20 Bridge St.	William Studzinski
3	✓	[Signature]	20 Bridge	Dawn Studzinski
4	✓	[Signature]	288 Middle St.	Leisa Mingo
5	✓	[Signature]	125 Main St.	LORETTA HARRIS
6	✓	[Signature]	5 Archelaus Hill Rd	Catherine Dwan
7	✓	[Signature]	5 Archelaus Hill Rd.	David Baker
8	✓	[Signature]	16 Spring Hill Rd	CAROLYN GRIFONI
9	✓	[Signature]	16 Spring Hill Rd	Joseph Grifoni Jr
10				
11				
12				
13				
14				
15				
16				
17				
18				
19				
20				

Instructions to Registrars:

You must time-stamp or write in date and time these papers are received.

Check the name of qualified voter to be certified. For names not certified, use the codes opposite.

N- no such registered voter at that address. or address is illegible

S- unable to identify signature as that of voter because of form of signature, or signature is illegible

W- wrong community.

T- already signed this petition.

<p>CERTIFICATION OF SIGNATURES</p> <p>We certify that <u>(9) nine</u> <u>1/16/24</u> signatures checked are names of voters of the Town of West Newbury and are qualified to sign this petition.</p>	<p>(at least three registrars names must be signed or stamped below)</p> <p><i>Rosemond B. Veator</i> <i>Margaret [Signature]</i></p> <p>Board of Registrars of the Town of West Newbury</p> <p><i>Cheryl A. Grant</i></p>
---	--

Petition by the Voters of the Town of West Newbury

DATE and TIME this paper received by Registrars
 RECEIVED
 TOWN CLERK
 WEST NEWBURY, MA
 2024 JAN 18 PM 3:30

Warrant Article Submission for the 2024 Annual Town Meeting:

ARTICLE _____

To see if the Town will vote to transfer and/or appropriate from available funds the amount of \$100,000 for the costs associated with the creation of a district under MGL c. 40R for Town of West Newbury-owned lots identified on Assessors Maps as R13-131 (the Mullen property), R13-130 (the driveway for the Mullen property), and/or R10-34 (the Soldiers and Sailors property) (the "Properties"); to prepare an Request for Proposals (the "RFP") for the disposal of all or any portion of the Properties, said work to satisfy the requirements of the MBTA Housing Requirements as described in Section 3A of MGL c. 40A and with the goal of maximizing the number of possible affordable housing units; and to authorize the Selectmen to dispose, by sale or lease, all or any portion of the Properties, subject to the RFP and other procurement requirements; or take any other action related thereto.

SIGNERS STATEMENT - We are qualified voters of the Commonwealth of Massachusetts and of the Town of West Newbury.

INSTRUCTIONS TO SIGNERS:

Your signature should be written as substantially as registered. If you are prevented, by physical disability, from writing you may authorize some person to write your name and residence in your presence.

	I	II	III
Check	Signatures to be made in person with name substantially as registered (except in case of physical disability as stated above)	Now Living At (Street and Number)	Printed Name
1	✓ <i>Mark K. Powers</i>	211 Crane Neck St.	Mark K. Powers
2	✓ <i>Deborah L. Powers</i>	211 Crane Neck St.	Deborah L. Powers
3			
4			
5			
6			
7			
8			
9			
10			
11			
12			
13			
14			
15			
16			
17			
18			
19			
20			

Instructions to Registrars:

You must time-stamp or write in date and time these papers are received.

Check the name of qualified voter to be certified.
 For names not certified, use the codes opposite.

N- no such registered voter at that address. or address is illegible

S- unable to identify signature as that of voter because of form of signature, or signature is illegible

W- wrong community.

T- already signed this petition.

CERTIFICATION OF SIGNATURES

We certify that (2) Two 1/25/24
 signatures checked are names of voters of the Town of West Newbury and are qualified to sign this petition.

(at least three registrars names must be signed or stamped below)
Cheryl A. Grant
Rosamund A. Keator
Margaret St...
 Board of Registrars of the Town of West Newbury

Petition by the Voters of the Town of West Newbury

DATE and TIME this paper received by Registrars

REC'D W. NEWBURY, MASS.
24 JAN 16 PM 2:41

Warrant Article Submission for the 2024 Annual Town Meeting:

ARTICLE _____

To see if the Town will vote to transfer and/or appropriate from available funds the sum of \$100,000 to fund the costs associated with the creation of a district under MGL c. 40R for Town of West Newbury-owned lots identified on Assessors Maps as R13-131 (the Mullen property), R13-130 (the driveway for the Mullen property), and/or R10-34 (the Soldiers and Sailors property) (the "Properties"); to prepare an Request for Proposals (the "RFP") for the disposal of all or any portion of the Properties, said work to satisfy the requirements of the MBTA Housing Requirements as described in Section 3A of MGL c. 40A and with the goal of maximizing the number of possible affordable housing units; and to authorize the Selectmen to dispose, by sale or lease, all or any portion of the Properties, subject to the RFP and other procurement requirements; or take any other action related thereto.

SIGNERS STATEMENT - We are qualified voters of the Commonwealth of Massachusetts and of the Town of West Newbury.

INSTRUCTIONS TO SIGNERS:

Your signature should be written as substantially as registered. If you are prevented, by physical disability, from writing you may authorize some person to write your name and residence in your presence.

I

II

III

Check	Signatures to be made in person with name substantially as registered (except in case of physical disability as stated above)	Now Living At (Street and Number)	Printed Name
1	<i>Christine M. Cluney</i>	<i>12 Daley Dr.</i>	<i>CHRISTINE M. CLUNEY</i>
2	<i>John H. Cluney</i>	<i>12 DALEY DR</i>	<i>JOHN H. CLUNEY</i>
3			
4			
5			
6			
7			
8			
9			
10			
11			
12			
13			
14			
15			
16			
17			
18			
19			
20			

West Newbury

Cheryl A. Grant
1/16/24

Instructions to Registrars: (2) two 1/16/24

TOWN OF WEST NEWBURY
TOWN MEETING CITIZEN PETITION ARTICLE FORM

While not required, this form is the preferred method for a citizen to insert an Article on the Warrant for Town Meeting

IMPORTANT

1. Petitioner should consult with someone knowledgeable in municipal government, such as a lawyer, the Town Manager, or the Town Moderator before drafting a proposed Article and gathering the signatures to insert an Article on the Warrant
2. Petitioner will be listed as the sponsor of the Article on the Warrant and should be the first-named voter to sign this petition.
3. Selectmen will print the proposed Article in the Warrant verbatim; petitioner and citizens signing are advised to review the language carefully.
4. A word copy of this form is available by email from townclerk@wnewbury.org

Petitioner's Name: David Seaton

Tel. #: 978-363-8885 E-mail: david.jay.seaton@gmail.com

Address: 112 Crane Neck St. West Newbury Massachusetts

Proposed Title of Warrant Article: The West Newbury Empower Act

Brief Summary: (purpose or reason for the proposed Article – not required but helpful)

The West Newbury Empower Act is foremost, a measure to increase civic participation in town elections through increasing local election turnout, as a greater number of residents would be eligible to vote. By increasing the number of people participating in town elections, town elected officials will be able to be held accountable for the decisions that they make by young residents who will have to live for decades with the results of those town decisions. Finally, lowering the voting age in West Newbury would allow for 16 and 17 year olds to participate in our political system, just as they are given the right to participate in our transportation system through acquiring a driver's license, our economic system through working without restrictions on hours, our educational system by making the choice as to whether or not to drop out of school, and our governmental system through serving as an elections officer.

Please complete this form and return it to the Town Clerk's Office. Attach the original forms with the required number of signatures* with the proposed Warrant Article at the top of each sheet. The signatures must be received no later than 3:30 PM the day the Board of Selectmen closes the Warrant.

Petition by the Voters of the Town of West Newbury

DATE and TIME this paper received
by Registrars

2024 JAN 30 PM 4: 17

RECEIVED
TOWN CLERK
WEST NEWBURY, MA

Warrant Article Submission for the 2024 ____ Town Meeting:

ARTICLE _

To see if the Town will recommend to the Select Board that they file a home rule petition with the General Court substantially as follows, viz:

Notwithstanding Section 1 of Chapter 51 of the General Laws or any other general or special law to the contrary, any citizen who:

1. is 16 years of age or older, and
2. meets the qualifications to be registered as a voter pursuant to Section 1 of Chapter 51 of the General Laws, except that of age, and
3. is a resident of the town of West Newbury at the time he, she, or they registers or pre-registers to vote pursuant to said Chapter 51,

may vote therein in all town elections, participate and vote in all town meetings, participate and vote in town caucuses and sign all nominating, warrant, and other petitions authorized by town bylaws.

A person shall be a pre-registered or registered voter of at least sixteen (16) years of age to be eligible to serve in appointed town boards, committees, commissions, or other official positions.

SIGNERS STATEMENT - We are qualified voters of the Commonwealth of Massachusetts and of the Town of West Newbury.

INSTRUCTIONS TO SIGNERS:

Your signature should be written as substantially as registered. If you are prevented, by physical disability, from writing you may authorize some person to write your name and residence in your presence

	I	II	III
	C h e c k	Signatures to be made in person with name substantially as registered (except in case of physical disability as stated above)	Now Living At (Street and Number) Printed Name
1	✓	Dianna Fogel	4 Upland Lane Dianna Fogel
2	✓	James P. Speridakis	380 Middle St. JAMES P. SPERIDAKIS
3	✓	Richard Parker	153 Crane Neck St Richard Parker
4	✓	Debra C Green	1 Sullivan's Cir Debra C Green
5	✓	Barry Fogel	4 Upland Lane BARRY FOGEL
6	✓	Jeruska Ryan	23 Chestnut St JERUSKA RYAN
7	✓	Paul F. McCarthy	23 CHESTNUT ST. PAUL F. MCCARTHY
8	✓	Deborah B. Cronin-Vell	628 MAIN West Newbury DEBORAH B. CRONIN-VELL
9			
10			
11			
12			
13			
14			
15			
16			
17			
18			
19			
20			

Instructions to Registrars:

You must time-stamp or write in date and time these papers are received.

Check the name of qualified voter to be certified. For names not certified, use the codes opposite.

- N- no such registered voter at that address. or address is illegible
- S- unable to identify signature as that of voter because of form of signature, or signature is illegible
- W- wrong community.
- T- already signed this petition.

RECEIVED
 TOWN CLERK
 WEST NEWBURY, MA

<p>CERTIFICATION OF SIGNATURES</p> <p>We certify that <u>18 eight</u> _____) 1/30/24 _____ signatures checked are names of voters of the Town of West Newbury and are qualified to sign this petition.</p>	<p>(at least three registrars names must be signed or stamped below)</p> <p><i>Cheryl A. Grant</i> <i>Rosemond B. ...</i> <i>Margaret ...</i></p> <p>Board of Registrars of the Town of West Newbury</p>
--	--

2024 JAN 30 PM

	I	II	III	
	C h e c k	Signatures to be made in person with name substantially as registered (except in case of physical disability as stated above)	Now Living At (Street and Number)	Printed Name
1	✓	<i>David J. Seaton</i>	112 Crane Neck St.	David J. Seaton
2	✓	<i>Erin E. Seaton</i>	112 Crane Neck street	Erin E. Seaton
3	✓	<i>Stephen C Lorenz</i>	112 Crane Neck St	Stephen C Lorenz
4	✓	<i>David Belsky</i>	2 Barbory Ln	David Belsky
5	✓	<i>Paula Breger</i>	2 Barbory Ln	Paula Breger
6	✓	<i>Thomas L. Ellus</i>	74 Maple Street	Thomas L. Ellus
7	✓	<i>Patrick Bowe</i>	74 Maple Street	Patrick Bowe
8	✓	<i>Patricia Skirre</i>	396 Middle St.	PATRICIA SKIRRE
9	✓	<i>Lisa M. Forbush-Umlauf</i>	150 Middle St.	Lisa M. Forbush-Umlauf
10	✓	<i>Kurt Umlauf</i>	150 Middle St	Kurt Umlauf
11				
12				
13				
14				
15				
16				
17				
18				
19				
20				

Instructions to Registrars:

You must time-stamp or write in date and time these papers are received.

Check the name of qualified voter to be certified. For names not certified, use the codes opposite.

- N- no such registered voter at that address. or address is illegible
- S- unable to identify signature as that of voter because of form of signature, or signature is illegible
- W- wrong community.
- T- already signed this petition.

RECEIVED
 TOWN CLERK
 WEST NEWBURY, MA
 2024 JAN 30 PM 4:17

<p>CERTIFICATION OF SIGNATURES</p> <p>We certify that (10 ten) _____) 1/30/24 _____ signatures checked are names of voters of the Town of West Newbury and are qualified to sign this petition.</p>	<p>(at least three registrars names must be signed or stamped below)</p> <p><i>Cheryl A. Grant</i> <i>Rosemond B. Veater</i> <i>Margaret [Signature]</i></p> <p>Board of Registrars of the Town of West Newbury</p>
---	---

[Handwritten signatures and initials]